

INSTRUCTION MANUAL

Serial Number _____

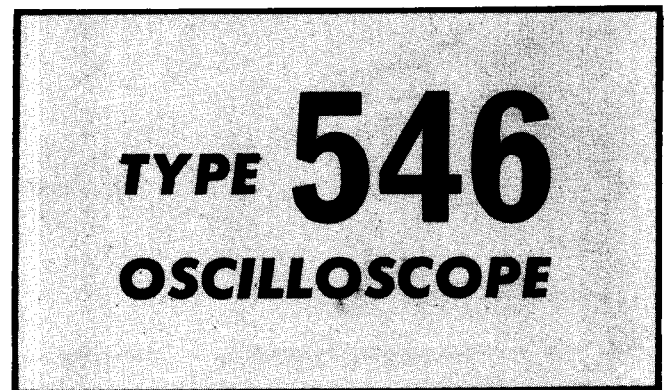

Tektronix, Inc.

S.W. Millikan Way ● P. O. Box 500 ● Beaverton, Oregon ● Phone MI 4-0161 ● Cables: Tektronix

Tektronix International A.G.

Terrassenweg 1A ● Zug, Switzerland ● PH. 042-49192 ● Cable: Tekintag, Zug Switzerland ● Telex 53.574

070-367

364

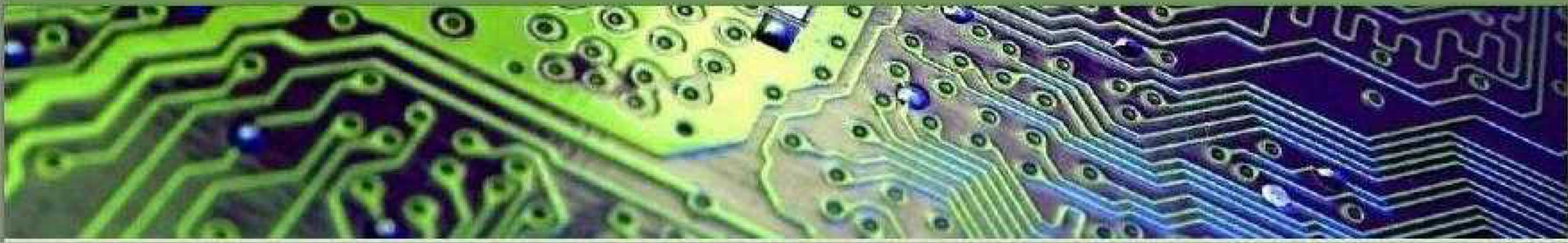

This manual is provided FREE OF CHARGE from EBAMAN.COM as a service to the technical community.

It was uploaded by someone who wanted to help you repair and maintain your equipment.

If you paid for this manual, you paid someone who is making a profit from the free labor of others without asking their permission.

**Thousands of files are available without charge from:
EBAMAN.COM**

Visit us at <http://ebaman.com>

**This file was provided by:
Jerry Ingordo W2JI**



WARRANTY

All Tektronix instruments are warranted against defective materials and workmanship for one year. Tektronix transformers, manufactured in our own plant, are warranted for the life of the instrument.

Any questions with respect to the warranty mentioned above should be taken up with your Tektronix Field Engineer.

Tektronix repair and replacement-part service is geared directly to the field, therefore all requests for repairs and replacement parts should be directed to the Tektronix Field Office or Representative in your area. This procedure will assure you the fastest possible service. Please include the instrument Type and Serial number with all requests for parts or service.

Specifications and price change privileges reserved.

Copyright © 1964 by Tektronix, Inc., Beaverton, Oregon. Printed in the United States of America. All rights reserved. Contents of this publication may not be reproduced in any form without permission of the copyright owner.



CONTENTS

Warranty

- | | |
|-----------|-------------------------|
| Section 1 | Characteristics |
| Section 2 | Operating Instructions |
| Section 3 | Circuit Description |
| Section 4 | Maintenance |
| Section 5 | Calibration |
| Section 6 | Parts List and Diagrams |

A list of abbreviations and symbols used in this manual will be found on page 6-1. Change information, if any, is located at the rear of the manual.

TYPE 546 OSCILLOSCOPE

SERIAL

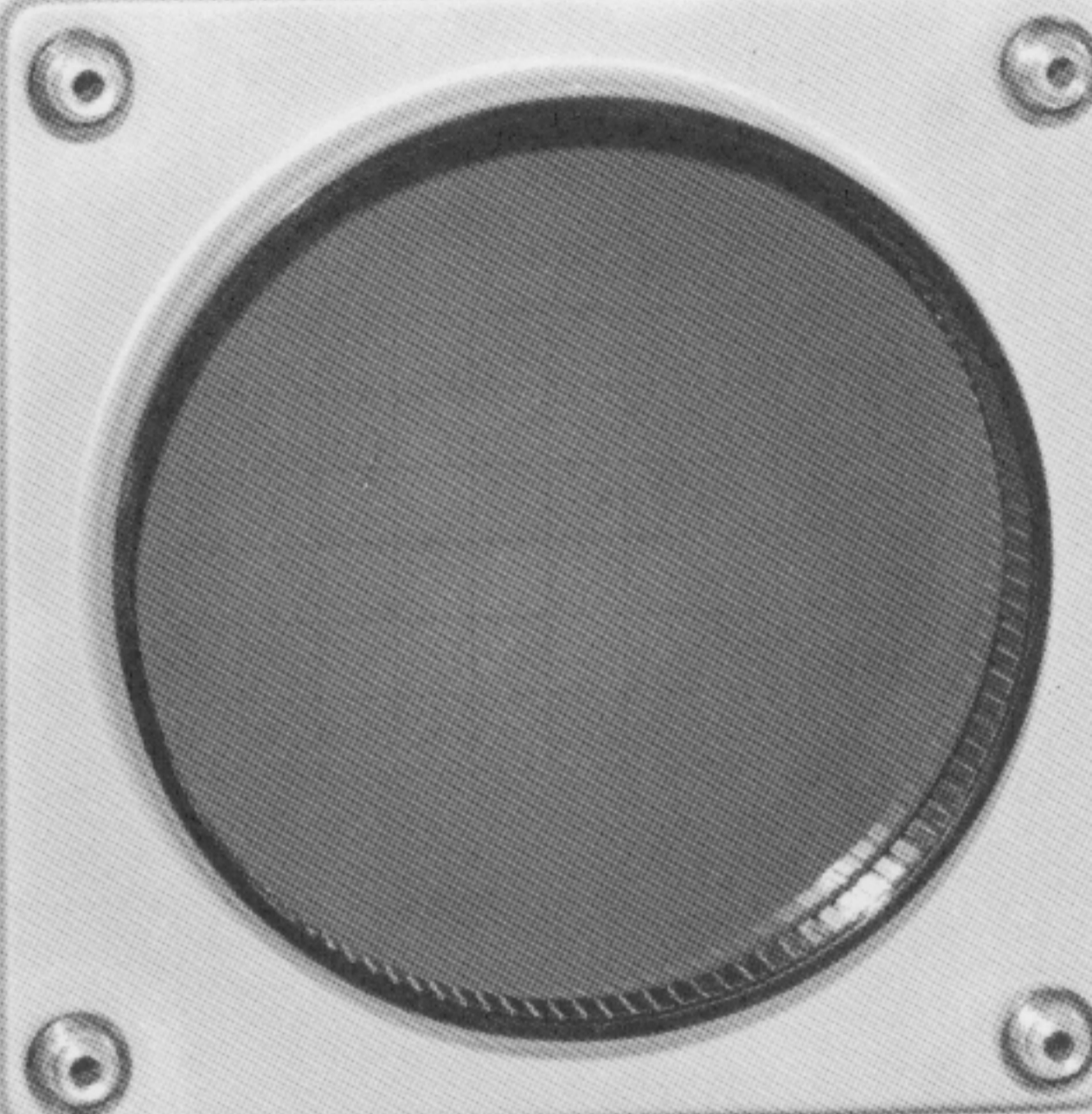

INTENSITY FOCUS TRACE ROTATION ASTIGMATISM SCALE ILLUM.

TIME BASE A

TRIGGERING LEVEL (0 to 10)

TRIGGERING: MODE (AUTO STABILITY, TRIG), SLOPE (+, -), COUPLING (AC, DC), SOURCE (NORM, INT, PLUG IN, LINE, EXT)

TRIGGER INPUT

PULL FOR X10 RANGE INCREASE

HORIZONTAL DISPLAY

MAG ON, READY, SINGLE SWEEP, RESET

VARIABLE TIME/CM (mSEC, SEC)

SWEEP MAGNIFIER (X1, X2, X10, X100)

INTENS BY 'A' (A, B)

VAR 10-1

HORIZ INPUT

MAIN TIME BASE (B)

TRIGGERING LEVEL (0 to 10)

TRIGGERING: MODE (AUTO STABILITY, TRIG), SLOPE (+, -), COUPLING (AC, DC), SOURCE (NORM, INT, PLUG IN, LINE, EXT)

TRIGGER INPUT

BRIGHTNESS

PULL FOR X10 RANGE INCREASE

VARIABLE TIME/CM OR DELAY TIME (mSEC, SEC)

DELAY-TIME MULTIPLIER 1-10

DLY'D TRIG

SWEEP A

AMPLITUDE CALIBRATOR

HORIZONTAL POSITION VERNIER

mVOLTS (1, 2, 5, 10, 20, 50, 100)

VOLTS (1, 2, 5, 10, 20, 50, 100)

5mA Ω CAL OUT

VERT SIG OUT

TYPE 1A1 DUAL-TRACE PLUG-IN UNIT

CHANNEL 1: POSITION, VARIABLE VOLTS/CM, .005 V/CM VAR ATTEN BAL, CH 1 SIGNAL OUT, CH 1 TRIGGER OUT, INPUT SELECTOR (AC, DC, GND)

CHANNEL 2: POSITION, VARIABLE VOLTS/CM, .005 V/CM VAR ATTEN BAL, CH 2 SIGNAL OUT, CH 2 TRIGGER OUT, INPUT SELECTOR (AC, DC, GND)

TEKTRONIX, INC. PORTLAND, OREGON, U.S.A.

TEKTRONIX, INC., PORTLAND, OREGON, U.S.A.

SECTION 1

CHARACTERISTICS

Introduction

The Type 546 Oscilloscope is a versatile laboratory instrument designed for use with all Tektronix letter-series plug-in units. The instrument features two identical time-base generators. The two time-base generators can be used singly or in "delaying" and "delayed" sweep operation for highly accurate time-differential measurements.

Vertical Deflection System

The plug-in unit and probe used with the Type 546 determine the overall characteristics of the vertical deflection system. Refer to Table 1-1 for the characteristics.

Sweep Generation

Trigger features and sweep rates of both Type 546 time-base circuits are identical.

Sweep Rates (at 1X magnification) 0.1 μ second/cm to 5 seconds/cm in 24 calibrated steps. Displayed sweep-rate accuracy is $\pm 2\%$ for both sweeps. An uncalibrated variable control of sweep rate permits either sweep to be slowed to no more than 40% of the indicated rate.

Sweep Magnification Any sweep rate can be increased by horizontal expansion of the center portion of

the display in fixed steps of 2X, 5X, and 10X. Sweep-rate accuracy is within 5%.

Trigger Source Selection Internal, internal plug-in, external and line.

Trigger Coupling Selection Dc, ac and ac low-frequency rejection.

Trigger Signal Internal (ac): Minimum deflection is 2 mm, rising to 1 cm at about 50 mc.

Requirements Internal (dc): Minimum deflection is 5 mm.

Internal (ac low-frequency rejection): Minimum deflection is 2 mm with signals at about 2 kc, rising to 1 cm at about 50 mc.

External: Frequency ranges are the same as internal. Minimum amplitude is: 200 mvolts, peak-to-peak, (ac), 200 mvolts, change in dc level (dc) and, 200 mvolts peak-to-peak (ac low-frequency reject). Maximum trigger level range is greater than ± 2 volts with the TRIGGERING LEVEL control pushed in and ± 20 volts with the control pulled out.

TABLE 1-1
PLUG-IN CHARACTERISTICS FOR THE
TYPE 546 OSCILLOSCOPE

PLUG-IN UNIT	CALIBRATED DEFLECTION FACTOR	BANDPASS	RISETIME	INPUT CAPACITANCE
Type 1A1**	50 mv/cm to 20 v/cm 5 mv/cm	dc to 50 mc dc to 28 mc	7 nsec 12.5 nsec	15 pf
Type B	5 mv/cm to 0.02 v/cm 0.05 v/cm to 20 v/cm	2 cps to 12 mc dc to 20 mc	30 nsec 18 nsec	47 pf
Type CA**	0.05 v/cm to 20 v/cm	dc to 24 mc	15 nsec	47 pf
Type D	1mv/cm to 50 v/cm	dc to 300 kc-2 mc	0.18 μ sec	47 pf
Type E	50 μ v/cm to 10 mv/cm	0.06 cps to 20 kc-60 kc	6 μ sec	50 pf
Type G	0.05 v/cm to 20 v/cm	dc to 20 mc	18 nsec	47 pf
Type H	5 mv/cm to 20 v/cm	dc to 15 mc	23 nsec	47 pf
Type K	0.05 v/cm to 20 v/cm	dc to 30 mc	12 nsec	47 pf
Type L	5 mv/cm to 2 v/cm 0.05 v/cm to 20 v/cm	3 cps to 24 mc dc to 30 mc	15 nsec 12 nsec	20 pf
Type M**	0.02 v/cm to 10 v/cm	dc to 20 mc	17 nsec	47 pf
Type N*	10 mv/cm	dc to 600 mc	0.6 nsec	50 Ω Input Z
Type O*	0.05 v/cm to 20 v/cm	dc to 25 mc	14 nsec	47 pf
Type Q*	10 μ strain/cm to 10,000 μ strain/cm	dc to 6 kc	60 μ sec	Adjustable
Type R*	0.5 ma/cm to 100 ma/cm			
Type S*	0.05 v/cm and 0.5 v/cm			
Type T	Time-Base Generator Plug-In Unit			
Type Z*	0.05 v/cm to 25 v/cm	dc to 13 mc	27 nsec	24 pf

*Special feature plug-in units—see your Tektronix catalog for more information on any of the plug-in units.
**Multiple-trace plug-in units.

Characteristics — Type 546/RM546

Sweep Delay The Time-Base A sweep can be delayed by the Main Time Base (B) sweep. Delay is continuously variable over the range of 0.1 μ sec to 50 sec with the DELAY TIME and DELAY-TIME MULTIPLIER controls. Delay time is accurate to $\pm 1\%$ of indicated delay ± 2 minor divisions of the DELAY-TIME MULTIPLIER at sweep rates from 50 μ sec to 50 sec. At delay times shorter than 50 μ sec, indicated delay accuracy is the same as above plus approximately 75-100 nsec. The 75-100 nsec represents the fixed inherent delay of the internal trigger circuitry of the Type 546. Incremental delay accuracy is ± 2 minor divisions of the DELAY-TIME MULTIPLIER dial at sweep rates from 1 μ sec to 50 sec. Incremental accuracy at the three fastest sweep rates (.1, .2, and .5 μ sec) is ± 5 minor divisions. Stated accuracies apply only when the VARIABLE controls are set to CALIB. Delay jitter is no greater than 1 part in 20,000.

Horizontal Deflection System

The following characteristics apply when the HORIZONTAL DISPLAY switch is set to the EXT positions.

Deflection Factor 0.1 volt/cm to 20 volt/cm; continuously adjustable.

Frequency Response Dc to 400 kc (3-db down frequency).

Input Characteristics 1 megohm paralleled by approximately 55 pf.

Amplitude Calibrator

Output Voltages 0.2 millivolts to 100 volts, peak-to-peak, in 18 steps. In addition, a 100-volt dc output is available.

Frequency Approximately 1-kc square wave.

Risetime .2 mv-5 volts; .5 μ sec or faster. 10-100 volts; 1 μ sec or faster.

Output Current 5 milliamperes, 1-kc square wave available at the front-panel current loop.

Output Impedance 50 Ω in 0.2 to 200-millivolt positions. Progressively higher output impedances in the .5- to 50-volt positions up to about 4 k Ω in the 50-volt position. Output impedance of the 100-volt positions (ac and dc) is about 420 Ω .

Amplitude Accuracy Peak-to-peak amplitude accuracy is within $\pm 3\%$ of indicated when working into an impedance of 1 megohm or higher in the .5 to 100 volt positions. When working into a 50-ohm load, in the .2 to 200 mvolt positions, output amplitude is one-half of the indicated voltage. Nominal accuracy, in this case, is $\pm 3\%$ —assuming the external load impedance is an accurate 50 ohms. Accuracy of the current in the current loop is $\pm 3\%$.

Front-Panel Output Signals

+GATE B Approximately a 20-volt, peak-to-peak, square-wave pulse having the same duration as the B sweep. Minimum load impedance is 5 k Ω .

DLY'D TRIG Approximately a 10-volt peak-to-peak pulse with a maximum duration of .5 μ sec occurring at the end of the delay period.

SWEEP A Approximately a 100-volt, peak-to-peak sawtooth voltage having the same duration as the A sweep. Minimum load impedance is 100 k Ω .

+GATE A Approximately a 20-volt, peak-to-peak, square-wave pulse having the same duration as the A sweep. Minimum load impedance is 5 k Ω .

VERT SIG OUT Vertical signal output connector. Output amplitude is approximately 0.4 volts per centimeter of deflection on the crt. Rise-time is 20 nsec or faster. Output is ac coupled.

External Single-Sweep Reset Input-Signal Requirements Requires a positive going step or pulse of at least +20 volts with a risetime of 0.5 μ sec or faster.

Cathode Ray Tube

Type T5470-31-2

Unblanking Dc coupled

Accelerating Potential 10 kv

Deflection System Electrostatic

Useable Viewing Area 6 cm high by 10 cm wide

Construction All glass, 5-inch, flat faced crt

Graticule Internal; adjustable edge lighting. 6 x 10 cm; with vertical and horizontal 1-centimeter divisions with 2-millimeter markings on the center-lines. Provision made for risetime measurement.

Power Supplies

Line Voltage 115 volts $\pm 10\%$ or 230 volts $\pm 10\%$

Line Frequency 50-60 and 400 cps*.

Power Consumption About 510 watts

Overload Protection Primary of power transformer is fused and a thermal relay is installed that interrupts power in the event of over-heating.

*With line frequencies of 400 cps, a special fan modification is required; contact your local Tektronix Field representative.

Cabinet and Chassis Construction

Cabinet Three piece, blue vinyl covered, textured aluminum. Front panel is photo etched and anodized. Cabinet dimensions are 13" (w) x 24" (l) x 16³/₄" (h).

Chassis Aluminum alloy.
Net weight 65³/₄ pounds.

SECTION 2

OPERATING INSTRUCTIONS

FUNCTION OF EXTERNAL CONTROLS AND CONNECTORS

Time Base A Controls

TRIGGERING LEVEL	Selects the amplitude point on the triggering signal where sweep triggering occurs. When the knob is pulled out, greater triggering range is offered for triggering on higher amplitude trigger signals. With ac coupling, the triggering circuit is most sensitive with the TRIGGERING LEVEL control pushed in and set at 0.
TRIGGERING MODE	AUTO STABILITY permits normal triggering on signals with repetition rates higher than about 20 cps. With no trigger signal, or with a lower repetition rate, the time base circuit free runs and provides a handy reference trace. TRIG (triggered) permits normal triggering on all triggering signals. No trace occurs when the triggering signal is removed.
SLOPE	Determines whether the time base is triggered on the negative-(—) or positive-(+) going slope of the signal.
COUPLING	AC position blocks any dc component of the triggering signal and allows triggering to take place only on the changing portion of the signal. With frequencies below about 30 cps, use the DC position. AC LF REJ position rejects trigger signal frequencies below about 1.5 kc allowing the trigger circuits to respond to higher frequencies. DC position permits triggering on both high- and low- (to dc) frequency signals.
SOURCE	NORM position uses a version of the signal applied to the vertical deflection plates of the crt as a trigger signal. PLUG IN position applies to the Tektronix Type 1A1 or a modified Type CA plug-in unit when it is desired to trigger only on the Channel 1 signal. LINE position uses the line frequency signal as a trigger. EXT position is for external triggering on a signal applied to the TRIGGER INPUT connector.
TIME/CM VARIABLE	Selects the sweep rate of Time Base A. Provides an uncalibrated adjustment of sweep rate. The sweep rate can be slowed by a factor of at least 2.5X. An UNCALIBRATED lamp lights to warn when the VARIABLE control is not in the CALIBRATED position.

Main Time Base (B) Controls

All controls of the Main Time Base (B) serve the same function as the Time Base A controls with the exception of the following additional control.

BRIGHTNESS	Allows adjustment of the contrast or brightness ratio of the B trace compared to the A trace.
HORIZONTAL DISPLAY	The A position allows only Time Base A to display on the crt. The B position allows only the Main Time Base (B) to display on the crt. B INTENS BY 'A' is one of the delayed sweep functions. In this position, a portion of the Main Time Base (B) is intensified during the time that Time Base A (the delayed sweep) is in operation. A DLY'D is one of the delayed sweep functions. In this position Time Base A is displayed at the end of each delay period as determined by the B TIME/CM OR DELAY TIME and DELAY-TIME MULTIPLIER controls. EXT X1 and X10 positions permit an external signal to be applied to the horizontal deflection circuit. Sensitivity is continuously variable (with the VAR 10-1 control).
READY LAMPS	These light when the corresponding time-base circuit is ready for triggering.
SWEEP MAGNIFIER	Expands the sweep from the center of the graticule at any given setting of the TIME/CM switch by the amount indicated.
SINGLE SWEEP	Permits single sweep operation in all modes of horizontal display except EXT.
DELAY-TIME MULTIPLIER 1-10	Works in conjunction with the TIME/CM OR DELAY TIME control of the Main Time Base (B). Varies delay from 0.10X to 10.10X the time indicated by the Main Time Base (B) TIME/CM OR DELAY TIME switch.
HORIZONTAL POSITION VERNIER	Positions the display along the horizontal axis of the crt.
AMPLITUDE CALIBRATOR	Determines the peak-to-peak voltage at the CAL OUT connector.
5 mA Current Strap	Provides a calibrated source of square-wave current. The arrow shows direction of conventional current flow (i.e. positive to negative).
POWER SWITCH	Toggle switch for turning the instrument on and off.
INTENSITY	Controls brightness of the display.
FOCUS	Used in conjunction with the INTENSITY and ASTIGMATISM controls for obtaining a well-defined display.

Operating Instructions — Type 546/RM546

ASTIGMATISM	Used in conjunction with the INTENSITY and FOCUS controls for obtaining a well-defined display.
TRACE ROTATION	Permits horizontal alignment of the trace with respect to the horizontal lines of the graticule.
SCALE ILLUM	Varies illumination of the grid lines on the internal graticule.
Beam Position Indicators	Four neon lamps with accompanying arrows indicate the direction when the display is deflected out of the viewing area.
TRIGGER INPUT (Time Base A)	Connector for applying an external trigger signal to Time Base A when its SOURCE switch is set to EXT.
HORIZ INPUT	Jack for applying external horizontal signal when the HORIZONTAL DISPLAY switch is set to either X1 or X10 EXT.
TRIGGER INPUT (Main Time Base (B))	Connector for applying an external trigger signal to the Main Time Base (B) when its SOURCE switch is set to EXT.
+GATE B	Supplies a 20-30-volt square-wave pulse when the Main Time Base (B) is operating. Pulse duration is approximately 10.5X the setting of the TIME/CM OR DELAY TIME switch when the VARIABLE control is set to CALIBRATED.
DLY'D TRIG	Supplies a sharp positive-going trigger spike of about 10 volts at the end of the delay period as set by the TIME/CM OR DELAY TIME switch and the DELAY-TIME MULTIPLIER control.
SWEEP A	Supplies the sawtooth voltage of TIME BASE A. Peak amplitude is about +100 volts.
+GATE A	Same as +GATE B except applies to Time Base A.
VERT SIG OUT	Vertical signal output connector. Output amplitude is approximately 0.4 volt per centimeter of deflection.
Chopped Blanking Switch (rear panel)	Provides blanking of between-channel switching transients when using multi-channel plug-in units in the chopped mode.
External Single Sweep Reset	Allows remote control of resetting in single-sweep operation. The sweep resets by the momentary application of +20 volts or more.
EXTERNAL DELAY INPUT (rear panel)	A four-pin connector is provided for an external delay generator (rather than the normal internal delay produced by the B sweep). Pin A of the connector permits disabling of the normal internal delayed trigger and is the feed-in point for the external delay trigger (see Fig. 2-1). Pin B is normally dc open and ac ground (through a 0.01 μ f capacitor). Pin C supplies a B-gate pulse. Pulse characteristics are: +2 volts peak with a risetime of 50

nsec or faster into a load of 1 k paralleled by 100 pf. Duration of the pulse is the same as the length of the B sweep. Pin D is ground at all times.

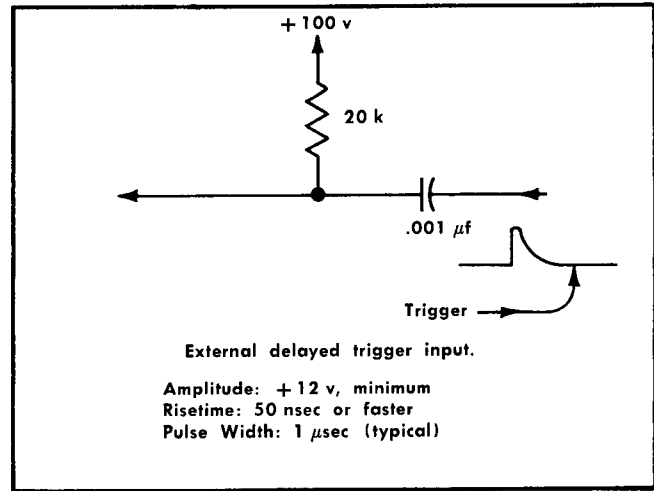

Fig. 2-1. Method of coupling an external delayed trigger into the Type 546.

NORMAL (NON-DELAYED) SWEEP OPERATION

Sweep Triggering

Proper sweep triggering is essential for a stable presentation of an input signal. For a stable display, the sweep must be triggered at the same time relative to the displayed signal. Thus, the sweep must be triggered by the displayed signal or by some external signal that has a fixed time relationship with the displayed signal. The external trigger signal must be the same frequency or a lower frequency multiple of the input signal.

Selecting the Trigger Source

The SOURCE switches select one of a variety of possible triggering signals. For most applications, the sweep can be triggered internally from the displayed signal. This occurs with the SOURCE switch set at NORM.

The PLUG IN position is for plug-in units that will supply a single-channel triggering signal through pin 5 of the interconnecting plug such as the Tektronix Type 1A1 Dual-Trace Plug-In Unit. This position is useful when operating the plug-in unit in the dual-trace chopped-mode of operation since the triggering signal is the same as the applied signal and is free from any between-channel switching transients.

The LINE position of the SOURCE switch connects a line-frequency signal to the triggering network. Line triggering is useful whenever the input signal is related in frequency to the line frequency.

To trigger the time base from an external signal, set the SOURCE switch to EXT and connect the external trigger signal to the TRIGGER INPUT connector. External triggering is often used when signal tracing in amplifiers, phase-shift networks, and wave-shaping circuits. The signal from a single

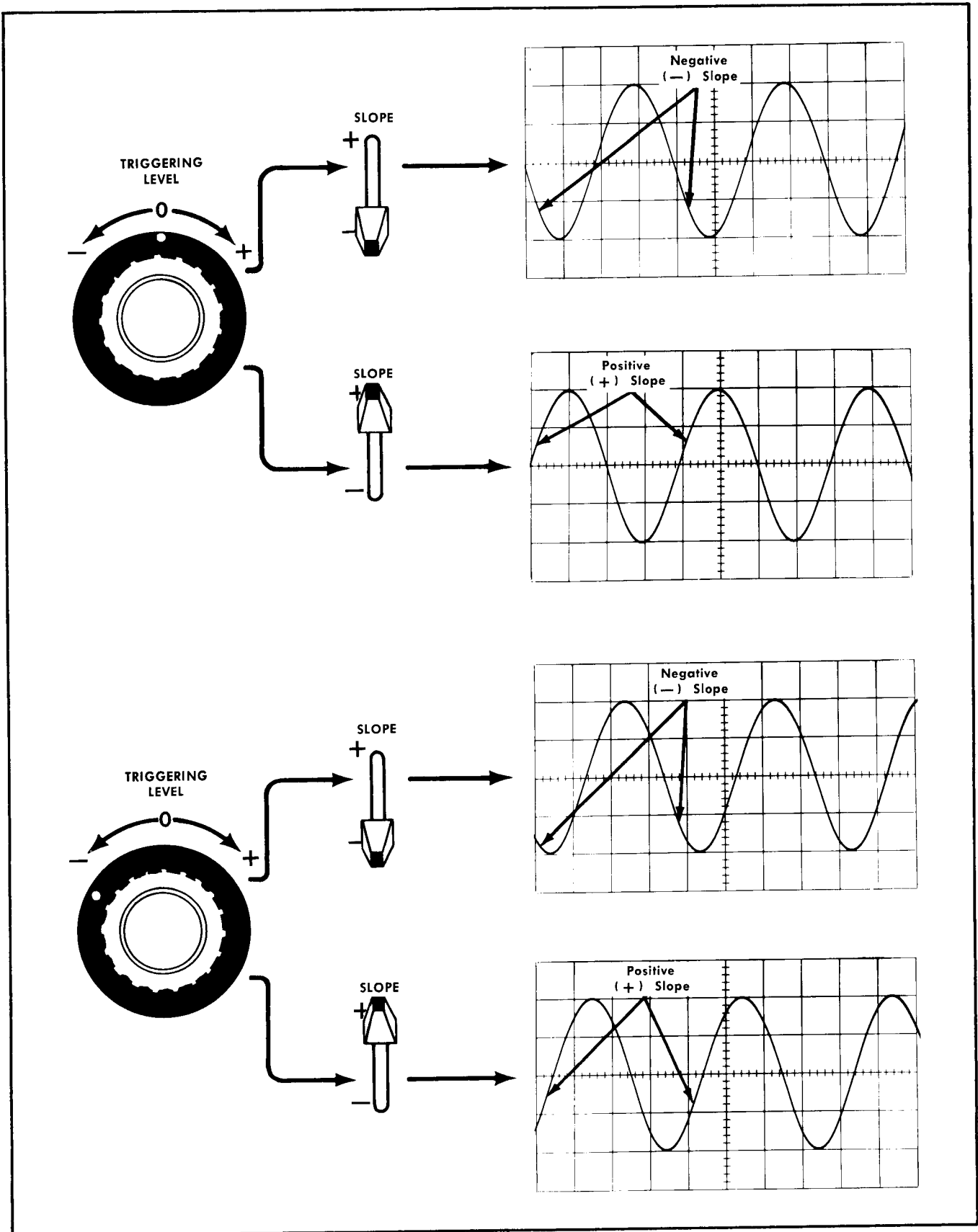

Fig. 2-2. Effects of the TRIGGERING LEVEL and SLOPE controls.

point in the circuit can be used as the external trigger signal. With this arrangement, it is possible to observe the shaping and/or amplification of a signal at various points through the circuit without resetting the triggering controls for each new display.

Selecting the Trigger Coupling

Three means of trigger coupling are available with the COUPLING switches. The different coupling positions permit you to accept or reject certain frequency components of the triggering signal.

With the COUPLING switch set at DC, the time base can be triggered with all frequency components of the triggering signal including dc levels.

With the COUPLING switch set at AC, the dc component of the triggering signal is blocked. Also, low-frequency signals below about 30 cps are attenuated.

With the COUPLING switch set at AC LF REJ, dc and low-frequency signals (below about 1.5 kc) are rejected or attenuated. Using AC LF REJ, the trigger circuit responds best to the higher frequency components of the triggering signal.

In general, use AC coupling. However, it will be necessary to use DC coupling for very low-frequency signals. When line frequency hum is mixed with the triggering signal, it is best to use AC LF REJ coupling so that triggering takes place only on the signal of interest (if the signal of interest contains frequency components above about 1.5 kc).

The AC LF REJ coupling position is also useful when triggering internally from multi-trace plug-in units operated in the alternate mode of dual trace (unless the plug-in unit is a Type 1A1 and the SOURCE switch is set to PLUG IN). AC LF REJ coupling has a faster recovery time when subjected to the alternate dc levels from the multi-trace plug-in unit.

Selecting the Trigger Slope

The trigger SLOPE switch determines whether triggering occurs on the rising (+ setting) or the falling (— setting) portion of the triggering signal. When several cycles of a signal appear in the display, the setting of the SLOPE switch will probably be unimportant. However, if you wish to look at only a certain portion of a cycle, the SLOPE switch will help you to start the display on the desired slope of the input signal. Fig. 2-2 illustrates the effect of both the SLOPE and TRIGGERING LEVEL controls.

Selecting the Trigger Mode

The AUTO STABILITY mode is generally more convenient. With the MODE switch set to AUTO STABILITY, proper triggering takes place after setting the TRIGGERING LEVEL control. When the triggering signal is removed, the time base circuit automatically free runs and presents a reference display.

The TRIG position of the MODE switch should be used if the repetition rate of the trigger signal has a very low repetition rate (below about 20 cps).

Setting the Triggering Level

The TRIGGERING LEVEL control determines the amplitude point on the signal where triggering occurs.

The trigger circuit is most sensitive to ac triggering signals with the TRIGGERING LEVEL control set near zero and pushed in. Moving the TRIGGERING LEVEL control in the + direction causes the trigger circuit to respond at some higher positive amplitude on the triggering signal. Moving the TRIGGERING LEVEL control in the — direction causes the trigger circuit to respond at some higher negative amplitude on the triggering signal. Fig. 2-2 illustrates the effect of the TRIGGERING LEVEL control and the SLOPE switch.

The range of the TRIGGERING LEVEL control is extended 10 times when it is pulled out. This permits more satisfactory triggering on larger amplitude trigger signals.

Selecting the Time/CM (Sweep Rate)

The TIME/CM and SWEEP MAGNIFIER switches control sweep rate of the display. The SWEEP MAGNIFIER expands the displays of both time bases.

The TIME/CM and SWEEP MAGNIFIER allow you to view an applied signal at a wide variety of calibrated sweep rates. When you make time measurements from the crt, be sure the VARIABLE control is set to CALIBRATED.

When the SWEEP MAGNIFIER is set to X1, the TIME/CM switch indicates the displayed sweep rate. With SWEEP MAGNIFIER set to X2 (for example), divide the setting of the TIME/CM switch by 2 to determine the true sweep rate. For example, assume that the TIME/CM switch is set to 1 mSEC per division and the SWEEP MAGNIFIER is set to X5. In this case, the true sweep rate would be 1 (msec) divided by 5 (SWEEP MAGNIFIER setting); giving a displayed sweep rate of .2 milliseconds per division. Fig. 2-3 illustrates how to make time measurements from the graticule.

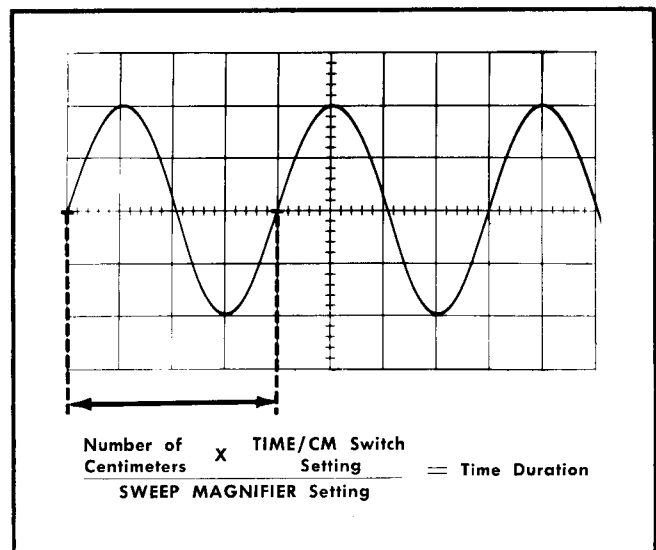

Fig. 2-3. Illustration of time measurement from the graticule.

Single Sweep Operation

In applications where the displayed signal is not repetitive or varies in amplitude, shape, or time, a conventional repetitive display may produce a jumbled display. To avoid this, use the single sweep feature of the Type 546 oscilloscope.

To use single sweep, first make sure the trigger circuit will trigger on the event you will wish to display. Do this in the conventional manner with the SINGLE SWEEP switch set at NORMAL.

Depress the SINGLE SWEEP to the RESET position and release the switch so it returns to the SINGLE SWEEP position. When this is completed, the next trigger pulse will actuate the sweep and the instrument will display the event on a single trace. The READY lamps, near the HORIZONTAL DISPLAY switch, first light when the sweep is ready to accept a trigger and then go out after triggering has taken place. To ready the circuit for another single display, depress the SINGLE SWEEP switch to RESET and release. In single sweep operation, make sure the MODE switch is set to TRIG.

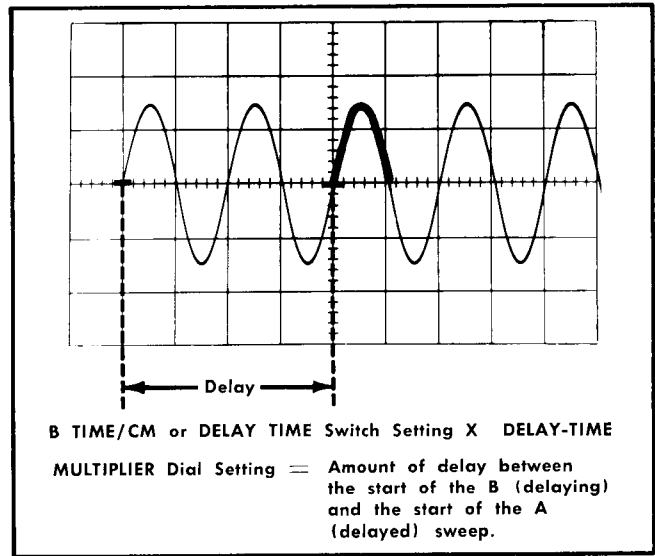

Fig. 2-4. Determining delay time.

NON-TRIGGERED DELAYED SWEEP

Introduction

The following describes various measurements and other operations that can be performed using delayed sweep; the accuracy of those measurements; and the operating procedures involved.

Insert a vertical plug-in unit and set the controls and switches on the instruments as listed in Table 2-1.

Set HORIZONTAL POSITION so the trace begins precisely at the left-hand edge of the graticule. Notice the position of the intensified segment in the trace.

Now set the B TIME/CM OR DELAY TIME switch to .2 SEC and A TIME/CM to 20 mSEC. The intensified segment should be at the same position as with the previous sweep rates.

Connect the SWEEP A output to the vertical plug-in unit input. Notice that the A sweep sawtooth and the intensified segment in the trace start and end at the same time. This display shows that TIME BASE A produces one sweep during the intensified segment of each B sweep. The A TRIGGERING LEVEL control has no effect.

The B sweep rate is .2 second per centimeter. The intensified segment begins 5 centimeters after the beginning of the trace. Hence, the A sweep starts one second after the B sweep (0.2 second per centimeter times 5 centimeters).

The number of centimeters between the beginning of the trace and the beginning of the intensified segment is established by the setting of the DELAY-TIME MULTIPLIER control. Therefore, with any dial setting, the time difference between the beginning of the A and B sweeps is the product of the B TIME/CM OR DELAY TIME and the DELAY-TIME MULTIPLIER dial setting (see Fig. 2-4).

TABLE 2-1

B MODE	AUTO STABILITY
B SOURCE	NORM
B COUPLING	AC
B SLOPE	+
B TRIGGERING LEVEL	0
B TIME/CM OR DELAY TIME	1 mSEC
A MODE	AUTO STABILITY
A SOURCE	EXT
A TIME/CM	.1 mSEC
VARIABLE (A and B)	CALIBRATED
HORIZONTAL DISPLAY	B INTENS BY 'A'
SWEEP MAGNIFIER	OFF (X1)
DELAY-TIME MULTIPLIER	5.00
AMPLITUDE CALIBRATOR	10 Volts
HORIZONTAL POSITION	Centered
INTENSITY	So both intensity levels in the trace are easily seen.

Set the applicable controls and switches of the vertical plug-in unit as follows:

VOLTS/DIV	5
VARIABLE	CALIBRATED
AC-DC-GND	DC
POSITION	Trace Centered

The following procedures show five common applications of the delayed sweep feature. These applications are more accurate than the time measurements that are taken directly from the crt display.

Demonstration 1

Measurement of pulse duration with the pulse triggering the Main Time Base (B).

Operating Instructions — Type 546/RM546

Set the controls and switches on the instrument as listed in Table 2-1 except as follows:

B TIME/CM OR DELAY TIME	.1 mSEC
A TIME/CM	1 μ SEC

Apply the AMPLITUDE CALIBRATOR signal to the input of the vertical plug-in unit. If necessary, adjust B TRIGGERING LEVEL to obtain a stable display. The display should consist of nearly one cycle of the square-wave signal.

Set the DELAY-TIME MULTIPLIER dial to intensify the falling portion of the square wave. Set the HORIZONTAL DISPLAY switch to A DLY'D. The display should now be a horizontally expanded version of the signal observed in the intensified segment of the previous display. Adjust the BRIGHTNESS control of the Main Time Base (B) to equalize the intensity.

Set DELAY-TIME MULTIPLIER so the falling 50% point on the delayed trace exactly crosses the point where the 50% amplitude level on the rising portion of the intensified display appeared (this point may be hard to see but will be very near the start of the trace). Multiply the DELAY-TIME MULTIPLIER dial reading (e.g. 5.03) by the B TIME/CM OR DELAY TIME setting. The product is the time duration of the square wave positive-going half-cycle.

Accuracy: Accuracy is determined by the combination of all the following factors:

1. The basic accuracy of time measurements made by using sweep delay is as stated in Section 1 of this manual.

2. The DELAY PICKOFF and Time Base A generator circuits typically require a net total of about 75 to 100 nanoseconds to respond to the signal event which triggers the Delayed Sweep (A). This small inherent delay need not be considered unless it is a significant percentage (delay times shorter than 50 μ sec) of the measured time or when measuring time differences when using the same sweep delay range. When necessary, add the net circuit delay time to the measured time: that is, when measuring the time from the start of the B sweep.

Summary: The method described in Demonstration 1 provides a time measurement accuracy within 1% of reading ± 2 minor division of the DELAY-TIME MULTIPLIER dial.

By comparing the delay reading to an accurate external timing standard (such as a Tektronix 180A Time Mark Generator) and applying a correction factor, an accuracy of ± 2 minor divisions of the DELAY-TIME MULTIPLIER dial can be achieved.

Demonstration 2

Measuring time between two pulses, neither of which triggers Time Base A.

Set the controls and switches on the instrument as listed in Table 2-1 except as follows:

B TIME/CM OR DELAY TIME	.2 mSEC
A TIME/CM	2 μ SEC

Apply the AMPLITUDE CALIBRATOR signal to the vertical input. If necessary, adjust the 'B' TRIGGERING LEVEL to

obtain a stable display. The display should consist of about two cycles of the square wave. Set the DELAY-TIME MULTIPLIER so the square wave rise located near the center of the display is intensified.

Set the HORIZONTAL DISPLAY to the A DLY'D position. The display should now be a horizontally expanded version of the intensified segment.

Set DELAY-TIME MULTIPLIER so the rising 50% amplitude level of the square wave intersects the vertical centerline of the graticule. Note the exact setting of the DELAY-TIME MULTIPLIER (e.g. 5.48). Turn the DELAY-TIME MULTIPLIER clockwise until the falling 50% amplitude level of the square wave intersects the same vertical graticule centerline used with the previous dial setting. Again note the exact setting of DELAY-TIME MULTIPLIER dial.

Subtract the first dial setting from the second. The product of the difference times the B TIME/CM OR DELAY TIME equals the time duration of the square-wave positive-going half-cycle (between the 50% amplitude points). This measurement should indicate a time of about 0.5 millisecond.

Accuracy: Accuracy is determined by the combination of the following factors:

1. The basic accuracy of the sweep delay, as described in Demonstration 1.

2. The error added by the sweep-delay system linearity is ± 2 minor dial divisions of the DELAY-TIME MULTIPLIER dial. Hence, per cent error of measurement decreases as the numerical dial difference increases.

NOTE

When the separation between dial settings is 100 minor dial divisions or less, the time measurement can often be made more accurate by direct reading from a magnified crt display. See Demonstration 3; Magnification.

3. The accuracy of time measurements made in Demonstration 2 is independent of the inherent circuit delays providing the B TRIGGERING LEVEL control setting is the same for each of the two dial readings.

Summary: The method described in Demonstration 2, provides time measurement accuracy as stated in Section 1. Accuracy will be greatest when the numerical dial difference between the two DELAY-TIME MULTIPLIER readings is greatest.

Demonstration 3

Complex signals contain a number of individual events of different amplitudes. Since the trigger circuits of the Type 546 respond to signal amplitude, a stable display will normally be obtained only when the sweep is triggered by the event having the greatest amplitude. The A DLY'D mode permits the start of the A sweep to be delayed for a selected time after the signal event having the greatest amplitude. Any event within the series of events may then be displayed in magnified form as follows:

Set the controls and switches on the instrument as listed in Table 2-1. Apply the AMPLITUDE CALIBRATOR signal to the vertical input. If necessary, adjust B TRIGGERING LEVEL to obtain a stable display. The display should consist of several cycles of the square wave signal. Set DELAY-TIME MULTIPLIER to intensify one of the positive-going pulses.

Set the HORIZONTAL DISPLAY switch to A DLY'D. The display should now be the same signal information as the intensified trace segment, but horizontally expanded (magnified) ten times.

Increase the A sweep rate to 1 microsecond per division. Set DELAY-TIME MULTIPLIER to position a square wave rise on the crt. The display now gives X1000 magnification of the intensified segment.

Slowly turn the DELAY-TIME MULTIPLIER dial. Note that any portion of the square wave can be brought into view in magnified form.

The DELAY-TIME MULTIPLIER reading corresponds to the number of centimeters between the beginning of the time base B trace and the beginning of the time base A (intensified) trace: e.g. 7.00=7 major divisions.

The A DLY'D display will probably exhibit some horizontal jitter. The time jitter contributed by the delay system is less than 5×10^{-5} times the B TIME/CM OR DELAY TIME setting. Since the sweep rate of the delayed sweep is now 1 microsecond per centimeter, the jitter due to the delay system is less than one-half centimeter.

Accuracy: The accuracy of time measurements made from magnified displays depends solely on the B sweep rate accuracy as listed in Section 1 of this manual.

Demonstration 4

Delayed Trigger

Ordinarily the displayed signal is also used to trigger the oscilloscope sweep. In some situations, it may be desirable to reverse this situation. The sweep-related output pulses, available from the front panel of the Type 546, can be used as a triggering signal for an external device. The output signal of the external device can then produce a stable display while the oscilloscope sweep free-runs.

To demonstrate one method of performing this operation, proceed as follows:

Set the controls and switches on the instrument as listed in Table 2-1 except as follows:

B SOURCE	EXT
DELAY-TIME MULTIPLIER	1.00
B TIME/CM OR DELAY TIME	10 μ SEC
A TIME/CM	1 μ SEC

Connect DLY'D TRIG to the vertical input. The display should consist of a positive-going spike.

The oscilloscope display shows the pulse that is available at the Type 546 at the end of each delay period. In a practical application, the pulse would not be applied to the vertical input, but to some external device to be tested. The pulse would serve as the trigger pulse, or input signal

for the external device and the output of the device will provide a stable display on the oscilloscope, as though the oscilloscope were triggered in the normal manner.

Demonstration 5

Pulse Generation

The +GATE A output signal of the Type 546 can be used as a variable repetition rate, variable duty factor pulse generator. To use the Type 546 in this manner, proceed as follows:

Set the controls and switches of the instrument as listed in Table 2-1 except as follows:

DELAY-TIME MULTIPLIER	About 0.20
-----------------------	------------

Monitor the signal available at the +GATE B connector on another oscilloscope and establish the desired pulse repetition rate by setting the B TIME/CM OR DELAY TIME switch and VARIABLE B. Establish the desired duty factor by setting A TIME/CM.

The maximum pulse repetition frequency that can be obtained in this manner is about 130 kc. Maximum duty factor is about 0.9, decreasing to about 0.15 with faster sweep rates.

TRIGGERED DELAYED SWEEP

Complex signals contain a number of individual events at different amplitudes. Since the trigger circuits in the Type 546 respond to signal amplitude, a stable display will normally be obtained only when the sweep is triggered by the event having the greatest amplitude.

The following instructions demonstrate that Time Base A can be triggered by virtually any event within a series of events, regardless of relative amplitude.

Set the controls and switches on the instrument as listed in Table 2-1.

Connect the AMPLITUDE CALIBRATOR signal to the vertical input. You should obtain a square-wave display.

Turn DELAY-TIME MULTIPLIER about 2 turns in either direction. Notice that the brightened segment in the display moves smoothly across the crt.

Set the DELAY-TIME MULTIPLIER so the brightened segment begins about in the middle of a pulse top. Now, set the A MODE to TRIG and the A SOURCE to NORM. Notice that the brightened segment in the display has shifted to the next pulse on the right. (If the brightened segment does not appear, or is unstable, readjust A TRIGGERING LEVEL). Turn the DELAY-TIME MULTIPLIER dial several full turns. The brightened segment in the display should jump from one pulse to the next. Set HORIZONTAL DISPLAY to A DLY'D and notice that the display now begins on the rising portion of the pulse. With the present display, if you turn the DELAY-TIME MULTIPLIER dial you will see no change in the display since all of the AMPLITUDE CALIBRATOR pulses are the same shape. However, if the input signal consisted of a repeating series of several dissimilar pulses, turning the dial would provide a triggered display of each pulse in the series (providing A TRIGGERING LEVEL is set for triggering on the smallest pulse).

Operating Instructions — Type 546/RM546

The display is produced in the following manner:

Time Base A produces one sweep during each B sweep. The Time Base A sweep will begin at some time after the start of B sweep. This time is the total of (1) the B TIME/CM OR DELAY TIME setting multiplied by the DELAY-TIME MULTIPLIER setting, plus (2) the time between the end of this delay interval and the next event in the signal which can trigger Time Base B.

The Time Base A sweep will occur only if A is triggered before the B sweep ends. If B sweep ends while the A sweep is in progress, A sweep will also terminate. If this occurs, the A DLY'D display will not be the full width of the graticule.

EXTERNAL HORIZONTAL DEFLECTION

For special applications, you can produce horizontal de-

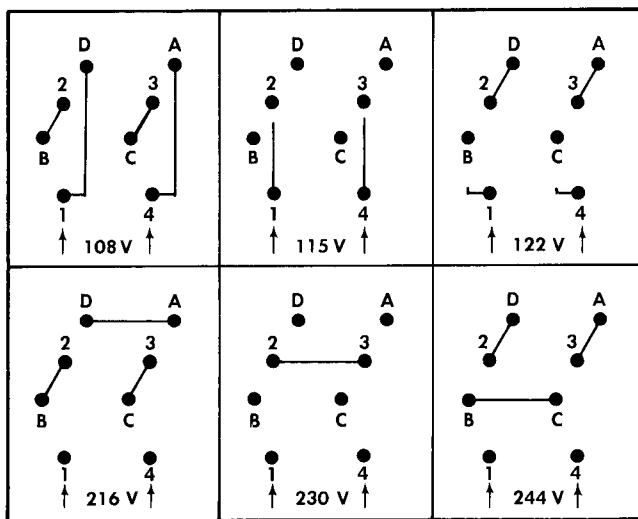

Fig. 2-5. Transformer connections for 108 to 244 volt, 50 to 60 cps and 400 cps operation.

flection with an externally derived signal. This permits use of the oscilloscope system to plot one function against another (e.g. Lissajous figures). However, the system is not intended for precision phase-angle measurements.

To use an external signal for horizontal deflection, connect the signal to the HORIZ INPUT connector. Set HORIZONTAL DISPLAY to EXT. The signal is dc coupled to the deflection amplifier. The MAG switch is inoperative when the HORIZONTAL DISPLAY switch is set to either external horizontal position.

Transformer and Fan Connections

See Figs. 2-5 and 2-6 for transformer and fan connections necessary to operate the Type 546 at line voltages from 108 to 244 volts, 50 to 60 cps and 400 cps.

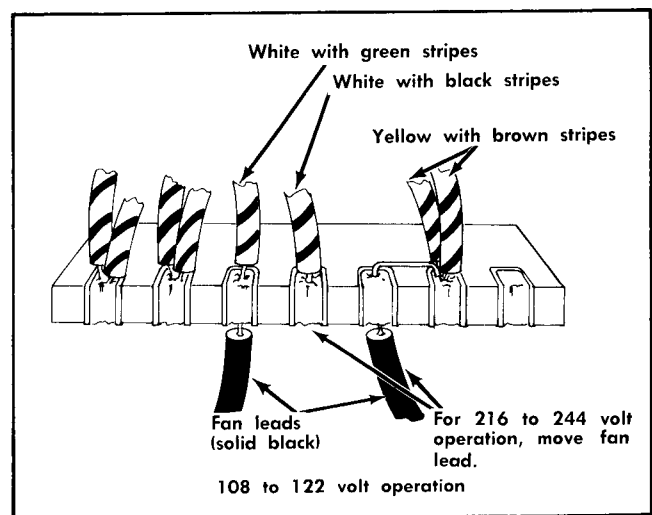

Fig. 2-6. Fan connections for 108 to 244 volt, 50 to 60 cps and 400 cps operation.

SECTION 3

CIRCUIT DESCRIPTION

Introduction

This section contains the theory of operation of the various circuits in the Type 546. A simplified block diagram analysis is given first to explain the operation of each circuit in general terms, then the operation of each circuit is covered in detail.

BLOCK DIAGRAM ANALYSIS

In the following analysis, it is assumed that the oscilloscope is equipped with a dual-channel vertical plug-in preamplifier, and that the horizontal display switch is set in the A DLY'D BY B position. Fig. 3-1 is a simplified block diagram showing the Type 546 operating in this mode. The functions of the various blocks in Fig. 3-1 are explained in the following paragraphs.

Low-Voltage Power Supply. The low-voltage power supply produces all operating voltages for the oscilloscope with the exception of parts of the crt circuit. The low-voltage supply provides regulated -150 , $+100$, $+225$, and $+350$ volts. It also provides heater voltages and an unregulated $+325$ -volt output.

Vertical Plug-In Preamplifier. Any Tektronix letter-series or 1-series vertical plug-in preamplifier can be used with the Type 546. For a circuit description of the plug-in unit, refer to the plug-in unit instruction manual.

Vertical Input Amplifier. The vertical input amplifier is a balanced, hybrid amplifier that amplifies the output of the plug-in vertical preamplifier and applies the amplified vertical signal to the trigger-pickoff circuit and the vertical output amplifier.

Delay Line. The push-pull output of the vertical input amplifier is applied through the balanced delay line to the vertical output amplifier. The delay line is a specially braided 186-ohm line which delays the application of the vertical signal to the vertical output amplifier for 170 nsec. This provides time for unblanking the crt and starting the horizontal sweep before the vertical signal reaches the deflection plates. The delay allows the leading edge of a single fast-rising pulse to be displayed. The delay line requires no adjustment because of the precision construction.

Vertical Output Amplifier. The vertical output amplifier is a push-pull, three-stage, transistor amplifier that takes the output of the delay line and amplifies it to a level sufficient to drive the vertical deflection plates of the crt.

Trigger-Pickoff Circuit. The trigger-pickoff circuit applies a sample of the input waveform to the trigger circuits of both time bases. The trigger is picked off at the output of the vertical input amplifier.

Main Time Base (B) Generator. The Main Time Base (B) generator provides accurate ramp voltages for the horizontal deflection system, unblanking for the crt, and a $\text{H} \text{B}$ gate to a front-panel connector. The Main Time Base (B) generator may be triggered by signals derived from either internal or external sources.

Delay-Pickoff Circuit. The delay-pickoff circuit compares the ramp-voltage output of the Main Time Base (B) generator with a variable reference voltage, and assuming identical characteristics in the two halves of the comparator, generates a trigger pulse when the two voltages are equal. The trigger output of the delay-pickoff circuit may be used to arm or trigger Time Base A, and is also available at a front-panel connector.

Horizontal Amplifier. The input to the horizontal amplifier is selected from the outputs of the Main Time Base (B) generator, Time Base A generator, or the external horizontal input amplifier. The selected input is split in-phase and amplified to provide push-pull drive to the horizontal deflection plates of the crt.

External Horizontal Amplifier. The external horizontal input amplifier provides the necessary gain to drive the horizontal amplifier from external signals. An input attenuator and a gain control provide horizontal deflection factors from 0.1 to about 10 volts/cm.

Crt Power Supply. The crt power supply provides the high voltages for operating the crt. The power supply is of the rf type, using a 50-kc Hartley oscillator. Secondary windings on the oscillator transformer supply voltages to the high-voltage rectifiers.

Cathode Ray Tube (Crt). The cathode-ray tube used in the Type 546 is a flat-faced, internal graticule, 5-inch tube with 6 cm of useable vertical scan area. The tube is designed for low input capacitance to the vertical deflection plates and minimum x-axis center-to-edge defocusing.

Calibrator. The calibrator in the Type 546 is a multivibrator and cathode follower that provides a square-wave output with a maximum amplitude of 100 volts at a nominal 1 kc. A step attenuator permits switching the output amplitude from the front panel. In the 0.2-mvolt to 200-mvolt range, the output impedance is 50Ω .

Time Base A Generator. The Time Base A generator closely resembles the Main Time Base (B) generator. The description of functions and the circuit analysis given for the Time Base (B) generator in most instances apply also to the Time Base A generator.

CIRCUIT ANALYSIS

The following circuit analysis of the Type 546 describes the operation of the various circuits in detail. While reading through the description of a particular circuit, refer to the circuit diagram being discussed (see Section 6).

Low-Voltage Power Supply

The low-voltage power supply in the Type 546 (see Power Supply schematic) actually consists of four interrelated supplies that operate together as a system. This system delivers filtered and regulated voltages of -150 , $+100$, $+225$, and $+350$ volts as well as an unregulated dc voltage of $+325$ volts. A common power transformer, T601, supplies the input power to each of the supplies, as well as heater power to time-delay relay K600 and the tubes in

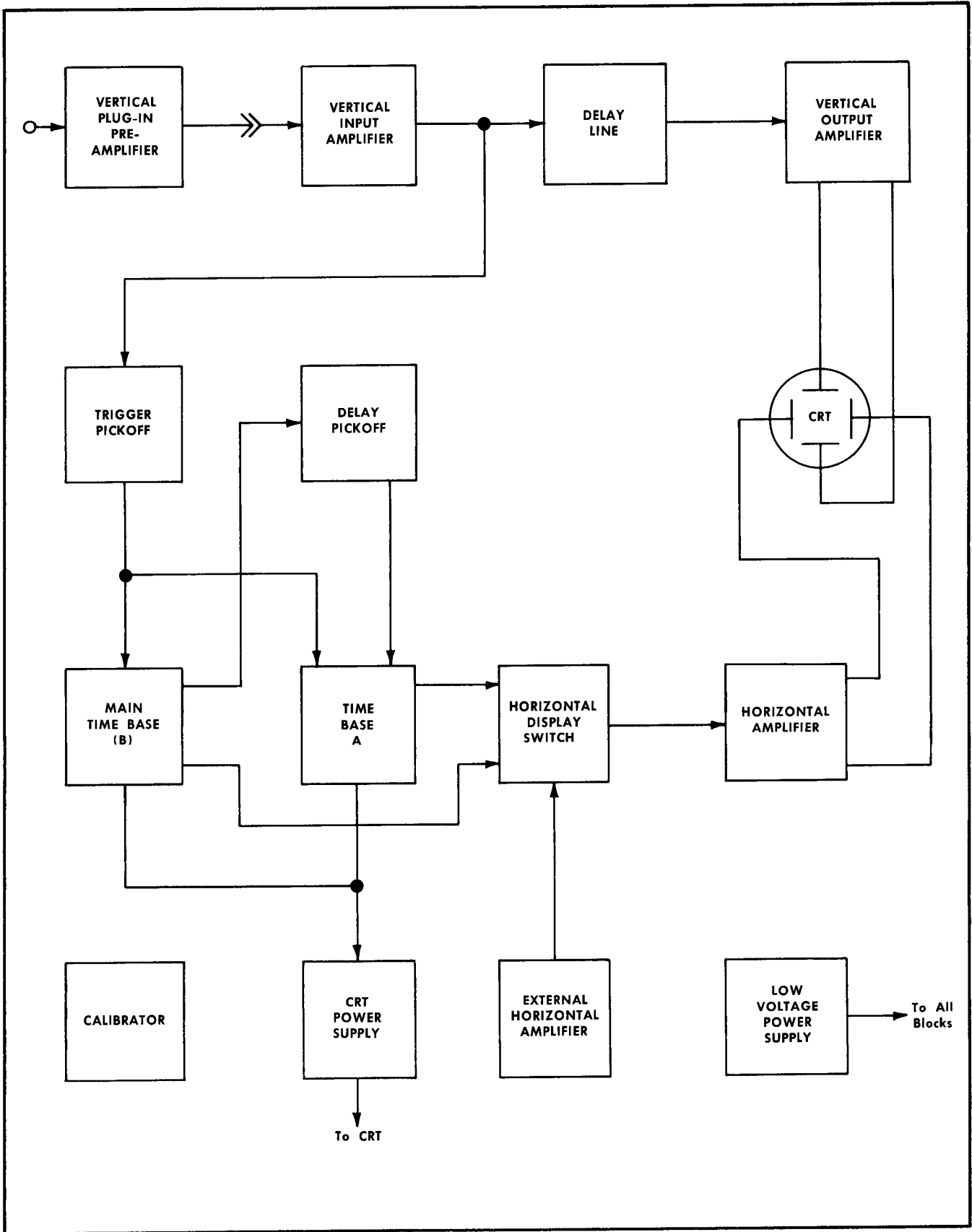

Fig. 3-1. Type 546 simplified block diagram.

the oscilloscope. Unless otherwise specified, the Type 546 is shipped with T601 wired for 115-volt ac input. A connection diagram on the side of the transformer shows alternate connections for other input voltages. An optional AC converter is available to provide 60-cycle power for the fan motor if it is desired to operate the oscilloscope on line frequencies above 60 cycles.

The 115-volt ac input power is applied to T601 through POWER ON switch SW601. Overload protection is provided by fuse F601. Thermal cutout TK601 in the primary circuit of T601 is a protective device that opens the transformer primary circuit if the temperature inside the oscilloscope rises above a safe value. TK601 resets automatically when temperatures return to normal; and to shorten the cooling time, the fan continues to run while TK601 is open (except when T601 is connected for 210-250-volt operation). Thermal time-delay relay K600 provides a filament warmup time of approximately 30 seconds before the dc power supplies are activated. The heater of K600 is rated at 6 volts and is connected to 6.3 volts on the T601 secondary winding. During heater warmup time, contacts 4 and 9 of relay K600 remain open. At the end of heater warmup time, contacts 4 and 9 close and apply power to magnetic relay K601. Contacts K601-1 of relay K601 remove the heater power from K600, but before K600 can open, contacts K601-1 lock the holding circuit to the coil of K601. K601 now remains energized until the power to the oscilloscope is switched off or otherwise interrupted. When K601 is energized, contacts K601-2, K601-3, K601-4, K601-5 and K601-6 are also closed and thus activate their respective dc supplies.

150-Volt Supply. The —150-volt supply in the Type 546 is the reference voltage source for the other supplies and must be very stable. The —150-volt supply includes a high-gain electronic voltage regulator designed to give good regulation under extreme operating conditions. This regulator circuit contains a series regulator, a glow-discharge tube reference source, an error detector, and an amplifier.

In operation, the input power to the —150-volt supply is supplied by one secondary winding of T601. The ac output of the secondary winding is rectified by silicon-diode rectifier bridge D642 and filtered by capacitor C642A. In series with the positive side of the supply and ground are series regulator tubes V637 and V647, paralleled by shunting resistors R646 and R647. The output of the —150-volt supply is taken from the negative side.

Error sensing in the voltage-regulator circuit is accomplished by comparator tube V624. Current flow through V624 is established by the setting of the tap on R616 in the voltage divider R615, R616, and R617. The voltage on the grid of V624A is held at approximately —85 volts by reference tube V609. Assuming that the output voltage of the —150-volt supply increases due to increased line voltage or some other cause, the voltage increase appears on the cathodes of V624 and, through the tap on R616, on the grid of V624B. Due to the voltage divider, only a part of the voltage increase appears between the grid and cathode of V624B, but the full change appears on the grid and cathode of V624A. The increase is in the negative direction, therefore, V624A increases its conduction to maintain the proper bias between grid and cathode, and this holds both cathodes more or less fixed while the grid of V624B is pulled negative by the increasing negative voltage across the voltage divider. The

increasing negative voltage on the grid of V624B causes a decrease in current; thus, the plate voltage goes positive.

The positive change in plate voltage is amplified and inverted to a negative change by amplifier tube V634. The amplified error signal from V634 is applied to the grids of series regulator tubes V637 and V647. The negative-going error signal on the grids of V637 and V647 decreases the current through the tubes, effectively increasing their resistance and the voltage drop across them. The voltage necessary to provide the increased drop across the series regulator tubes and shunt resistors can only be obtained by subtracting it from the negative side of the supply, so the undesired increase in negative voltage is absorbed in the series regulators and shunt resistors. If the output of the —150-volt supply had decreased instead of increased, then the error voltage applied to the grids of the series regulators would have been positive-going. The positive-going error voltage on the grids of the series regulators would lower the resistance of the series regulator tubes, and the voltage drop across them would decrease, leaving more voltage for the negative side of the supply. Since the output voltage of the —150-volt supply depends upon the relationship of the voltage on the tap of R616 and the reference voltage from V609, accurate adjustment of the output voltage is provided by making R616 variable.

Filter capacitor C642A does not remove all the ripple from the output of the bridge rectifier, thus the series regulator circuit also helps to reduce this output ripple voltage. Any ripple between the —150-volt output point and ground reaches the grid (pin 2) of V624A via capacitor C610. This input ripple voltage is amplified by V624 acting as a cathode-coupled amplifier. The ripple output voltage at the plate (pin 6) of V624B has the same polarity as the ripple voltage at the —150-volt output. C628 couples this ripple output voltage to the grid of V634. The ripple voltage is further amplified by V634 and applied to the grids of the series regulator tubes with a polarity that opposes the original ripple voltage. Ripple in the positive side of the —150-volt supply is coupled into a degenerative feedback loop through R637 to the screen of V634.

Some of the components in the —150-volt supply are not necessary in normal operation but are included to insure proper operation of the circuit under adverse conditions. C636 provides for proper operation of the circuit when extremely low temperatures reduce the capacitance of the electrolytic filter capacitors. R640 and R641 protect against large surge currents, and C642B suppresses sudden load changes that fall outside the bandwidth of the regulator circuit.

+100-Volt Supply. The input to the +100-volt supply is the output of secondary winding 19-20 of transformer T601 and silicon diode bridge D672. In addition to its other loads, the +100-volt supply is required to supply current to a series string of filaments at all times. When the Type 546 is first turned on, relay K601 contacts are open and all the regulated supplies are inoperative. During this time, the series-string filaments are supplied by the unregulated side of the +100-volt supply through relay contact K601-4. By the time relay K600 activates K601, the series-string filaments have reached operating temperature. When K601 is activated by K600, relay contacts K601-4 shift the series string filaments to the regulated output of the +100-volt supply.

Circuit Description — Type 546/RM546

The reference voltage source is the regulated output of the —150-volt supply. V664A is the error amplifier, V664B compensates for V664A grid-cathode contact bias changes caused by changing line voltage, and V667 is the series regulator tube. The error-feedback circuit is through R650 and R651, the junction of which is connected to the grid of V664A. The top end of R650 is connected to the regulated +100-volt output, and the lower end of R651 is connected to the output of the regulated —150-volt supply to obtain reference voltage. With normal line voltages and loads, the voltage at the junction of R650 and R651 is about —1.7 volts with reference to ground; this is the operating bias of V664A.

If the load current, output voltage, or the input voltage changes (including changes due to ripple), the output of the regulated +100-volt supply starts to change also, but any change appears across R650 and R651 and is applied to the grid of V664A as a change in operating bias. Assuming that the output of the regulated +100-volt supply tries to decrease, the reduced voltage at the top end of R650 permits the voltage at the junction of R650 and R651 to go more negative than the normal —1.7 volt level at that point. The increase in negative bias on the grid of V664 reduces the flow of plate current through V664A, the voltage drop across plate load resistor R663 decreases, and the plate voltage of V664 and the grid bias of V677 go more positive. As the grid of V677 goes more positive, the resistance that V677 offers to the flow of current is decreased and the output voltage rises, compensating for the drop in output voltage which initiated regulating action. Of course, the regulator circuit can never completely compensate for a change in output voltage, for there must be an error input for the circuit to operate, but any error in output is reduced by a factor equal to the loop gain of the regulator circuit.

The screen grid of V664 is used as a signal grid for injecting a sample of any ripple or transient voltages present in the unregulated side of the +100-volt supply into the regulator circuit. The regulator circuit thereby becomes a dynamic filter for ripple reduction. The ripple signal is applied to the screen of V664A, amplified and inverted in phase by V664A, then applied to the grid of V667. By the time the amplified and inverted ripple gets to the grid of V667, it is of proper amplitude and phase to cancel out the ripple appearing at the plate of V677.

To keep the proper load on the +100-volt supply when the vertical plug-in preamplifier is removed, a plug-in sensing switch is built into the main frame of the Type 546 at the top rear of the plug-in compartment. When the plug-in unit is removed, the sensing switch connects a resistive load in place of the series-filament string. When it is desired to operate the plug-in unit outside the Type 546 by means of a test harness, the sensing switch must be manually operated. To manually operate the switch, pull the plastic plunger outward to the stop position.

Unregulated +325-Volt Supply. The unregulated +325-volt supply voltage source differs somewhat from the voltage sources for the —150- and +100-volt supplies. A center-tapped secondary (13-14-15) on T601 and silicon diodes D702 and D732 form a center-tapped bridge rectifier circuit with the negative side connected to the positive unregulated side of the voltage source for the +100-volt supply. The unregulated +325-volt output is taken from the transformer center-tap (14) connection.

The unregulated output of the voltage source for the +100-volt supply is approximately +180 volts. The unregulated output of the center-tapped bridge circuit is approximately +290 volts; this, added to the unregulated +180 volts provides the +470 volts. However, for the unregulated +325-volt output, the connection is made at the center tap (+145 volts) of the bridge (the midpoint of the +290 volts). Adding the +180 and +145 volts provides the desired output of +325 volts.

+225-Volt Supply. The voltage source for the regulated +225-volt supply is the unregulated +325-volt supply described in the preceding paragraphs. The regulator circuit is similar to the regulator circuit found in the —150-volt supply; the main difference being that instead of using a glow discharge tube as a reference voltage source, the reference voltage is from the —150-volt supply. The error signal is picked off the junction of precision resistors R680 and R681. The upper end of R680 is connected to the +225-volt output, and the lower end of R681 is connected to the regulated —150-volt supply. The voltage at the junction between R680 and R681 is approximately —0.9 volt which is applied through R682 and R683 to the grid of V684B. The cathodes of V684 are long-tailed to the —150-volt supply through resistor R685. The grid of V684A is grounded. The error signal is fed from the grid of V684B through the common-cathode circuit to the A side of the tube. Notice that this comparator is somewhat different from the comparator used in the —150-volt supply; the output is taken from the A side. The error signal is amplified by V684 and fed, unchanged in phase, to the voltage divider in the grid of V694. V694 also amplifies and inverts the error signal and applies it, out of phase with any change in the +225-volt output, to the grid of series regulator tube V707.

Here again, the screen of the error amplifier tube is acting as an injection grid for ripple reduction. A sample of the unregulated supply ripple is applied to the screen of V694. V694 amplifies the ripple, inverts it in phase, and applies it to the grid of series regulator tube V708. The result is that the same ripple appears simultaneously on the grid and plate of V707, but 180° out of phase; thus the ripple cancels out.

+350-Volt Supply. The input to the +350-volt supply is the full voltage output of the center-tapped bridge (see description of +325-volt supply) added to the unregulated side of the +100-volt supply. The operation of the regulator circuit is very similar to the operation of the +100-volt regulator except for different component values and no grid cathode contact-bias compensating diode.

Crt Circuit

The crt circuit (see Crt schematic) includes the crt, the high-voltage power supply, and the controls necessary to focus and orient the display. The crt (Tektronix Type T5470-31-2) is an aluminized, 5-inch, flat-faced, glass crt with a helical post-accelerator and electrostatic focus and deflection. The crt circuit provides connections for externally modulating the crt cathode. The high-voltage power supply is composed of a dc-to-50 kc power converter, a voltage-regulator circuit, and three high-voltage outputs. Front-panel controls in the crt circuit adjust the trace rotation (screwdriver adjustment), intensity, focus, and astigmatism. Internal controls adjust the geometry and high-voltage output level.

High-Voltage Power Supply. The high-voltage power supply is a dc-to-ac converter operating at approximately 50 kc with the transformer providing three high-voltage outputs. The use of a 50-kc input to the high-voltage transformer permits the size of the transformer and filter components to be kept small. A modified Hartley oscillator converts dc from the +325-volt unregulated supply to the 50-kc input required by high-voltage transformer T801. C808 and the primary of T801 form the oscillator resonant tank circuit. No provisions are made for precise tuning of the oscillator tank since the exact frequency of oscillation is not important.

Voltage Regulation. Voltage regulation of the high-voltage outputs is accomplished by regulating the amplitude of oscillations in the Hartley oscillator. The —1850-volt output is referenced to the +350-volt regulated supply through a voltage divider composed of R841, R842, R843, R845, R846, R847, R853 and variable resistors R840 and R846. Through a tap on the voltage divider, the regulator circuit samples the —1850-volt output of the supply, amplifies any errors and uses the amplified error voltage to adjust the screen voltage of Hartley oscillator V800. If the —1850-volt output changes, the change is detected at the grid of V814B. The detected error is amplified by V814B and V814A. The error signal at the plate of V814A is direct coupled to the screen of V800 by making the plate-load resistor of V814A serve as the screen-dropping resistor for V800. Any change in the —1850-volt output thus changes the screen voltage of V800 and the amplitude of the 50-kc oscillations. R840 provides a means of controlling the high-voltage output through controlling oscillation amplitude.

Crt Grid Supply. The approximately —1950-volt output of the high-voltage power supply is the rectified output of one of the two high-voltage secondaries on T801. To provide dc-coupled unblanking signals to the crt grid, the crt grid supply is floating (the dc voltage levels on the components shift in accordance with the unblanking signals). The positive side of the crt grid supply is returned to the —150-volt supply through the unblanking cathode-follower load resistor of the selected sweep generator and through R831 and R832. The negative side of the crt grid supply is applied through the INTENSITY control to the crt grid.

At the fastest sweep rates, the stray capacitance of the floating crt grid circuit makes it difficult for the crt grid to rise fast enough to unblank the crt in the required time. An isolation network consisting of R827, R828, C828, C829, and C830 isolates the capacitive loading. By this arrangement, the fast leading edge of the unblanking pulse is coupled through C830 and C828 to the grid of the crt. For short-duration unblanking pulses, such as those that occur at the fastest sweep rates, the dc levels on the rectifier and secondary winding are not appreciably affected. Longer unblanking pulses, such as those that occur at the slower sweep rates, charge the stray capacitance in the —1950-volt output through R827. This pulls up the floating crt grid circuit and holds the crt grid at the unblanked potential for the duration of the unblanking pulse.

+8150- and —1850-Volt Outputs. Both the +8150- and the —1850-volt outputs are derived from the same secondary winding on T801. The full secondary voltage of approximately 2900 volts is applied to a voltage tripler consisting of rectifiers V832, V842, and V852 and associated capacitors. A tap on the secondary provides the input for half-wave rectifier V862 in the —1850-volt output. Both out-

puts are referenced to the regulated +350-volt supply through a voltage divider network. The +8150-volt output is connected to the crt post-deflection-accelerator anode and the —1850-volt output is connected to the crt cathode, providing a total accelerating voltage of 10,000 volts.

Crt Circuit Controls and Connectors. Optimum size and shape of the fluorescent spot on the crt is obtained by adjusting the front-panel FOCUS and ASTIGMATISM controls. FOCUS control R846 provides the correct voltage for the second anode (focus ring) in the crt. Proper voltage for the third anode is obtained by adjusting ASTIGMATISM control R864. In order to obtain optimum spot size and shape, both the FOCUS and ASTIGMATISM controls are adjusted to provide the proper electronic lens configuration in the region of the second and third anodes of the crt. Spot intensity is adjusted by means of front-panel INTENSITY control R826. Varying the INTENSITY control changes the voltage on the crt grid, which in turn varies the density of the electron stream. Internal GEOMETRY control R861 adjusts the isolation shield voltage in the crt, and is adjusted to minimize "bowing" or "tilting" of the display. Front-panel TRACE ROTATION control R778 permits minor adjustments in trace orientation. By adjusting the TRACE ROTATION control, the trace can be made parallel with the horizontal lines on the graticule, eliminating the need to physically turn the crt to correct for minor deviations of the trace from the horizontal.

An input binding post on the rear panel of the Type 546 provides an input for externally modulating the crt cathode. The input binding post is normally grounded by a link. If it is desired to intensity modulate the display from an external source, the link is opened, and the modulating signal is coupled to the crt cathode through C858.

When the Type 546 is used with a multichannel vertical plug-in preamplifier that provides dual-trace chopped blanking pulses, the blanking pulses are applied to rear-panel CRT CATHODE SELECTOR switch SW858. With the vertical plug-in preamplifier operating in the chopped mode and SW858 set to the CHOPPED BLANKING position, a positive pulse of approximately 20-volts amplitude is applied through C858 to the cathode of the crt. At normal intensity levels, this pulse is sufficient to cut off the crt during the time the amplifier channels in the vertical plug-in preamplifiers are being switched.

Vertical Amplifier System

The vertical amplifier system in the Type 546 consists of an appropriate vertical plug-in preamplifier, a push-pull cathode-follower input stage, a push-pull transistorized delay-line driver, a delay line, and a push-pull transistorized output amplifier. In addition, the trigger-pickoff circuit functions as a part of the vertical amplifier by providing reverse termination for the delay line.

Vertical Input Amplifier. The push-pull output of the vertical plug-in preamplifier, with a fixed dc level of approximately +67.5 volts, is applied to the input of the vertical amplifier through terminals 1 and 3 of the plug-in connector.

Transient-response compensation switch SW1000, capacitor C1000, and resistor R1000 at the input of the vertical amplifier compensate for the difference in transient response that

Circuit Description — Type 546/RM546

exists between different models of vertical plug-in preamplifiers. SW1000 is actuated by a mechanical sensing device when the plug-in unit is inserted into the oscilloscope, and requires no attention on the part of the operator.

R1001 and R1011, in series with the grids of the push-pull cathode-follower stage, are parasitic suppressors. Input cathode followers V1003A and V1003B are the two halves of a 12AT7 twin triode. The cathodes of the cathode followers are returned to ground through vertical dc balance control R1004, which is adjusted to equalize the dc voltage (about +68.5 volts) on the bases of delay-line driver transistors Q1014 and Q1024. The heaters of V1003 are operated as part of the series string which receives power from the +100-volt dc supply. The use of dc on the heaters prevents changes in line voltage from affecting the gain of the vertical amplifier.

The balanced delay-line driver stage is a push-pull amplifier with an adjustable vertical gain control (R1017) connected in the emitter circuit of the two transistors. Gain is adjusted by controlling the amount of degeneration in the emitter circuit. Zener diode D1018 sets the operating points of the termination transistors on both ends of the delay line. The rc networks in the collectors of Q1014, Q1024, Q1144, Q1154, and in the emitter leads of Q1034 and Q1044 set the individual transistor operating points to achieve thermal balance. The 5-turn center-tapped coils at the input of the delay line and the collector-base capacitance of the delay-line driver transistors form a T-section matching network. C1029 provides a means of varying the impedance of the T section.

Vertical Output Amplifier. The vertical output amplifier must properly terminate the delay line and provide broad-band amplification of the vertical signals. Proper termination of the delay line is obtained by connecting forward-termination transistors in a common-base configuration. The common-base configuration also operates well in broad-band amplifier applications. To help meet the broad-band requirement, the collector load circuit of the termination transistors contain rc low-frequency compensation networks, and in addition, lr networks in the collectors of transistors Q1034 and Q1044 compensate for losses due to skin effect within the delay line.

Following the forward-termination amplifier is a wide-band amplifier stage consisting of Q1074 and Q1084 and associated elements. High-frequency compensation in this stage is provided by shunt peaking coils L1072 and L1082 in the collector circuits. The high-frequency response is varied by adjusting C1076, which provides variable high-frequency degeneration in the emitter circuit of Q1074 and Q1084.

The output stage of the vertical amplifier is a transistorized equivalent of a push-pull cascode amplifier. This circuit configuration is used to match the low impedance of the transistorized vertical-amplifier system to the higher impedance required at the crt vertical deflection plates. High-frequency compensation is provided by rc networks between the collector of the driving transistor and the emitter of the driven transistor on each side. C1105 and C1106 provide a means of varying the high-frequency response of the output stage. The outputs from Q1114 and Q1134 are connected to the deflection plates of the crt via series-peaking coils L1115 and L1135.

Trigger-Pickoff Circuit. The trigger-pickoff circuit provides reverse termination for the delay line as mentioned in the

preceding paragraphs. The input stage of the trigger-pickoff circuit, which provides the delay-line reverse termination, is a common-base circuit. The output stage of the trigger-pickoff circuit is a push-pull emitter-follower amplifier that not only provides trigger signals to the two time bases, but supplies the VERT SIG OUT jack with a vertical signal and drives position-indicator amplifier V1184.

Main Time Base (B)

The Main Time Base (B) consists of the B sweep trigger and the B sweep generator circuits. The B sweep trigger circuit is a wide-band hybrid amplifier driving a tunnel diode. The B sweep trigger circuit includes controls for selecting the type, source, and level of the trigger to be used, and circuit elements for regenerating the selected trigger into a pulse suitable for triggering the B sweep generator. The B sweep generator provides ramp voltages for the horizontal deflection system, alternate-trace sync pulses, unblanking pulses, and +B gate pulses.

Trigger Generator. The input to the B sweep trigger circuit (see B Sweep Trigger schematic) is selected by SOURCE switch SW1 from the trigger-pickoff circuit in the vertical amplifier, the trigger output of the vertical plug-in preamplifier, the power transformer for line triggering, or from the front-panel TRIGGER INPUT connector. COUPLING switch SW5 permits further selection of the type of triggering signal; either ac, ac with low frequencies rejected, or dc. Once the type and source of triggering signal has been selected, the slope on which triggering is desired is selected by SLOPE switch SW10. The level of the triggering signal required by the B sweep trigger circuit is selected by adjusting TRIGGERING LEVEL control R15. After this triggering signal has been selected by the foregoing controls and switches, it is applied to trigger input amplifier V24.

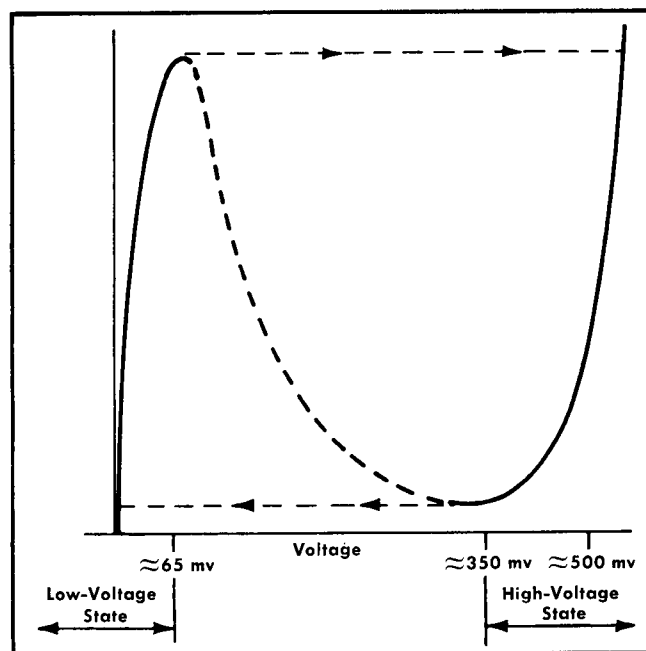

Fig. 3-2. Tunnel diode characteristics.

In operation, V24A and V24B form a push-pull amplifier which drives a push-pull input, single-ended output amplifier consisting of Q34 and Q44. Tunnel diode D45 is biased at its low-voltage state (see Fig. 3-2 for trigger tunnel-diode curve) by current flow through the voltage divider consisting of R44, R45, R47, and R48. When the desired slope of the triggering signal selected arrives at the grids of V24, V24B and Q44 are biased into conduction. The conduction of Q44 increases the current flow through D45, and D45 switches to its high-voltage state. The sudden voltage change across D45 as it switches to its high-voltage state produces a uniform fast-rising trigger pulse which is used to trigger the Main Time Base (B) sweep generator.

Sweep Generator. For purposes of explanation, assume that the HORIZONTAL DISPLAY switch (see B Sweep Generator schematic) is in the B position, the SINGLE SWEEP switch is in the NORMAL position, the TRIGGERING MODE switch is in the TRIG position and that no trigger is being applied. Under these conditions, V145A in the holdoff multivibrator is conducting and V145B is cut off. The paths for the current in V145A are from the —150-volt supply through R164 and D163 in parallel with R163. When V145A is conducting and no trigger is being received from the trigger generator, D85 is in its low-voltage state since the dc current supplied from the +100-volt supply through R82 and R81 is less than the peak current of D85. Under these conditions, Q84 is cut off. Thus, the collector voltage of Q84 is positive, forward biasing D86, D89 and Q103. Miller tube V91 is conducting. The circuit is now ready to be triggered.

Assuming that a trigger pulse is now applied, the positive trigger from the B sweep trigger circuit is coupled through C56 to L56 and D57. C56 and L56 form a differentiating network that narrows the trigger pulse to approximately 4 nsec in width. The sharpened trigger pulse passes through D59 to tunnel diode D85 and causes D85 to switch to its high state, where it remains after the trigger pulse decays to zero. When D85 switches to its high state, Q84 is biased into saturation and the voltage change across Q84 applies forward bias to Q173 and reverse biases Q89, Q103, and D86. When D86 is reverse biased, the voltage on the grid of V91 goes negative and the Miller circuit starts to run up. As the voltage on the cathode of V93A goes positive, it starts to charge timing capacitor C90 through D98. At high sweep rates, boot-strap capacitor C94 couples the rising cathode voltage to the plate circuit of V91 and effectively increases the plate supply voltage for V91, compensating for losses introduced by stray capacitance. In addition, the positive-going cathode voltage of V93A forward biases D129 and starts putting a positive voltage on the grid of V145B in the holdoff multivibrator. At a point determined by sweep-length resistor R125, the rising positive voltage biases V145B into conduction, and the holdoff multivibrator changes state, cutting off V145A. When V145A cuts off, its cathode voltage drops to —20 volts and reverse biases D85 and Q84. As current flow through Q84 ceases, the voltage increase across it again forward biases D86. When D86 becomes forward biased, it applies a positive-going voltage to the grid of V91 which resets the Miller circuit and ends the sweep.

Disconnect diode D100 ensures that the sweep starts from the same voltage point each time. Q103 is included in the circuit to reduce the amount of current that D100 has to switch, and thereby improves the linearity at the start of the sweep.

When the sweep ends, V145B has control of the holdoff multivibrator, and remains in control until the charge on hold-off capacitor C130 discharges through R130. During the time that V145B has control of the holdoff multivibrator, tunnel diode D85 cannot be triggered; but when the holdoff capacitor discharges to the point where V145A can again assume control, D85 is again biased to a point where it can accept another trigger.

Automatic Stability Circuit. Q65, Q75, and associated circuit components form a monostable multivibrator that controls the stability of the B sweep generator. When the trigger MODE switch is in the TRIG position, the switch grounds the collector of Q75 and disables the automatic stability feature of the Type 546. When the triggering MODE switch is in the AUTO STABILITY position, the sweep generator free runs if no trigger pulses are received from the trigger generator.

In normal operation Q65 is conducting due to the positive voltage applied to its base. Q75 is normally cut off due to its base being grounded through R69. When the trigger MODE switch is set to the AUTO position, C76 starts to charge through R76. When the voltage across C76 exceeds the break-down of Zener diode D76, D76 breaks down and provides an additional current path for tunnel diode D85. The additional current through D85 causes it to switch to its high state and start the sweep. When the sweep ends and the holdoff multivibrator switches, the voltage on the cathode of V145A drops to approximately —20 volts, reverse biasing D85. When the holdoff period ends, the cathode voltage of V145A goes slightly positive, and the current through D76 again switches D85. If no trigger is applied, the cycle repeats only if the trigger MODE switch is in the AUTO position.

When a trigger pulse is received at T52, a negative output from the secondary is applied to the base of Q65 and causes the monostable multivibrator to switch. With Q65 now cut off, its collector voltage goes more positive, and C67 charges through R69, applying a positive voltage to the base of Q75. The positive voltage on the base of Q75 biases it to saturation, and Q75 provides a low-resistance path that discharges C76 and reverse biases D79 and D76. With the collector of Q75 below the D76 breakdown voltage, the collector circuit does not provide switching current for tunnel diode D85, so the only way D85 can be switched is by the application of a trigger pulse. If no further trigger pulses are received, Q75 is kept in saturation until the charge current for C67 decays and removes the positive voltage from the base of Q75.

During the charge time of C67, Q65 is kept cut off by the forward voltage drop across D71. When the decaying charge current removes saturation bias from Q75, the voltage drop across D71 decreases and permits Q65 to conduct, and the multivibrator switches back to its normal state. If no further trigger pulses are received, C76 charges through R76 and R75 until D76 again breaks down and provides switching current for D85.

Unblanking Circuit. With the HORIZONTAL DISPLAY switch set in the B position, an unblanking pulse is generated and applied to the crt unblanking circuit during B sweep time. The unblanking pulse is initiated when tunnel diode D85 switches to its high state and biases Q84 into conduction. When Q84 conducts, its collector voltage drops and removes the cutoff bias from Q173, biasing Q173 into conduction. When Q173 conducts, it puts a positive-going voltage on the

Circuit Description — Type 546/RM546

grids of cathode followers V193A and V193B. The positive-going voltage on the cathode of V193B is coupled to the crt-unblanking supply. The output of V193A is applied to the +GATE B connector on the front panel and to pin C of J435.

Single-Sweep Circuit. When single-sweep operation is desired, NORMAL - SINGLE SWEEP - RESET switch SW135 is set to the SINGLE SWEEP position. When SW135 is pushed to the RESET position, it operates switch SW369 which discharges C369 (see A Sweep Generator schematic) through R369, R368, and R367, generating a positive pulse which is applied through C166 and D164 to the cathode of holdoff tube V145B. The positive pulse on the cathode of V145B causes the holdoff multivibrator to switch, and V145A biases sweep tunnel diode D85 to the ready point as previously explained. Since Q84 and V145B are both cut off, the positive voltage on the collector of Q84 and the voltage on the plate of V145A combine through R87 and R142 and produce turn-on bias for Q89. When Q89 conducts, it completes the circuit for the NE-23 READY lamp (B89). With the application of a trigger pulse, Q84 conducts and the voltage on its collector drops, removing the bias on Q89 and thereby extinguishing the READY lamp. The runup of the Miller circuit causes the hold-off multivibrator to switch, and V145B takes control. NORMAL - SINGLE SWEEP - RESET switch SW135 applies a positive voltage through D132 to the grid of V145B, and this positive voltage prevents the holdoff multivibrator from resetting until NORMAL - SINGLE SWEEP - RESET switch SW369 has been moved to either the RESET or NORMAL position.

Main Time Base (B) Sweep Timing. The sweep rate (the rate at which the spot moves across the face of the crt) is determined by the rate at which the timing capacitor and timing resistor permit the Miller circuit to run up. By means of TIME/CM OR DELAY TIME switch SW90 (see B Sweep Timing-Switch schematic), both the size of the capacitor being charged and the charging current can be selected to cover a wide range of sawtooth slopes (sweep rates). Note that SW90 is connected so that switching 8 capacitors and 6 resistors provides 24 different sweep rates, varying from 5 sec/cm to 0.1 μ sec/cm without magnification. The TIME/CM OR DELAY TIME switch also selects the proper holdoff capacitor and discharge resistor for the sweep rate in use.

Continuously variable uncalibrated sweep rates are provided by R90Z and SW90Z (VARIABLE control). When SW90Z is switched to the UNCAL position, it removes the short from around R90Z and switches on UNCAL lamp B90W. By turning VARIABLE control R90Z, the charging time of the timing capacitor selected by the TIME/CM OR DELAY TIME switch may be increased by at least 2.5 times the calibrated rate, providing continuously variable sweep rates.

Delay-Pickoff Circuit. The delay-pickoff circuit (see Delay Pickoff schematic) generates a trigger pulse that is delayed from the start of the B sweep by an amount determined by the settings of the Main Time Base (B) TIME/CM OR DELAY TIME switch and the DELAY TIME MULTIPLIER dial. A comparator in the delay-pickoff circuit continuously monitors the ramp output voltage of the Main Time Base (B) Miller runup circuit and compares the ramp voltage with a voltage level established by the setting of the DELAY TIME MULTIPLIER dial. When the ramp voltage biases V404A into conduction, the comparator switches a tunnel diode. The tunnel diode generates a trigger pulse that is delayed from the start of

the B sweep by the time it takes the ramp voltage to rise to a value approximately equal to the voltage established by the DELAY TIME MULTIPLIER dial setting. After being amplified, the delayed trigger is applied through the HORIZONTAL DISPLAY switch as a source of delayed trigger for the Time Base A generator, and to the DLY'D TRIG output connector on the front panel for use in external equipment. Delayed trigger pulses are connected to the Time Base A sweep generator when the HORIZONTAL DISPLAY switch is in the B INTEN BY A and A DLY'D BY B positions.

In actual operation, the comparator is longtailed through a constant-current tube that keeps the current through the comparator relatively constant despite the large voltage swings applied to the grids. The grid voltage of constant-current tube V93A is fixed at approximately -56 volts by the voltage divider consisting of R406 and R407. With the grid of V93A biased at approximately -56 volts, R409 maintains the current through V93B (and thereby the comparator tube) to approximately 5 ma.

Comparator tube V404 receives the ramp output of the Main Time Base (B) sweep generator on one grid and the voltage from the tap on delay-time helipot R416 on the other. At the start of the ramp, V404B is conducting and V404A is cut off. Assume that the ramp input to the comparator is increasing at the rate of 10 volts/msec, and the DELAY TIME MULTIPLIER dial is set at 2.0 (2.0 is equal to 20 volts of a 100-volt ramp), then the voltage on each grid of the comparator becomes 20 volts 2 msec after the ramp starts. At this point, V404A starts conducting. V404A draws current through R404, L404 and tunnel diode D405. The current flow through D405 causes it to switch to its high state, generating a sharp trigger pulse. R404 and L404 narrow the hysteresis zone of D405. The low resistance of R404 would attenuate the trigger pulse if it were not for the high-frequency peaking effect of L404. The trigger voltage developed across D405 is amplified by Q424 and applied to Q433 through a differentiating network. The output of Q433 is applied to the DLY'D TRIG connector on the front-panel and to the HORIZONTAL DISPLAY switch as previously mentioned.

Jack J435 provides a means of coupling in an externally-generated delayed trigger. Terminals B and C provide function information to the external trigger generator, and the externally-generated delayed trigger is applied to terminal A. It is also necessary to apply sufficient dc bias to terminal A to back bias D433.

Time Base A

Time Base A in the Type 546 is similar to the Main Time Base (B) sweep generator and the circuit description of the operations of Main Time Base (B) generally applies to Time Base A. The two trigger generator schematics, in particular, show few differences other than circuit symbols. The major circuit differences in the two time bases are the Single Sweep switch, the delayed sweep lockout circuits, and cathode follower V293B which appear on Time Base A schematic but not on B. Cathode follower V293B provides a sample of the A sweep ramp to the front panel; the functions of the Single Sweep switch and delayed sweep lockout circuits for each setting of the HORIZONTAL DISPLAY switch are given in the following paragraphs.

Position A. With the HORIZONTAL DISPLAY switch in this position and the Single Sweep switch in the NORMAL position, the operation of Time Base A is the same as the operation of the Main Time Base (B) when the HORIZONTAL DISPLAY switch is in the B position as previously described. If the Single Sweep switch is placed in the SINGLE SWEEP position, Time Base A operates as follows:

The holdoff multivibrator is armed by pressing the Single Sweep switch to RESET or by feeding in an external reset signal through EXTERNAL SINGLE SWEEP INPUT jack J367. The reset pulse cuts off V345A and makes V345B the conducting half of the holdoff multivibrator. If the Time Base A TRIGGERING MODE switch is in the AUTO position, the sweep triggers automatically. If the TRIGGERING MODE switch is in the TRIG position, the sweep triggers on the next trigger pulse from the A Sweep Trigger Generator. Once the sweep runs up, the positive voltage at the junction of R331 and R332 keeps the holdoff multivibrator in holdoff until it is again armed by a reset pulse from the Single Sweep switch or from the external single sweep input.

Position B. In this position of the HORIZONTAL DISPLAY switch, Time Base A operates in the same manner as described for the A position, but the A sweep is not applied to the horizontal amplifier and does not appear on the crt.

Position B INTENS BY A. In this position of the HORIZONTAL DISPLAY switch the external single sweep reset feature is disabled by wafer 3F. The auto circuit is disabled by wafer 4R. Wafer 5R connects the holdoff capacitor to a positive voltage source to increase the holdoff time. With the TRIGGERING MODE switch in the AUTO position, the MODE switch grounds the junction of R334 and R335, removing the lockout voltage from V345A in the holdoff multivibrator. With the lockout voltage removed, the holdoff multivibrator arms tunnel diode D285 at the end of holdoff time. Triggering signals from the A sweep trigger generator cannot get through D259 since it is reverse biased due to wafer 4R and the MODE switch grounding the bottom end of R258. When the holdoff multivibrator arms at the end of the holdoff period, the next delayed trigger from the delayed trigger circuit passes through C361 and R361 and causes D285 to switch, starting the delayed sweep. The output of the A sweep generator is grounded by the HORIZONTAL DISPLAY switch and does not get to the horizontal amplifier, but the output of V393B is applied to the crt grid and intensifies B sweep during the time the delayed A sweep is running.

At the end of A sweep, it is necessary to keep B sweep from running again until A sweep is out of holdoff. When V345B is in holdoff, its cathode voltage goes negative. The negative voltage on the cathode of V345B is coupled through wafer 4F to diode D57 in the Main Time Base (B) generator. The negative voltage from the cathode of V345B reverse biases diodes D57 and D59, preventing any triggering signals from reaching D85 until the sweep circuit of Time Base A is again armed and ready for a trigger.

When it is desired to display a single sweep of B INTENS BY A, the SINGLE SWEEP switch is placed in the SINGLE SWEEP position. Main Time Base (B) generator stays in holdoff due to the positive voltage from the junction of R331 and R332 through wafer 1R to Main Time Base (B) holdoff capacitor. Setting the Single Sweep switch to RESET causes the Main Time Base (B) holdoff multivibrator to switch, arming the main time base. With the application of a trigger pulse,

B sweep runs up. If Time Base A TRIGGERING MODE switch is in AUTO, Time Base A holdoff multivibrator arms automatically and the intensified segment of the sweep starts when the delayed trigger pulse occurs. If the TRIGGERING MODE switch is in the TRIG position, the holdoff multivibrator stays in holdoff until the arrival of the delayed trigger pulse. This is due to the voltage at the junction of R334 and R335 being applied to the grid of V345A. When the delayed trigger occurs, Time Base A holdoff multivibrator arms and waits until it is triggered by a trigger pulse from Time Base A trigger generator.

Position A DLY'D. The operation of Time Base A sweep generator in this position of the HORIZONTAL DISPLAY switch is the same as described for B INTENS BY A. However, in this position of the HORIZONTAL DISPLAY switch, the output of Time Base A generator is applied to the horizontal amplifier while the output of Main Time Base (B) is grounded, and only the delayed A sweep is displayed.

EXT Positions. In these positions of the HORIZONTAL DISPLAY switch, the outputs of both sweep generators are grounded, and it is necessary to apply an external signal to the HORIZ INPUT jack on the front panel in order to get a horizontal sweep.

Alternate-Trace Sync Amplifier

The alternate-trace sync amplifier (see Interconnecting Jack J11 schematic) amplifies and shapes the alternate-trace sync pulses from the sweep generator holdoff multivibrator and applies them to the vertical plug-in preamplifier. It also provides a sample of the pulse to the crt for blanking purposes.

Horizontal Amplifier

The dc-coupled horizontal amplifier (see Horizontal Amplifier schematic) consists of a transistor input amplifier, an emitter follower, a transistor paraphase amplifier, a push-pull vacuum-tube output amplifier, a pair of output cathode followers, and a capacitance-driver tube. In addition, the Type 546 contains a cathode-coupled preamplifier that is used to amplify externally applied horizontal deflection signals. The input to the horizontal amplifier is received from the A sweep generator, B sweep generator, or the external HORIZ INPUT connector, depending upon the setting of the HORIZONTAL DISPLAY switch.

Input Stages. The selected input signal is applied to the base of Q534 along with dc-positioning voltages from the horizontal positioning controls. The composite signal output of Q534 is applied to emitter follower Q543, and from that transistor to the paraphase amplifier. Negative feedback from the emitter of Q543 to the base of Q534 keeps the input and output impedance of the two stages low. R544 (X10 CAL) in the feedback loop provides a means of adjusting the amount of feedback, thereby providing amplifier gain adjustment.

Paraphase Amplifier. Q554, Q564 and associated circuit components form a paraphase amplifier that splits the signal from Q543 into a push-pull output. The signal from Q554 to Q564 is coupled through the emitter circuit, and by changing the value of the coupling resistor, the gain of the para-

Circuit Description — Type 546/RM546

phase amplifier is changed to provide sweep magnification. Four selectable values of coupling resistor are available, providing X1, X2, X5, or X10 sweep magnification.

The feedback loop from the collector of Q554 stabilizes the gain and balance of the paraphase amplifier. D542 and D561 provide base-operating bias. The feedback loops from the output cathode followers (V574B and V584B) to the emitters of Q554 and Q564 assist in stabilizing the gain of the horizontal amplifier.

Output Amplifier and Cathode Followers. The ramp-voltage outputs of the paraphase amplifier are applied to the grids of amplifiers V574A and V584A. The ramp voltages are amplified by the two triodes, which then apply the ramp voltages to the output cathode followers. To maintain the desired linearity at high sweep rates, part of the output from each amplifier is bypassed around the cathode followers through small variable capacitors C572 and C582. C576 and C586 together with the stray capacitance across R576 and R586 form a capacitance bridge to provide correct high-frequency feedback.

Capacitance Driver. The cathode of V574B drives the left-hand deflection plate and, during the sweep, the cathode voltage should go linearly in a negative direction. At high sweep rates, when V574B tries to drive the deflection plate negative, the deflection-plate capacitance and the output capacitance of cathode follower V574B tend to distort the ideal linear ramp voltage into an rc discharge curve. To overcome this tendency toward nonlinearity, the positive-going ramp voltage at the cathode of V584B is applied through C591 to the grid of capacitance driver tube V589. The positive-going voltage on the grid of V589 forces it into heavy conduction, and the current supplied through the tube provides extra current to the cathode of V574B and helps to discharge the capacitance in the output of V574B. Since the crt is blanked during the return trace, there is no need for a similar current driver at the cathode of V584B.

External Horizontal Preamp. The preamplifier applies external horizontal deflection voltages through the HORIZONTAL DISPLAY switch to the grid of V514B. For large-amplitude signals, a X10 attenuator position is provided on the HORIZONTAL DISPLAY switch. V514B and V514A form a cathode-follower grounded-grid amplifier, with a gain controlled by adjusting the value of the coupling resistor between the two cathodes. In this case, R511 provides at least a 10:1 range of adjustment. The output of V514A is applied through the HORIZONTAL DISPLAY switch to the base of Q534.

Amplitude Calibrator

The amplitude calibrator in the Type 546 is a 1-kc square-wave generator (see Amplitude Calibrator schematic) that

provides both voltage and a 5-ma current output to the front-panel connectors. The voltage output is taken from the CAL OUT connector on the front panel, where either a selectable-amplitude square wave or a steady +100-volt dc reference voltage is available. By turning the AMPLITUDE CALIBRATOR switch, the amplitude of the square-wave output may be varied from 0.2 mvolts to 100 volts, peak-to-peak. The current output is applied to the current strap 5 mA, the arrow indicates conventional current flow. When the AMPLITUDE CALIBRATOR switch is in the 100 VDC position, the link has 5 ma dc flowing through it; when the switch is in the 5 mA position, the current through the link is in the form of a 1-kc, 5-ma square wave.

CAUTION

The link is designed for use with a snap-on current probe and does not unplug.

Square-Wave Generator. The square-wave generator is an astable multivibrator direct-coupled to a cathode follower. V935A and V945 are the multivibrator tubes, with the screen of V945 serving as an anode and furnishing feedback to V935A. The plate of V945 operates as an electron-coupled amplifier. The time constants in the grid circuits of the tubes are different to compensate for the difference in their characteristics. When the amplitude calibrator is turned on, the multivibrator cathodes are returned directly to the dc-coupled —150-volt supply. Since the plate load and grid resistors are grounded, this means that the supply potential of the multivibrator is 150 volts. The plate of V945 operates from the +225-volt supply, but is clamped slightly above 100 volts by D942 and D948. The voltage on the plate of V945 swings from about —30 volts to about +102 volts. The plate of V945 is coupled through Zener diode D948 to the grid of cathode follower V935B. CAL AMPL control R943 is adjusted so that when the signal to V935 is positive, its cathode voltage rises to +100 volts. When the signal from the V945 plate goes negative, V935B is cut off and the cathode voltage goes to ground potential.

Output Level Selection. The cathode load for V935B is essentially the string of precision resistors starting with R950 and ending with R958. The junctions of the precision resistors are connected to the CAL OUT connector through AMPLITUDE CALIBRATOR switch SW950. The values of the precision resistors are selected to give output amplitude steps in multiples of 1, 2, or 5. In the steps from 200 mvolts to 100 volts, the junctions of the precision resistors are switched through R962 to the CAL OUT connector, while in the steps from 0.2 to 100 mvolts, an additional divider with a ratio of 1000:1 is inserted between the precision resistors and the CAL OUT connector. In the 0.2 mvolt to 200 mvolt range, the output impedance is 50 Ω .

SECTION 4

MAINTENANCE

PREVENTIVE MAINTENANCE

CAUTION

Turn off power before removing or replacing parts.

General Information

The Type 546 is a stable instrument and will provide many hours of trouble-free operation. However, to maintain measurement accuracy, a visual inspection and a calibration check should be made after each 500 hours of operation or every six months if used intermittently. The calibration procedures include steps for checking the operation of various circuits. Minor troubles not apparent during regular operation will often be revealed during calibration. Major troubles in the instrument are often isolated or eliminated by recalibrating the instrument.

Visual Inspection

The Type 546 should be inspected occasionally for such defects as broken connections, broken or damaged ceramic strips, improperly seated tubes or transistors, and heat damaged parts. The remedy for most visible defects is obvious; however, particular care must be taken if heat-damaged parts are detected. Overheating is usually only a symptom of trouble. For this reason, it is essential to determine the actual cause of overheating before the heat-damaged parts are replaced; otherwise, the damage may be repeated.

Cleaning

The Type 546 must be cleaned as often as operating conditions require. Accumulations of dirt in the instrument can cause overheating and component breakdown. Dirt on the components acts as an insulating blanket (preventing efficient heat dissipation) and provides conducting paths for electricity. Dirt in the air filter chokes the flow of cooling air and leads to excessive operating temperature.

Air Filter. The air filter should be visually checked every few weeks and cleaned if dirty. More frequent inspections and cleaning are required under severe operating conditions. To clean the filter, wash it out as you would a plastic sponge. Rinse the filter, and let it dry. Coat the dry filter with fresh "Filter-Kote" (Tektronix Part Number 006-580) or "Handi-Koter." (These products are available from the local representative of the Research Products Corporation, and from some air-conditioner suppliers.) Let the filter dry thoroughly before reinstalling.

Exterior. Loose dust accumulating on the outside of the Type 546 can be removed with a cloth or small paint brush. The paint brush is particularly useful for dislodging dust on and around the front-panel controls. Stubborn dirt can be removed with a soft cloth dampened in a mild solution of water and detergent. Abrasive cleaners should not be used.

Clean the face of the crt with a soft, lint-free cloth dampened with denatured alcohol.

Interior. Although the air entering the Type 546 is filtered, some dust will eventually penetrate into the interior of the instrument. This dust should be removed occasionally due to its conductivity under high humidity conditions. The best way to clean the interior of the equipment is to first carefully vacuum all accessible areas and then blow away the remaining dust with dry low-pressure compressed air. Avoid the use of high-velocity air which might damage some of the components. Remove stubborn dirt with a soft paint brush or a cloth dampened with a mild water and detergent solution.

Pay special attention to high-voltage circuits, including parts inside the high-voltage shield. Arcing in the high-voltage circuits due to dust or other causes may produce false sweep triggering resulting in an unstable crt display.

Lubrication

The fan motor bearings should be lubricated every three or four months with a few drops of light machine oil (see Fig. 4-1). Failure to lubricate the bearings periodically can cause the fan to slow down or stop.



Fig. 4-1. Fan motor lubrication points.

CORRECTIVE MAINTENANCE

General Information

Many components in the Type 546 are mounted in a particular way to reduce stray inductance and capacitance. While removal or replacement procedures for most parts in the Type 546 are obvious, remember to duplicate lead length, lead dress, and location of the original component when installing replacement parts. Since components of the same type may exhibit slightly different characteristics, it is desirable to check the calibration of the Type 546 after completion of repairs.

Component Numbering

The component number of each electrical part is shown on the circuit diagrams. The following chart lists the component numbers associated with each circuit.

numbers less than 100	B Sweep Trigger Circuit
100-series numbers	B Sweep Generator
200-series numbers	A Sweep Trigger Circuit
300-series numbers	A Sweep Generator Circuit
400-series numbers	Delay Pickoff Circuit
500-series numbers	Horizontal Amplifier Circuit
600- and 700-series numbers	Low-Voltage Power Supply
800-series numbers	Crt Circuit
900-series numbers	Calibrator
1000- and 1100-series numbers	Vertical Amplifier

Soldering Precautions

In the production of Tektronix instruments, a special silver-bearing solder is used to establish a bond to the ceramic terminal strips. This bond may be broken by repeated use of ordinary tin-lead solder, or by excessive heating of the terminal strip with a soldering iron. Occasional use of ordinary 60-40 solder will not break the bond unless excessive heat is applied, but it is advisable to stock solder containing about 3% silver for the maintenance of Tektronix instruments. This solder may be purchased directly from Tektronix in one-pound rolls; order by Part Number 251-514.

Because of the shape of the ceramic-strip terminals, it is recommended that a soldering iron with a wedge-shaped tip be used. A wedge-shaped tip allows the heat to be concentrated on the solder in the terminals and reduces the amount of heat required. It is important to use as little heat as possible while producing a full-flow joint.

The following procedure is recommended for removing or replacing components mounted on ceramic strips:

1. Use a 50- to 75-watt soldering iron.
2. Tin the tip with solder containing about 3% silver.
3. Use long-nose pliers for a heat sink. Attach pliers between the component and the point where heat is applied.

4. Apply heat directly to the solder in the terminal without touching the ceramic. Do not twist the iron in the notch as this may chip or break the ceramic strip.
5. Apply only enough heat to make the solder flow freely.
6. Do not attempt to fill the notch on the strip with solder; instead apply only enough solder to cover the wires adequately and form a small fillet on the wire. Over-filling the notches may result in cracked terminal strips. If the lead extends beyond the solder joint, clip the excess as close to the joint as possible. Remove all wire clippings from the chassis.

Tubes and Transistors

Tubes or transistors should not be replaced unless they are actually defective. If tubes or transistors are removed and found to be acceptable, be sure to return them to their original sockets. Tube or transistor-tester checks on the tubes or transistors used in the Type 546 are not recommended. Testers may indicate a tube or transistor to be defective when it is operating satisfactorily in a circuit, or may fail to indicate tube or transistor defects which affect the performance of the circuits. It is recommended that tubes and transistors be checked by substitution. If the tube or transistor is good, return it to its socket. Unnecessary replacement of tubes or transistors is not only expensive but may also result in needless recalibration of the instrument.

Wafer Switches

Individual wafers are normally not replaced in the switch assemblies. If one wafer is defective, the entire switch assembly should be replaced. Switches can be ordered from Tektronix either wired or unwired. For wired and unwired part numbers, refer to the parts list in Section 6.

The wafer switches shown on the schematics are coded to indicate the position of the wafer on the switch. The wafers are numbered from front to rear (i.e., the number 1 wafer is always closest to the front panel). The letters F and R indicate the front or rear of the wafer. For example, a code designation of 3R means the rear side of the third wafer from the front panel.

Cathode-Ray Tube

To remove and replace the cathode-ray tube, perform the following procedure:

WARNING

Be careful when handling a crt. Avoid striking it on any object that might cause it to crack and implode. Flying glass from an imploding crt can cause serious injury. Use safety glasses or a plastic face mask for protection.

1. Remove the crt bezel nuts, bezel, and plastic polarized light filter (see Fig. 4-2).
2. Remove plastic eyebrow and retaining spring from the top of the crt (see Fig. 4-2).

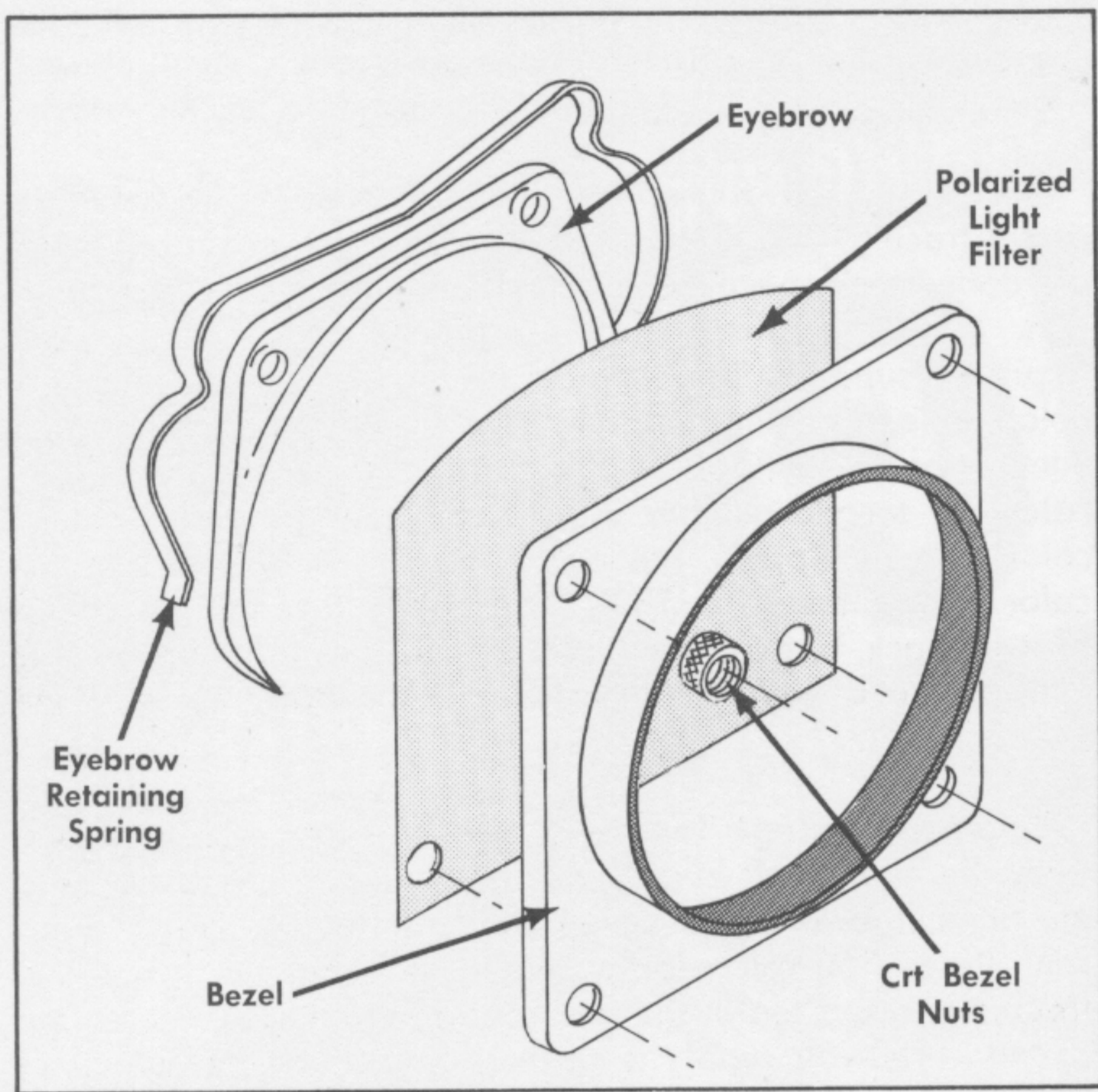

Fig. 4-2. Crt bezel and eyebrow arrangement.

3. Remove crt anode lead, disconnect all leads to the neck of the crt.

NOTE

Do not disconnect the crt trace-rotation coil leads.

4. Using a Phillips screwdriver, loosen the crt base clamp (see Fig. 4-3).
5. With your left hand, wiggle the crt socket (see Fig. 4-3) to ensure that the base of the crt is loose in the base clamp.
6. With a chisel-tipped plastic or wooden dowel, carefully work the crt socket loose from the crt base.
7. Grasp the face of the crt with the right hand. Push the crt carefully towards the front of the Type 546 with the left hand. Be careful not to bend the neck pins. Remove the crt through the front of the oscilloscope.
8. Before reinstalling the crt, dust talcum powder on the crt base. This keeps the base of the crt from sticking to the neoprene bushing inside the base clamp.
9. Carefully insert the new tube into the shield and the tube base clamp. Keep the anode button in line with the anode connector hole so that the button is aligned with the hole when the crt is fully inserted.

NOTE

Make sure that the crt base clamp is loose enough to permit the crt base to slide through the neoprene bushing inside the base clamp.

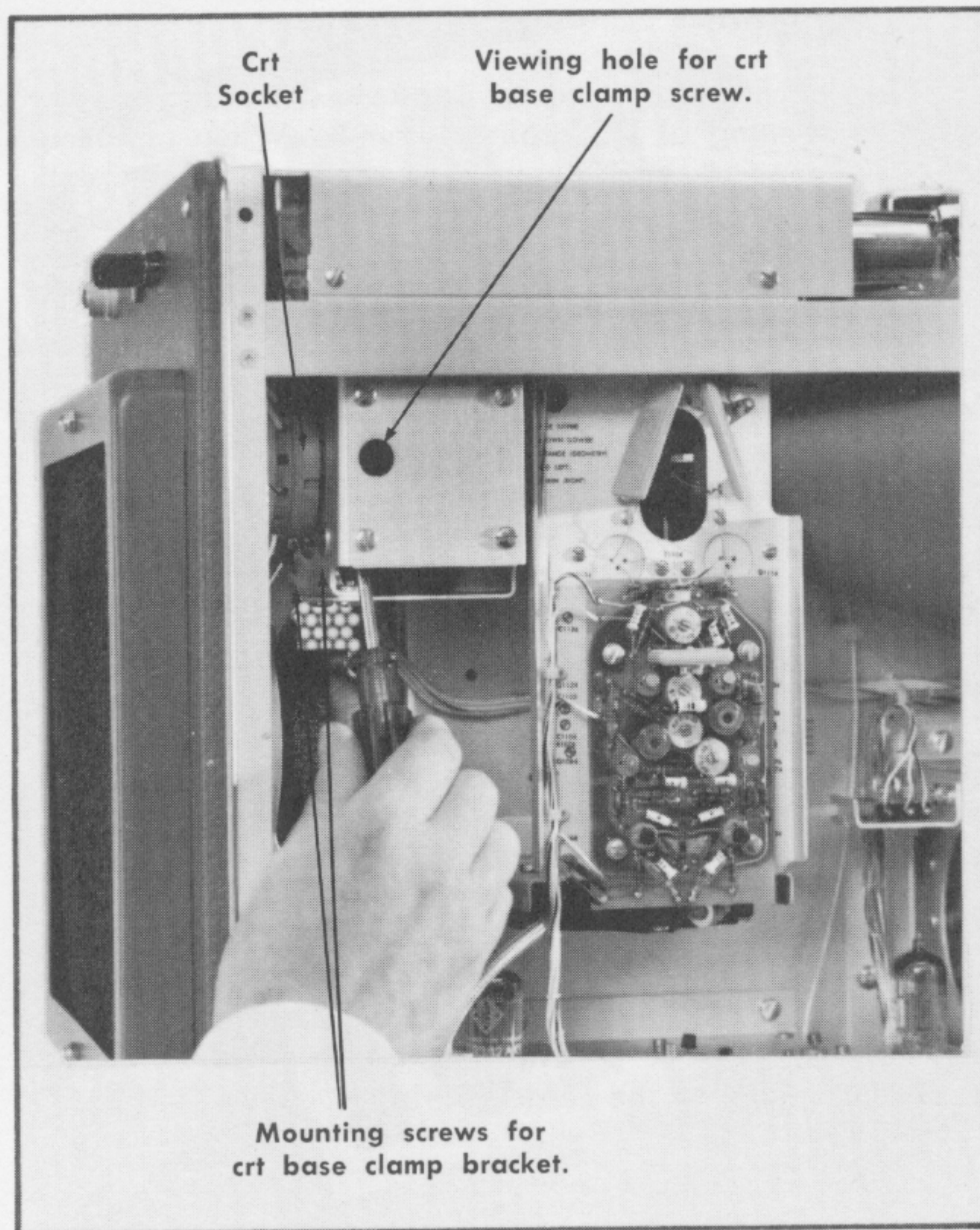

Fig. 4-3. Loosening the crt base clamp.

10. Connect the tube socket to the tube base. Check that the socket is fully seated.
11. Align the crt so that the horizontal graticule lines are parallel with the top of the front panel. Push the crt inward until the crt face protrudes $\frac{3}{16}$ " beyond the front panel.
12. Reconnect the anode and neck-pin leads (observe color code).

NOTE

If the crt face is not parallel with the front of the oscilloscope, use a $\frac{7}{64}$ " hexagonal wrench to loosen the two mounting screws that fasten the base clamp to its mounting bracket (see Fig. 4-3). The base clamp and crt base may now be removed radially to align the face of the crt parallel with the front of the oscilloscope.

13. Tighten the base clamp.
14. Turn on the oscilloscope. Obtain a free-running sweep on the crt.
15. Check the alignment of the trace with the graticule lines. If the trace is not parallel with the graticule lines, align the traces with the TRACE ROTATION control.
16. Replace the eyebrow, eyebrow retaining spring, plastic polarized light filter, crt bezel and bezel nuts.

Graticule Lamps

Proper illumination of the crt graticule depends upon the proper positioning of the graticule lamps. When replacing graticule lamps, slide the lamp and socket in or out until the filament of the lamp is at the middle of the eyebrow thickness.

Ceramic Terminal Strips

To remove a ceramic terminal strip, first unsolder all leads and components connected to it. Use diagonal cutters to cut off one side of each stud holding the strip. This frees the strip, and the remainder of the stud can then be pulled free of the chassis with a pair of pliers. The spacers may come out with the studs; if not, they can be pulled out separately. If they are not damaged, the spacers may be used with the new strip assembly. Ceramic strips are supplied with studs attached, so it is not necessary to salvage the old studs.

After removing a damaged strip and stud assembly, place the spacers into the holes in the chassis and insert the studs into the spacers. Be sure that the studs are completely seated in the spacers. If necessary, use a soft-faced mallet to tap the studs into the spacers. Tap the studs in equal increments to prevent strains on the ceramic strip.

Troubleshooting Techniques

If the instrument is not operating, first check that the power cord is plugged in and that there is power at the socket. Then check that the pilot lamp and tube heaters are lit. If necessary, check the line fuse.

Attempt to isolate the trouble by a quick operational and visual check. Make sure that any apparent trouble is actually due to a malfunction within the instrument and not to improper control settings or to a faulty plug-in unit or probe. Instructions for the operation of the Type 546 and general information concerning plug-in operation are contained in Section 2. Operating instructions for a specific plug-in unit or probe will be found in the manual for that unit.

Check the settings of all controls on the Type 546 and the vertical plug-in preamplifier unit. A control set to the wrong position may cause what appears to be a trouble symptom. Operate the controls to see what effect, if any, they have on the trouble symptom. The normal or abnormal operation of each particular control helps in establishing the nature of the trouble.

When vertical-system troubles are encountered, isolate the trouble to the Type 546 or to the vertical plug-in preamplifier unit. The best way to determine this is by substituting another vertical plug-in preamplifier unit. If the trouble appears to be in the plug-in unit, refer to the Maintenance section of the plug-in unit instruction manual.

If other plug-in units are not available, and the symptoms are not definite, check the power-supply resistances and voltages since a failure in one of the regulated power supplies frequently presents unusual symptoms. Table 5-2 in the Calibration Procedure lists normal resistance to ground for each

power-supply lead. Typical voltages in the power supplies are shown on the power-supply schematic. The voltages shown may vary slightly from instrument to instrument.

All wiring used in the Type 546 is color coded to facilitate circuit tracing. In addition, all regulated power-supply leads are coded with specific color combinations for easy identification. In general, three strips are placed on the wires of the regulated supplies. The code used is the standard EIA number-color code. The first color (widest stripe) indicates the first number of the voltage on that lead. The second color indicates the second number of the lead voltage, and the third color is a multiplier. The method is similar to that used in color coding resistors. Thus, the +100-volt leads are coded brown, black, brown. The voltage is positive if the body color of the wire is white and negative if the body color of the wire is tan.

Reference voltage for the regulated supplies is obtained from the —150-volt supply. If it is not operating properly, the other low-voltage supplies will be affected. For this reason, the —150-volt supply should be checked first when trouble is suspected in the low-voltage supplies. If the output of the —150-volt supply is correct, then check the outputs of the other supplies.

Most troubles that might occur in Tektronix instruments result from the failure of vacuum tubes or semiconductors. Once the trouble has been isolated to a particular area or circuit, check the tubes and semiconductors in the trouble area. It is preferable to check them by substitution rather than with a tester, since testers frequently fail to indicate certain troubles which can affect oscilloscope performance. Remember that when a tube or semiconductor fails, associated circuit components can be damaged.

Circuit Troubleshooting

The Type 546 consists of nine main circuits plus the Calibrator and Alternate-Trace Sync Amplifier circuits. The 9 main circuits are:

1. Low-Voltage Power Supply
2. Crt Circuit (including the High-Voltage Power Supply)
3. Vertical Amplifier and Delay Line
4. Main Time Base (B) Sweep-Trigger Circuit
5. Main Time Base (B) Sweep Generator
6. Time Base A Sweep Trigger Circuit
7. Time Base A Sweep Generator
8. Delay-Pickoff Circuit
9. Horizontal Amplifier

The crt display can often be used to identify a defective circuit. For example, if there is no vertical deflection when the intensity and horizontal deflection appears normal, the trouble can be open signal connections, no signal source, the plug-in unit or even loose crt connections. Other abnormal characteristics in the crt display similarly point to a defective circuit or group of circuits.

Once the nature and approximate location of the trouble has been determined, further isolate the trouble by performing the steps in the calibration procedure for the circuits in which trouble is suspected. The voltages and waveforms to be expected in each circuit are shown on the schematics. Refer to Section 3 for an explanation of the operation of the defective circuit.

IMPORTANT

When it is desired to operate the plug-in unit from a plug-in extension, the plug-in sensing switch (SW673, located at the top rear of the plug-in compartment) must be manually operated. To manually operate the switch, pull the plastic plunger outward to the stop position.

SECTION 5

CALIBRATION

Introduction

The Type 546 Oscilloscope is a stable instrument which will provide many hours of trouble-free operation. However, to insure measurement accuracy, it is suggested that you recalibrate the instrument after each 500 hours of operation or every six months if used intermittently. It will also be necessary to recalibrate certain sections of the instrument when tubes, transistors, or other components are replaced.

The steps in the following procedure are arranged in the proper order for complete recalibration so as to avoid unnecessary repetition.

NOTE

This procedure is a combination performance check and adjustment procedure. The first part of the step title is the name of the check or adjustment and the latter portion refers to the pertinent circuit diagram. Tables 5-4, 5-5, 5-6, 5-8, 5-10, and 5-11 list the front-panel control settings at particular points in the procedure. These tables serve two purposes: (1) To quickly check your own setup, and (2) to enable you to start in the "middle" of the procedure when it is necessary to recalibrate a certain portion of the instrument. For example, Table 5-4 shows the front-panel setup at the completion of step 12e. Using these same control settings this can be the starting point for recalibrating the A Sweep Trigger circuit. Table 5-4 can also be used when determining the setup needed for starting the recalibration of the B Sweep Trigger circuit. There is no need to go back any further towards the beginning of the procedure to find out what the front-panel setup should be.

Unless otherwise stated, all resistances, voltages, and waveforms are measured with respect to chassis ground.

EQUIPMENT REQUIRED

The following equipment or its equivalent, is necessary for complete calibration of the Type 546 Oscilloscope:

- (1) Low-Bandwidth Test Oscilloscope with a 1X attenuator probe.
Description: Bandwidth, dc to 300 kc or better; calibrated vertical deflection factor of 5 mv/cm.
Purpose: To check low-voltage power supply output ripple amplitude.
- (2) Test load unit, Tektronix Type TU-7. Contains a pulse generator capable of producing pulses with a risetime of 3 nsec or faster. This multi-purpose test-load unit is the only plug-in needed to perform a complete calibration of the Type 546 Oscilloscope.
- (3) Time Mark generator, Tektronix Type 180A. Markers required at 1 and 5 seconds; 500, 100, 10, 5, and 1 milliseconds; 500, 100, 50, 10, 5 and 1 microseconds; 5, 10 and 50 megacycle sine waves. 10 μ sec trigger

pulse output required. All outputs must have a time accuracy of at least 0.1 %.

- (4) VOM (Volt-Ohm-Milliammeter) DC sensitivity of at least 20,000 ohms per volt.
Calibrated for an accuracy of at least 1% at -150 , $+100$, $+225$, and $+350$ volts; at least 5% at -1850 volts.
- (5) Variable autotransformer (e.g. Powerstat or Variac). Required specifications: a rating of at least 600 volt-amperes; output voltage range covering the operating range of the oscilloscope under test.
- (6) An rms-calibrated ac voltmeter. Required specifications: a range of 0-150 volts (0-300 volts if the oscilloscope is wired for 230-volt nominal line-voltage operation.
- (7) Two coaxial cables, 50-ohm nominal impedance, 42" long, with BNC plug-connectors on each end. Part No. 012-057.
- (8) Power cord adapter for connecting the 3-wire oscilloscope power cord to a 2-wire receptacle. Part No. 103-013.
- (9) Adapter, single binding post fitted with a BNC plug. Part No. 103-033.
- (10) Coaxial connector adapter with BNC-jack and UHF-plug connector fittings. Part No. 103-015.
- (11) Jumper clip lead, about 4" long. Equipped with miniature alligator clips on each end.
- (12) Two interconnecting leads, 18" long, red, with combination plug-and-jack banana type connectors on each end. Type PC-18R. Part No. 012-031.
- (13) BNC T connector. Fits one BNC jack and accepts two BNC plugs. Part No. 103-032.
- (14) Miscellaneous Items
 - 1—Screwdriver, $\frac{3}{16}$ " wide bit, shank about 3" long.
 - 1—Screwdriver, $\frac{3}{32}$ " wide bit, shank about 2" long.
 - 1—Jaco No. 125 insulated low-capacitance-type screwdriver with a $1\frac{1}{2}$ " long shank and $\frac{1}{8}$ " wide metal tip. Total length is 5". Part No. 003-000.
 - 1—Low-capacitance alignment tools, consisting of a handle (Part No. 003-307), a gray nylon insert with a metal screwdriver tip (Part No. 003-334), a $\frac{5}{64}$ " hexagonal wrench insert (Part No. 003-310).
 - 1—Hexagonal wrench, $\frac{1}{16}$ ". Purpose: To reposition, if necessary, the TRIGGERING LEVEL control knobs.

PRELIMINARY PROCEDURE

1. Remove the side and bottom panels from the oscilloscope.
2. Insert the Type TU-7 (item 2) in the oscilloscope vertical plug-in compartment.

Calibration — Type 546/RM546

3. Set the Type TU-7 Test Function switch to the Low Load position.
4. Lay the oscilloscope on its left side for access to the bottom of the instrument, (and later in the procedure for access to the —150 VOLTS control.
5. Using the VOM, check the resistance at the regulated bus of each power-supply lead to ground at the test points shown in Fig. 5-1. The values of resistances should be approximately as indicated in Table 5-1, once the capacitors are charged by the VOM internal battery.

TABLE 5-1

POWER SUPPLY LEAD	RESISTANCE TO GROUND
—150 volts	1 k to 2 k
+100 volts	1 k to 2 k
+225 volts	2 k to 3 k
+350 volts	Over 40 k

6. Check the fuse at the rear of the instrument for correct value.
7. Connect the instrument and ac voltmeter to the auto-transformer output. Connect the autotransformer to the power line.
8. Turn the INTENSITY control on the instrument fully counterclockwise and turn on the power to all the equipment. Adjust the autotransformer output voltage to 115 volts (or the design-center voltage for which the instrument is wired).
9. Set the oscilloscope front-panel controls to the positions listed in Table 5-2.

TABLE 5-2

CRT Controls	
INTENSITY	0
FOCUS	As is
ASTIGMATISM	As is
SCALE ILLUM	5
Time Base A	
TRIGGERING LEVEL	ccw; knob pushed in
TRIGGERING—	
MODE	TRIG
SLOPE	+
COUPLING	AC
SOURCE	NORM INT
VARIABLE (TIME/CM)	CALIBRATED
TIME/CM	.5 mSEC
Horizontal Display	
HORIZONTAL DISPLAY	A
SWEEP MAGNIFIER	X1 OFF
SINGLE SWEEP SWITCH	NORMAL

Main Time Base (B)	
TRIGGERING LEVEL	ccw; knob pushed in
TRIGGERING—	
MODE	TRIG
SLOPE	+
COUPLING	AC
SOURCE	NORM INT
VARIABLE (TIME/CM)	CALIBRATED
TIME/CM	.5 mSEC
BRIGHTNESS	Fully clockwise

Other Controls

DELAY-TIME MULTIPLIER	1.00
HORIZONTAL POSITION	Midrange
VERNIER (HORIZONTAL POSITION)	Midrange
AMPLITUDE CALIBRATOR	OFF

10. Set the Type TU-7 front-panel controls to these settings:

Vertical Position	Centered
Test Function	Low Load
Other Controls	As is
11. Allow about five minutes warm-up time. Check that the EXT CRT CATHODE-to-GND shorting strap is in place on the terminals and the CRT CATHODE SELECTOR switch is at EXTERNAL CRT CATHODE position.
12. Recheck the autotransformer output for proper design center voltage as soon as the instrument is warmed up.

CALIBRATION PROCEDURE

1. Check Voltage Accuracy—Power Supply

(If necessary, adjust —150 VOLTS R616)

- a. Establish the conditions given in the Preliminary Procedure.
- b. Check that the oscilloscope is placed on its left side for access to the bottom and right side of the instrument.
- c. Check the voltage accuracy of each power supply output using the VOM (item 4) according to the information given in Table 5-3. The location of the test points is shown in Fig. 5-1.

TABLE 5-3

Power Supply	Tolerance	Maximum Peak-to-Peak Ripple
—150 v	—147 to —153	10 mv
+100 v	+98 to +102	15 mv
+225 v	+220.5 to +229.5	10 mv
+350 v	+343 to +357	25 mv

- d. If necessary, adjust to —150 VOLTS R616 control (see Fig. 5-2) so all power supply voltages are within tolerance.

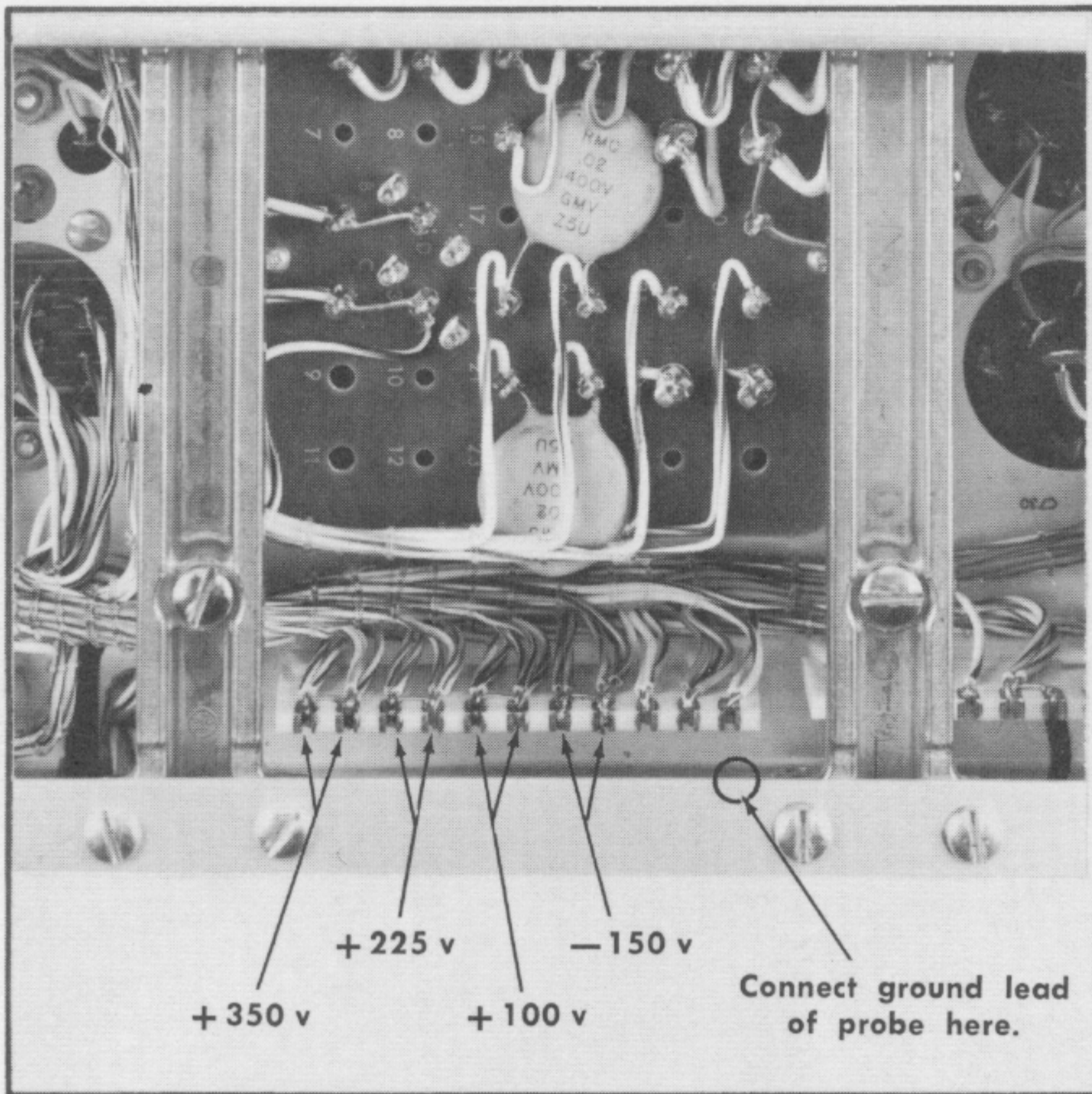

Fig. 5-1. Low-voltage power supply test point locations (bottom of instrument near power transformer).

NOTE

Don't adjust the —150 VOLTS control unless one or more of the supplies is actually out of tolerance. Remember that the calibration of the entire instrument is affected by changes in the power supply voltages. All the positive voltage power supplies depend upon the —150-volt supply measurement accuracy.

2. Check Regulation and Output Ripple—Power Supply

NOTE

When checking for proper regulation of the power supplies at the lower line voltage limit, the ac line voltage should contain no more than 3% distortion.

- a. Monitor the regulated output of the —150-volt supply with the VOM. The test point location is shown in Fig. 5-1.
- b. Connect a 1X probe from a test oscilloscope (item 1) to the —150-volt test point and check the output ripple amplitude. The maximum ripple voltage is given in Table 5-3.

NOTE

Ground loops can cause an erroneous ripple measurement. (Ripple due to ground loops is the same frequency as the line; low-voltage power supply ripple is twice the line rate.) One way to avoid ripple due to ground loops is to temporarily disconnect the chassis ground wire in the power cord by using an ungrounded 3- to 2-wire line plug adapter. Then use a ground lead from the

signal probe body to make a ground connection to the oscilloscope chassis at the location shown in Fig. 5-1. The probe will then provide the only ground connection between the two instruments. The term "test oscilloscope" is item 1 while the term "oscilloscope" or "instrument" is the oscilloscope being calibrated.

- c. Slowly increase the output of the variable autotransformer to 126.5 vac (or 10% above the design-center line voltage for which the instrument is wired). The dc output voltage should remain essentially constant; typically within 2% of that obtained with design-center line voltage. The ripple voltage should not exceed the maximum peak-to-peak amplitude given in Table 5-3.
- d. Repeat steps 2a through 2c for each supply.
- e. Reset the autotransformer for 115 volts output (or design-center voltage for which the instrument is wired).
- f. Set the Type TU-7 Test Function Load switch to High Load.
- g. Reduce the line voltage to 103.5 volts (or 10% below design-center voltage). The dc output voltage of each supply should remain essentially constant; typically within 2% of that obtained at design-center voltage. Ripple voltage should not exceed the maximum peak-to-peak amplitude given in Table 5-3.
- h. Disconnect the VOM and X1 Probe.
- i. Reset the autotransformer for 115 volts output (or design-center).
- j. Set the Type TU-7 Test Function switch to Low Load.
- k. Place the instrument in its upright position.
- l. If the 3-to-2 line-plug adapter was used during this step, turn off the oscilloscope power and remove the adapter. Plug the line cord directly into the autotransformer and turn on the oscilloscope power.

3. Adjust HIGH VOLTAGE R840—Crt Circuit

- a. Set the scale of the VOM to measure —1850 volts and connect the VOM between the high-voltage test point (see Fig. 5-3) and ground.
- b. Adjust the HIGH VOLTAGE control R340 (see Fig. 5-2) for a —1850 volt meter indication.

4. Check High Voltage Regulation—Crt Circuit

- a. With the VOM connected to the high voltage test point, use the meter to monitor the voltage at this point.
- b. Set the A TRIGGERING MODE switch to AUTO.
- c. Rotate the INTENSITY control clockwise until the trace is at normal intensity. Use the Type TU-7 Vertical Position control to vertically center the trace. Defocus the trace with the FOCUS and ASTIGMATISM control. Set the INTENSITY control at 7.

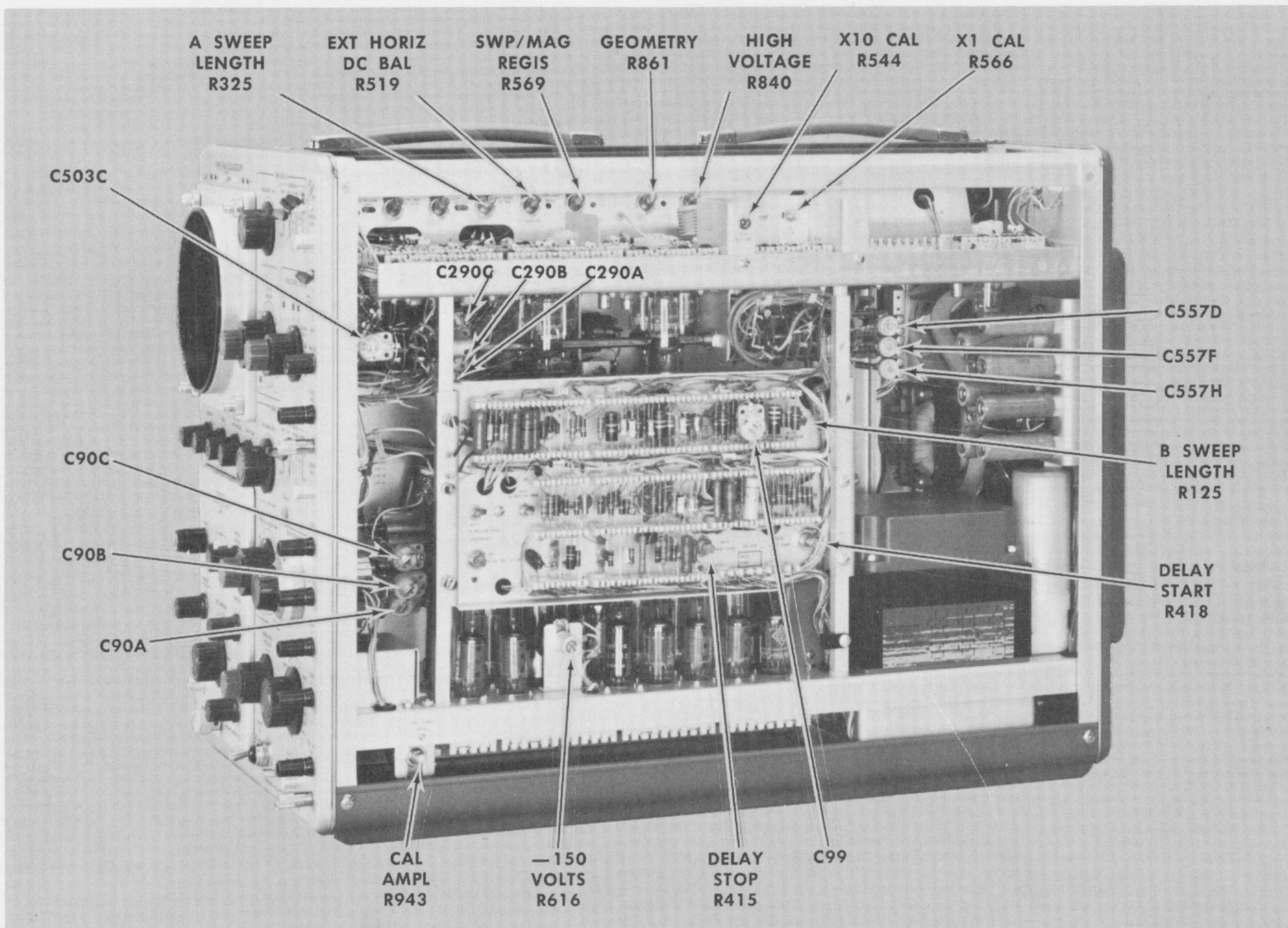

Fig. 5-2. Calibration adjustment location (right side view).

- d. Use the HORIZONTAL POSITION control to position the trace to start at the left side of the graticule.
- e. Slowly increase the output of the variable autotransformer to 126.5 vac (or 10% above the design-center line-voltage for which the instrument is wired). The high voltage dc output should remain essentially constant; typically within 2% of that obtained with design-center line voltage. The trace should not show any signs of blooming. (Blooming is when the display changes size as the supply voltage changes.)
- f. Reset the autotransformer for 115 volts output (or design-center voltage for which the instrument is wired).
- g. Set the Type TU-7 Test Function switch to High Load.
- h. Reduce the line voltage to 103.5 volts (or 10% below design-center voltage). The high voltage dc output should remain constant; typically within 2% of that obtained with design-center line voltage. The trace should not show any signs of blooming.
- i. Reset the autotransformer for 115 volts output (or design-center).
- j. Set the Type TU-7 Test Function switch to Low Load.

- k. Decrease the trace intensity to normal with the INTENSITY control.
- l. Disconnect the VOM.

5. Adjust CAL AMPL (Calibrator Amplitude)—R943—Calibrator

- a. Connect a single binding post adapter (item 9) to the oscilloscope CAL OUT connector.
- b. Connect the VOM to the binding post adapter and to the oscilloscope chassis.
- c. Set the AMPLITUDE CALIBRATOR switch to 100 V DC.
- d. Adjust the CAL AMPL control R943 (see Fig. 5-2) for a voltmeter reading of exactly 100 volts.

6. Check Duty Factor of Signal—Calibrator

- a. Set the AMUPLITUDE CALIBRATOR switch to 100 VOLTS (not 100 V DC).
- b. Check for a voltmeter reading of +45 to +55 volts as measured between the CAL OUT connector and ground.

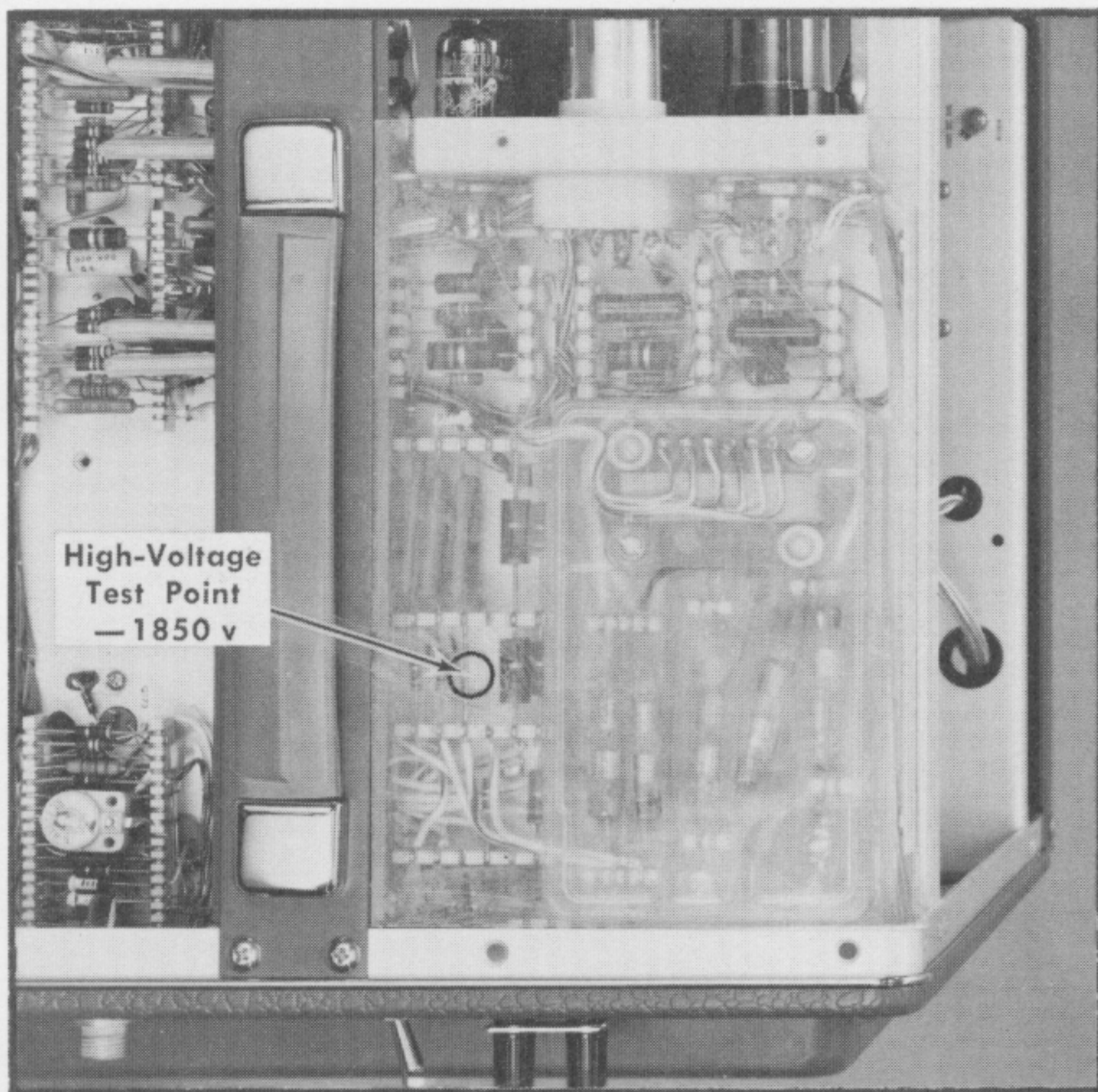

Fig. 5-3. High-voltage test point location (top left rear view).

NOTE

+50 volts indicates a nominal duty factor of 0.5. If the voltage is not within +45 to +55 volts try new tubes.

- c. Disconnect the VOM and set the AMPLITUDE CALIBRATOR switch to OFF.
- d. Remove the adapter from the CAL OUT connector.

7. Adjust TRACE ROTATION—Crt Circuit

- a. Adjust the FOCUS and ASTIGMATISM controls for narrowest trace.
- b. Position the trace directly behind the center horizontal graticule line, using the Type TU-7 Vertical Position control.
- c. If the trace and graticule line do not coincide over the width of the graticule, adjust the TRACE ROTATION control for correct trace alignment.

8. Adjust GEOMETRY R861—Crt Circuit

- a. Apply 50 μ sec markers from the time-mark generator through a coaxial cable to the Type TU-7 Ext Input connector.
- b. Set the A TIME/CM switch to 50 μ SEC.
- c. Advance the INTENSITY control to make the display visible.
- d. Set the TRIGGERING LEVEL control to obtain a stable display of vertical marker lines.

- e. Adjust the TU-7 Variable control so the markers overscan the crt; set the Vertical Position control to position the base line of the markers below the display area.
- f. Use the HORIZONTAL POSITION control to position the markers so they align with the graticule markings.
- g. Adjust the GEOMETRY control R861 (see Fig. 5-2) for straightest possible vertical marker-lines running parallel to the 0-cm and 10-cm graticule. Note the amount of bowing.
- h. Disconnect the signal from the TU-7 Ext Input connector.
- i. Reduce the trace intensity to normal with the INTENSITY control while positioning the trace onto the crt with the TU-7 Vertical Position control.
- j. Using the TU-7 Vertical Position control, position the trace to the bottom of the graticule. Note the amount of bowing. Then position the trace to the top of the graticule and note the amount of bowing.
- k. Repeat steps 8a through 8j so the trace exhibits minimum bowing in both planes.
- l. After completing the previous steps, disconnect the signal from the TU-7 Ext Input connector. Check that the trace is positioned into the display area and the INTENSITY control is set to a suitable trace brightness level.

9. Adjust VERT DC BAL (Vertical Amplifier Dc Balance) R1004—Vertical Amplifier

- a. Using a small screwdriver, short the crt vertical deflection plate pins together (see Fig. 5-4).

CAUTION

Do not short the crt deflection plate pins to ground.

- b. Note the position of the trace. This is the electrical center of the crt vertical deflection plates.
- c. Remove the screwdriver from the crt pins.
- d. Short the cases of Q1104 and Q1124 (see Fig. 5-4) together (not to ground) and note the deviation of the trace from electrical center. Deviation should not be more than 0.5 cm maximum. Remove the short.
- e. Short the casts of Q-1074 and Q1084 together (see Fig. 5-4) and note the trace deviation from electrical center. Deviation should not be more than 0.5 cm maximum. Remove the short.
- f. Short the collector of Q1034 to the collector of Q1044 (see Fig. 5-4) and note the trace deviation from electrical center. Deviation should not be more than 0.5 cm maximum. Remove the short.

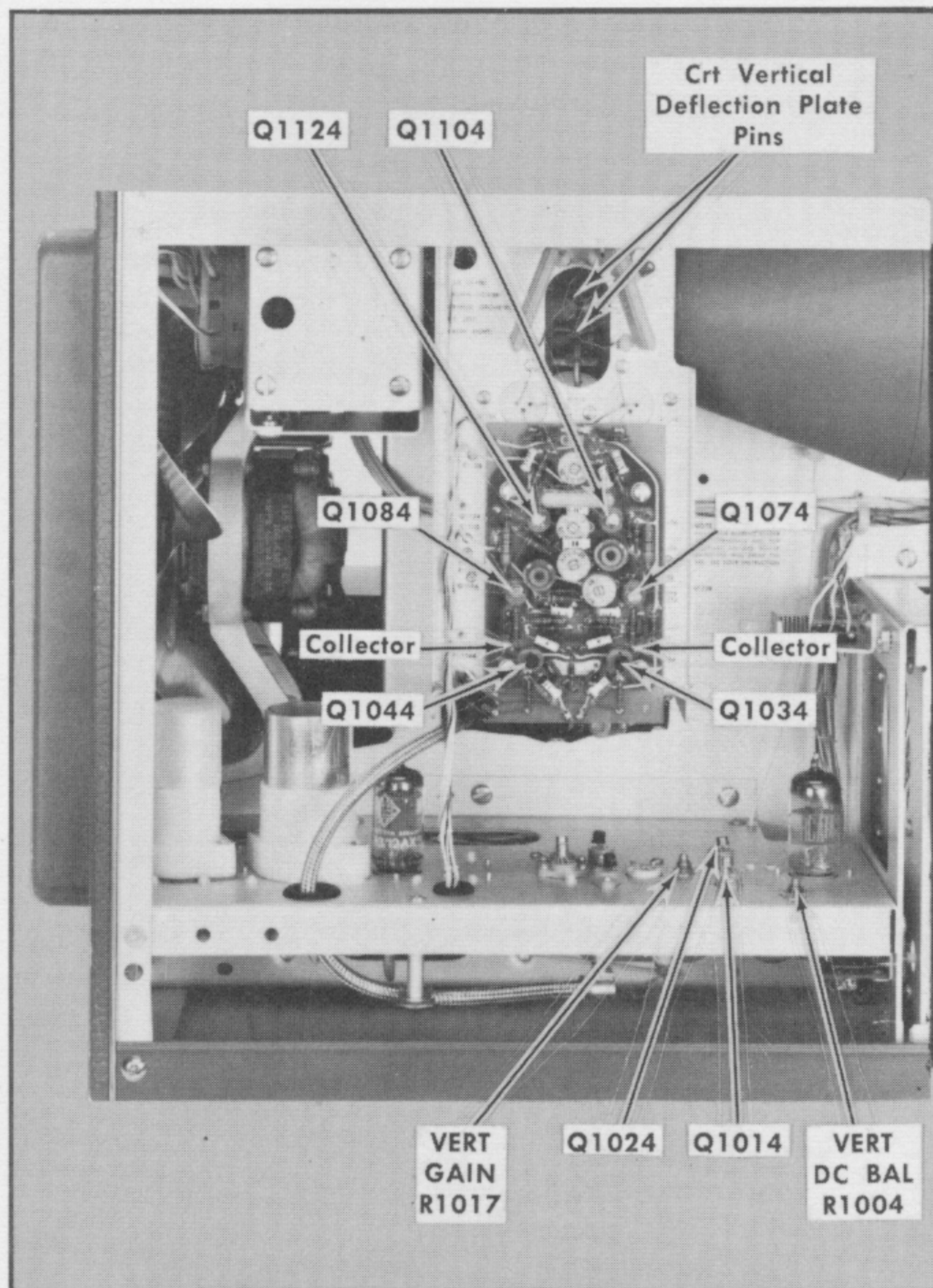

Fig. 5-4. Vertical Amplifier test point and adjustment locations for performing steps 9 and 10.

- f. Short the collector of Q1034 to the collector of Q1044 (see Fig. 5-4) and note the trace deviation from electrical center. Deviation should not be more than 0.5 cm maximum. Remove the short.
- g. Short the cases of Q1014 and Q1024 together (see Fig. 5-4) and note the trace deviation from electrical center. Deviation should not be more than 0.5 cm maximum. Remove the short.
- h. Set the Type TU-7 Test Function switch to Common Mode.
- i. Adjust the VERT DC BAL control R1004 (see Fig. 5-4) to position the trace to the center of the graticule.

10. Adjust VERT GAIN (Vertical Amplifier Gain) R1017—Vertical Amplifier

- a. Set the Type TU-7 Test Function switch to the Gain Set position.
- b. Connect a coaxial cable between the Type TU-7 Ext Input connector and the oscilloscope CAL OUT connector.
- c. Set the AMPLITUDE CALIBRATOR switch to 100 VOLTS.

- d. Pull the 'A' TRIGGERING LEVEL control outward for X10 range increase and rotate the control fully clockwise to free run the time base.
- e. Adjust the VERT GAIN control R1017 (see Fig. 5-4) so the display vertical deflection is exactly four centimeters in amplitude.

11. Check Common-Mode Rejection—Vertical Amplifier

- a. Set the AMPLITUDE CALIBRATOR switch to 1 VOLT.
- b. Set the TU-7 Test Function switch to Common Mode.
- c. Set the A TIME/CM switch to .5 mSEC.
- d. Note the amplitude of the calibrator waveform. The amplitude of the waveform should not be more than 3 mm maximum.

12. Adjust A TRIGGER LEVEL CENTERING R225 and A TRIGGER SENS (A Trigger Sensitivity) R245—Coarse Adjustment—A Sweep Trigger

- a. Set the AMPLITUDE CALIBRATOR switch to OFF.
- b. Insert a BNC T connector (item 13) between the AMPLITUDE CALIBRATOR connector and the coax cable.
- c. Connect another coaxial cable from the 'T' connector to the A TRIG INPUT connector. (The CAL OUT connector should now be connected to the Ext Input connector on the Type TU-7 and to the A TRIGGER INPUT connector on the oscilloscope.)
- d. Set the TU-7 front-panel controls as follows:

VARIABLE	Fully cw
POSITION	Centered
TEST FUNCTION	Low Load
- e. Set the A MODE switch to TRIG, and the A TRIGGERING LEVEL control to 0 (knob pulled out). Check that the A COUPLING switch is set to AC and the A SOURCE switch is set to NORM. (Table 5-4 lists the remaining front-panel control settings up to this point in the procedure.)

TABLE 5-4

CRT Controls	
INTENSITY	≈3.5
FOCUS	≈5
ASTIGMATISM	≈5
SCALE ILLUM	≈9
Time Base A	
TRIGGERING LEVEL Knob	Pulled out
TRIGGERING—SLOPE	+
VARIABLE (TIME/CM)	CALIBRATED
TIME/CM	.5 mSEC

Horizontal Display	
HORIZONTAL DISPLAY	A
SWEEP MAGNIFIER	X1 OFF
Single Sweep Switch	NORMAL
Main Time Base (B)	
TRIGGERING LEVEL	ccw; knob pushed in
TRIGGERING—	
MODE	TRIG
SLOPE	+
COUPLING	AC
SOURCE	NORM
VARIABLE (TIME/CM)	CALIBRATED
TIME/CM	.5 mSEC
BRIGHTNESS	Fully cw
Other Controls	
DELAY-TIME MULTIPLIER	1.00
HORIZONTAL POSITION	about -10° from center
VERNIER (HORIZONTAL POSITION)	Midrange

f. Locate the junction of R217, C218, and R218 (see Fig. 5-5). Connect a short jumper clip lead (item 11) between the junction and ground. This jumper disables the A TRIGGERING LEVEL control.

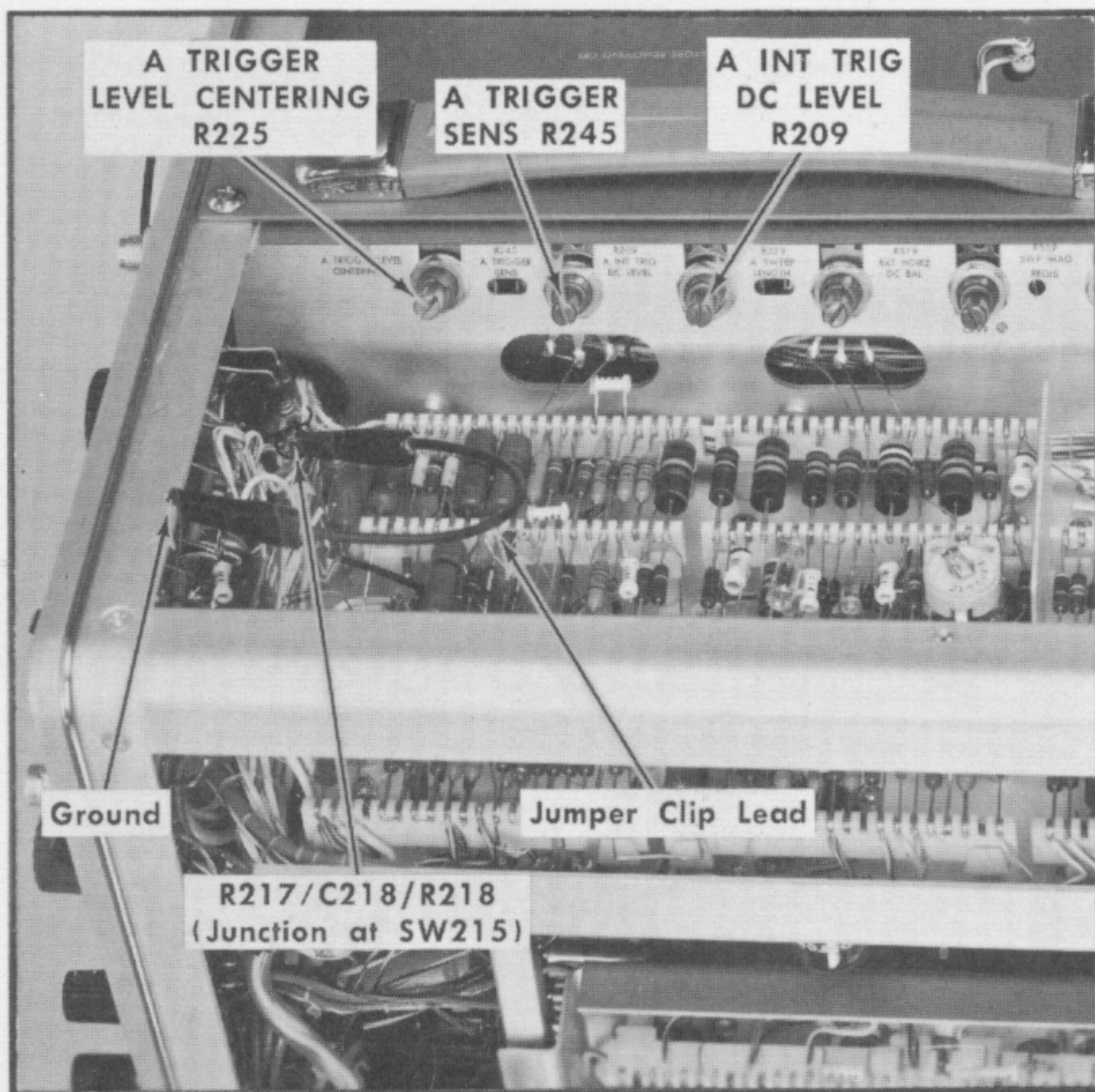

Fig. 5-5. A Trigger clip-lead connection, adjustment and test point locations (upper right corner view).

- g. Rotate the A TRIGGER LEVEL CENTERING R225 and A TRIG SENS R245 controls (see Fig. 5-5) fully clockwise.
- h. Rotate the A TRIGGER LEVEL CENTERING R225 control slowly counterclockwise until a steady trace

appears. Do not turn the control any further counterclockwise than the point where the steady bright trace was first obtained.

NOTE

If a steady trace appears regardless of the setting of the A TRIGGER LEVEL CENTERING R225 control, rotate the A TRIG SENS R245 control a few degrees counterclockwise. Next, return the A TRIGGER LEVEL CENTERING R225 control to its fully clockwise position and repeat step (h).

13. Adjust A TRIGGER LEVEL CENTERING R225 and A TRIGGER SENS R245—Fine Adjustment—A Sweep Trigger

- a. Set the AMPLITUDE CALIBRATOR switch to 50 mVOLTS.

NOTE

A 50-mv peak-to-peak signal is used in this portion of the procedure as an adjustment aid only and is not intended to be interpreted as a trigger-amplitude specification.

- b. Set the A SOURCE switch to EXT.
- c. Rotate the A TRIGGER SENS R245 control counterclockwise until the displayed waveform disappears. Then rotate the control slightly clockwise until the waveform reappears. Do not turn the control any further clockwise from this point.
- d. Rotate the A TRIGGER LEVEL CENTERING R225 control slowly clockwise until the waveform disappears and then rotate the control counterclockwise until the waveform reappears. Continue rotating the control in a counterclockwise direction until the waveform disappears. Note the range of movement that the A TRIGGER LEVEL CENTERING R225 control was moved while obtaining a display.
- e. Set the A TRIGGER LEVEL CENTERING R225 control in the center of the range noted in the previous step.
- f. Slowly rotate the A TRIGGER SENS R245 control counterclockwise until the displayed waveform disappears. Then turn the control slightly clockwise until a point is reached where the waveform reappears. Do not turn the control any further clockwise from this point.
- g. Repeat steps d through f to reduce the range of movement of the A TRIGGER LEVEL CENTERING R225 control, noted in step d, as narrow as possible while keeping the waveform displayed. Also, the A TRIGGER SENS R245 control must be adjusted to a counterclockwise point where, as a final result, a display is barely obtained. That is, the waveform does not necessarily have to be stable; a flickering display can also be an indication when optimum results are obtained.

NOTE

One fast method for reaching optimum results is to let the waveform disappear as described in the first statement of step f. Then, use the A TRIGGER LEVEL CENTERING R225 control to make the waveform reappear. Alternate between the two controls (R225 and R245) until optimum adjustment of both controls is reached while still displaying a waveform.

14. Adjust A INT TRIG DC LEVEL (A Internal Trigger DC Level) R209—A Sweep Trigger

- Set the AMPLITUDE CALIBRATOR switch to .5 VOLTS.
- Set the A SOURCE switch to NORM INT.
- Adjust the TU-7 Variable control so the displayed waveform is 5 mm peak-to-peak in amplitude.
- Using the TU-7 Vertical Position control, center the display for equal amplitude above and below the center graticule line.
- Set the A COUPLING switch to DC.
- Adjust the A INT TRIG DC LEVEL R209 control (see Fig. 5-5) to obtain a stable display. (With the 'A' SLOPE switch set to +, the sweep trace should start on the positive-going rise of the calibrator waveform.)

15. Check Internal Triggering—A Sweep Trigger

- Set the A COUPLING switch to AC.
- Adjust the TU-7 Variable control until the display is 2 mm peak-to-peak in amplitude.
- Disconnect the jumper clip lead.
- Adjust the A TRIGGERING LEVEL control to obtain a stable display.
- Operate the A SLOPE switch. Check for stable time-base triggering on the —slope when the SLOPE switch is set to — and stable triggering on the +slope when the SLOPE switch is set to +. If necessary, readjust the A TRIGGERING LEVEL control to obtain a stable display when making the check for each SLOPE switch position.

16. Check A TRIGGERING LEVEL Control Zero Set—A Sweep Trigger

- Check that the A TRIGGERING LEVEL control is set to 0 and the SLOPE switch is set to +.
- Connect the VOM between the R217/C218/R218 junction and ground.
- Carefully rotate the A TRIGGERING LEVEL control to obtain a reading of exactly zero volts on the VOM.
- If the A TRIGGERING LEVEL knob is set properly on the control shaft, the white dot on the knob should be directly below the 0 on the front panel. If the

white dot does not point accurately to 0, disconnect the VOM, loosen the setscrew in the knob and reposition the knob.

- After tightening the knob, set the knob to 0, reconnect the VOM, and recheck the reading. The VOM reading should be zero when the A TRIGGERING LEVEL knob is set to 0.

NOTE

A dc-coupled test oscilloscope with a 10X probe can be used in place of the VOM to perform this step, if desired. As another method, the white dot on the A TRIGGERING LEVEL knob should point to 0 to obtain stable triggering when operating the A SLOPE switch as directed in step 15.

- Disconnect the VOM or 10X probe, whichever one is used.

17. Adjust B TRIGGER LEVEL CENTERING R25 and B TRIGGER SENS (B Trigger Sensitivity) R45—Coarse Adjustment—B Sweep Trigger

- Set the AMPLITUDE CALIBRATOR switch to OFF.
- Disconnect the coaxial cable end from the A TRIGGER INPUT connector and connect it to the B TRIGGER INPUT connector.
- Set the HORIZONTAL DISPLAY switch to B.
- Pull the B TRIGGERING LEVEL knob outward and set the control to 0. Check that the B MODE switch is set to TRIG and the B SOURCE switch is set to NORM INT.

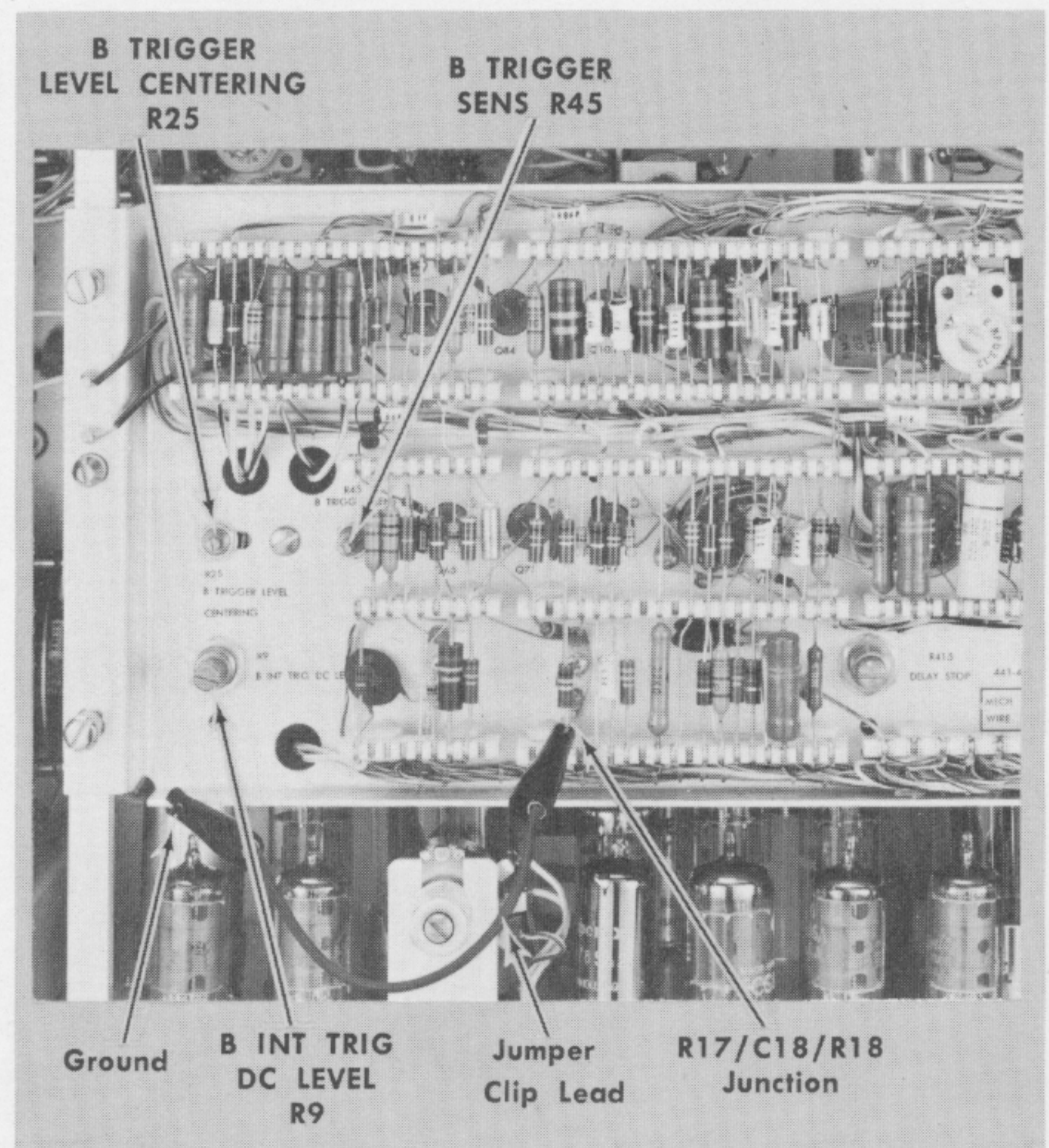

Fig. 5-6. B Trigger clip-lead connections, adjustment and test point locations (right side view).

- e. Locate the junction of R17, C18 and R18 (see Fig. 5-6). Connect a short jumper clip lead between the junction and ground. This jumper disables the 'B' TRIGGERING LEVEL control.
- g. Rotate the B TRIGGER LEVEL CENTERING R25 control slowly counterclockwise until a steady trace appears. Do not turn the control any further counterclockwise than the point where the steady bright trace was first obtained.

NOTE

If a steady trace appears regardless of the setting of the B TRIGGER LEVEL CENTERING R25 control, rotate the B TRIG SENS R45 control a few degrees counterclockwise. Next return the B TRIGGER LEVEL CENTERING R25 control to its fully clockwise position and repeat step (g).

18. Adjust B TRIGGER LEVEL CENTERING R25 and B TRIGGER SENS R45—Find Adjustment—B Sweep Trigger

- a. Set the AMPLITUDE CALIBRATOR switch to 50 mVOLTS.

NOTE

A 50-mv peak-to-peak signal is used in this portion of the procedure as an adjustment aid only and is not intended to be interpreted as a trigger-amplitude specification.

- b. Set the B SOURCE switch to EXT and the TU-7 Variable control fully clockwise.
- c. Rotate the B TRIGGER SENS R45 control counterclockwise until the displayed waveform disappears. Then rotate the control slightly clockwise until the waveform reappears. Do not turn the control any further clockwise from this point.
- d. Rotate the B TRIGGER LEVEL CENTERING R25 control slowly clockwise until the waveform disappears and then rotate the control counterclockwise until the waveform reappears. Continue rotating the control in a counterclockwise direction until the waveform disappears. Note the range of movement that the B TRIGGER LEVEL CENTERING R25 control was moved while obtaining a display.
- e. Set the B TRIGGER LEVEL CENTERING R25 control in the center of the range noted in the previous step.
- f. Slowly rotate the B TRIGGER SENS R45 control counterclockwise until the displayed waveform disappears. Then turn the control slightly clockwise until a point is reached where the waveform reappears. Do not turn the control any further clockwise from this point.
- g. Repeat steps d through f to reduce the range of movement of the B TRIGGER LEVEL CENTERING R25 control, noted in step d, as narrow as possible while keeping the waveform displayed. Also, the B TRIGGER SENS R45 control must be adjusted to a counterclockwise point where, as a final result, a display

is barely obtained. That is, the waveform does not necessarily have to be stable; a flickering display can also be an indication that optimum results are obtained.

NOTE

One fast method for reaching optimum results is to let the waveform disappear as described in the first statement of step f. Then, use the B TRIGGER LEVEL CENTERING R25 control to make the waveform reappear. Alternate between the two controls (R25 and R45) until optimum adjustment of both controls is reached while still displaying the waveform.

19. Adjust B INT TRIG DC LEVEL (B Internal Trigger DC Level) R9—B Sweep Trigger

- a. Set the AMPLITUDE CALIBRATOR switch to .5 VOLTS.
- b. Set the B SOURCE switch to NORM INT.
- c. Adjust the TU-7 Variable control so the displayed waveform is 5 mm peak-to-peak in amplitude.
- d. Using the TU-7 Vertical Position control, center the display for equal amplitude above and below the center graticule line.
- e. Set the B COUPLING switch to DC.
- f. Adjust the B INT TRIG DC LEVEL R9 control (see Fig. 5-6) to obtain a stable display. (With the B SLOPE switch set to +, the sweep trace should start on the positive-going rise of the calibrator waveform.)

20. Check Internal Triggering—B Sweep Trigger

- a. Set the B COUPLING switch to AC.
- b. Adjust the TU-7 Variable control until the display is 2 mm peak-to-peak in amplitude.
- c. Disconnect the jumper clip lead.
- d. Adjust the B TRIGGERING LEVEL control to obtain a stable display.
- e. Operate the B SLOPE switch. Check for stable time-base triggering on the —slope when the SLOPE switch is set to — and stable triggering on the +slope when the SLOPE switch is set to +. If necessary, readjust B TRIGGERING LEVEL control to obtain a stable display when making the check for each SLOPE switch position.

21. Check B TRIGGERING LEVEL Control Zero Set—B Sweep Trigger

- a. Check that the B TRIGGERING LEVEL control is set to 0 and the SLOPE switch is set to +.
- b. Connect the VOM between R17/C18/R18 junction and ground.
- c. Carefully rotate the B TRIGGERING LEVEL control to obtain a reading of exactly zero volts on the VOM.

Calibration — Type 546/RM546

- d. If the B TRIGGERING LEVEL knob is set properly on the control shaft, the white dot on the knob should be directly below the 0 on the front panel. If the white dot does not point accurately to 0, disconnect the VOM, loosen the setscrew in the knob and reposition the knob.
- e. After tightening the knob, set the knob to 0, reconnect the VOM, and recheck the reading. The VOM reading should be zero when the B TRIGGERING knob is set to 0.

NOTE

A dc-coupled test oscilloscope with a 10X probe can be used in place of the VOM to perform this step. As another method the white dot on the B TRIGGERING LEVEL knob should point to 0 to obtain stable triggering when operating the B SLOPE switch as directed in step 20.

- f. Disconnect the VOM or 10X probe, whichever one is used.
- h. Disconnect the coax cables, 'T' connector, and set the AMPLITUDE CALIBRATOR switch to OFF.

22. Adjust SWP/MAG REGIS (Sweep/Magnifier Registration) R569—Horizontal Amplifier

- a. Set the Main Time Base (B) Front-panel controls to these settings:

TRIGGERING LEVEL	About 25° clockwise from 0
MODE	AUTO
SLOPE	+
COUPLING	AC
SOURCE	NORM INT
TIME/CM	1 mSEC

(All the remaining front-panel control settings up to this point in the procedure are listed in Table 5-5.)

TABLE 5-5

CRT Controls	
INTENSITY	≈3.7
FOCUS	≈5
ASTIGMATISM	≈5
SCALE ILLUM	≈8
Time Base A	
TRIGGERING LEVEL	0; knob pulled outward
TRIGGERING—	
MODE	TRIG
SLOPE	+
COUPLING	AC
SOURCE	NORM INT
VARIABLE (TIME/CM)	CALIBRATED
TIME/CM	.5 mSEC

Horizontal Display

HORIZONTAL DISPLAY	B
SWEEP MAGNIFIER	X1 OFF
Single Sweep Switch	NORMAL

Main Time Base (B)

TRIGGERING LEVEL	Knob pulled outward
VARIABLE (TIME/CM)	CALIBRATED
BRIGHTNESS	Fully cw

Other Controls

DELAY-TIME MULTIPLIER	1.00
HORIZONTAL POSITION	Approximately centered
VERNIER (HORIZONTAL POSITION)	Centered
AMPLITUDE CALIBRATOR	OFF

Type TU-7

Vertical Position	Centered
Variable	≈3
Test Function	Low Load

- b. Apply 100- μ sec, 1 msec and 5-msec time markers from the time-mark generator through a coaxial cable to the TU-7 Ext Input connector.
- c. Set the TU-7 Variable control so the display is about 4 centimeters in amplitude.

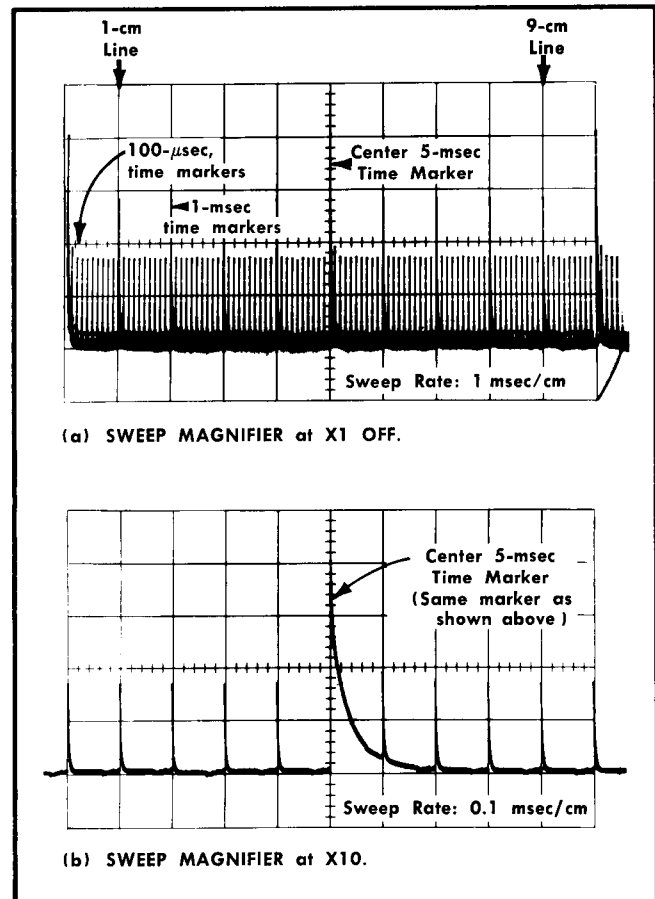

Fig. 5-7. Time marker displays.

- d. Center the display vertically using the TU-7 Vertical Position control.
- e. Adjust, if necessary, the B TRIGGERING LEVEL control to obtain stable triggering on the 5-msec time marks. Fig. 5-7a shows the time markers displayed with respect to the graticule markings. Use the HORIZONTAL POSITION control to position the center 5-msec time marker to the center of the graticule as shown in the illustration.
- f. Set the SWEEP MAGNIFIER switch to X10. Position the 5-msec time marker to graticule center (see Fig. 5-7b) and then set the SWEEP MAGNIFIER switch to X1 OFF.
- g. Adjust the SWP/MAG REGIS R569 control (see Fig. 5-2) to position the center 5-msec time marker to graticule center. If necessary, repeat steps 22f and 22g until there is no movement of the 5-msec time marker as the SWEEP MAGNIFIER switch is changed from X10 to X1 OFF.

23. Adjust X10 CAL (X10 Magnified Sweep Calibration) R544—Horizontal Amplifier

- a. Set the SWEEP MAGNIFIER switch to X10.
- b. Adjust the X10 CAL R544 control (see Fig. 5-2) so there is 1 marker per cm from the 1-cm to 9-cm graticule lines. For accurate adjustment the X10 CAL control should be adjusted so the markers at the 1- and 9-cm graticule lines coincide exactly with the 1-cm and 9-cm graticule lines.

NOTE

The following hints should help you to obtain the best results in checking and adjusting the time-base sweep rates:

It is quite difficult to detect small sweep rate errors on the order of 1 or 2% unless measurement is made using most of the graticule width. **It is therefore recommended that the sweep rates be checked for correct linearity and timing using the center 8 cm and the middle 80% of the display as shown in Fig. 5-8.** With the measurement taken over a distance of 8 cm, the adjustment can be made more accurately. Further on in the procedure when you check the non-adjustable sweep rates without using the DELAY-TIME MULTIPLIER control a 1.6 mm error would indicate a 2% sweep-rate error as shown in Fig. 5-8. The marker peak provides an excellent reference point, particularly if the amplitude is such that the base line is below the crt viewing area and the tips of the markers are located in the center of the crt. When using the sine waves for markers at the higher sweep rates, set the TU-7 Variable and Vertical Position Controls so the lower half of the display is positioned below the crt and the tips of each cycle are near the center of the crt. By increasing the amplitude of the display in this manner each marker or cycle tip appears much narrower.

The adjustable sweep rates should be set for maximum accuracy. When adjusting the timing capaci-

tors, use a screwdriver having a metal tip and a non-metallic shank to minimize capacitance disturbance to the circuit. This will also lessen the chance of accidentally grounding connections elevated above or below ground.

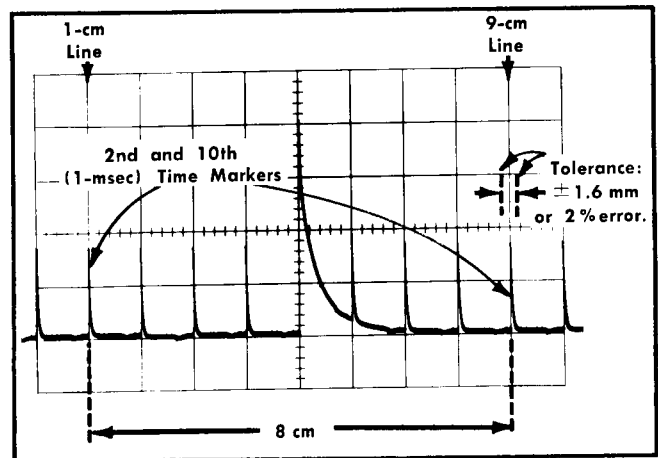

Fig. 5-8. Determining sweep-rate accuracy.

24. Adjust X1 CAL (X1 Sweep Calibration) R566—Horizontal Amplifier

- a. Set the SWEEP MAGNIFIER switch to X1 OFF.
- b. Adjust the X1 CAL R566 control (see Fig. 5-2) so the 1-msec markers are spaced 1-cm apart and so the 1-msec markers at the 1-cm and 9-cm points coincide with the graticule lines.
- c. Due to some interaction between the X10 CAL and X1 CAL adjustments, repeat steps 23 and 24 until the timing is correct.

25. Check MAG ON Neon—Horizontal Amplifier

- a. Check that the MAG ON neon lights when the SWEEP MAGNIFIER switch is set to each one of these positions: X2, X5, and X10.
- b. Set the SWEEP MAGNIFIER switch to X1 OFF.

26. Adjust B SWEEP LENGTH R125—B Sweep Generator

- a. Check that the display is positioned to start at the left side of the graticule or 0-cm line.
- b. Adjust the B SWEEP LENGTH R125 control (see Fig. 5-2) for a sweep length of 10.5 cm. When the adjustment is made correctly, there will be five 100-μsec time marks after the 5-msec time mark located at the 10-cm graticule line.

27. Check B VARIABLE (TIME/CM) and UNCALIBRATED NEON—'B' Sweep Timing Switch

- a. Set the time-mark generator for 10-msec and 5-msec timemark output.

Calibration — Type 546/RM546

- b. Adjust the B TRIGGERING LEVEL control to trigger on the 10-msec time markers.
- c. Rotate the B VARIABLE (TIME/CM) control a few degrees in the counterclockwise direction. The UN-CALIBRATED neon should light as the switch on the control is activated.
- d. Rotate the B VARIABLE control to its fully counterclockwise position. At least 25 msec of time for a distance of 10 cm should be displayed to indicate a ratio of 2.5 to 1. That is, the 5-msec markers should be spaced at intervals of 2 cm or less.
- e. Set the B VARIABLE control to the CALIBRATED position.

28. Adjust DELAY START R418—Delay Pickoff

- a. Apply 1-msec only time markers to the TU-7 Ext Input connector.
- b. Set the oscilloscope front-panel controls to the following positions:

A TRIGGERING MODE	AUTO
A TIME/CM	10 μ sec
HORIZONTAL DISPLAY	B INTENS BY 'A'

(The remaining front-panel controls at this point in the procedure are set to the positions listed in Table 5-6.)

TABLE 5-6

CRT Controls	
INTENSITY	≈ 3.5
FOCUS	≈ 5
ASTIGMATISM	≈ 5
SCALE ILLUM	≈ 8
Time Base A	
TRIGGERING LEVEL	0; knob pulled outward
TRIGGERING—	
SLOPE	+
COUPLING	AC
SOURCE	NORM INT
VARIABLE (TIME/CM)	CALIBRATED
Horizontal Display	
SWEEP MAGNIFIER	X1 OFF
Single Sweep Switch	NORMAL
Main Time Base (B)	
TRIGGERING LEVEL	0; knob pulled outward
TRIGGERING—	
SLOPE	+
COUPLING	AC
SOURCE	NORM INT
VARIABLE (TIME/CM)	CALIBRATED
TIME/CM	1 mSEC
BRIGHTNESS	Fully cw

Other Oscilloscope Controls	
DELAY-TIME MULTIPLIER	1.00
HORIZONTAL POSITION	Approximately centered
VERNIER (HORIZONTAL POSITION)	Centered
AMPLITUDE CALIBRATOR	OFF

Type TU-7	
Variable	≈ 3.5
Test Function	Low Load
Vertical Position	Approximately centered

- c. Set the TU-7 Variable control so the display is about 3 cm in amplitude.
- d. Set the B MODE switch to TRIG and adjust the B TRIGGERING LEVEL control for stable triggering on the 1-msec time markers.
- e. Adjust the BRIGHTNESS control in the counterclockwise direction and the INTENSITY control in the clockwise direction to make the brightened portion of the display easily distinguishable (see Fig. 5-9a).
- f. Rotate the DELAY-TIME MULTIPLIER control fully counterclockwise and check for a dial reading of 0.10. If the dial reading is not 0.10, loosen the set screw in the knob. Reposition the knob so the dial reading is 0.10 and then retighten the set screw.
- g. Rotate the DELAY-TIME MULTIPLIER control fully clockwise and check for a minimum dial reading of 10.10.
- h. Rotate the DELAY-TIME MULTIPLIER control to read 1.00.
- i. Adjust the DELAY START R418 control (see Fig. 5-2) so the 2nd 1-msec time marker on the B display is brightened (see Fig. 5-9a).
- j. Set the HORIZONTAL DISPLAY switch to A DLY'D and set the DELAY START R148 control so the rising portion is displayed (see Fig. 5-9b) at the very start of the sweep trace. The A display is a 100X magnification of the brightened portion of the B display.

29. Adjust DELAY STOP R415—Delay Pickoff

- a. Set the DELAY-TIME MULTIPLIER control to 9.00.
- b. Set the HORIZONTAL DISPLAY switch to B INTENS BY 'A'.
- c. Adjust the DELAY STOP R415 control (see Fig. 5-2) so the 10th 1-msec marker on the B display is brightened.
- d. Set the HORIZONTAL DISPLAY switch to A DLY'D and adjust the DELAY STOP, R415, so the rising portion of the marker is displayed (see Fig. 5-9b) at the very start of the trace. If the adjustment is made correctly, the display obtained in this step should appear the same as the display obtained when performing step 28j and as shown in Fig. 5-9b.
- e. Due to interaction between the DELAY START and DELAY STOP adjustments, set the DELAY-TIME MUL-

TIPLIER control to 1.00 and repeats steps 28i through 29d until the A sweep starts at the same point on the 1-cm and 9-cm time markers, respectively.

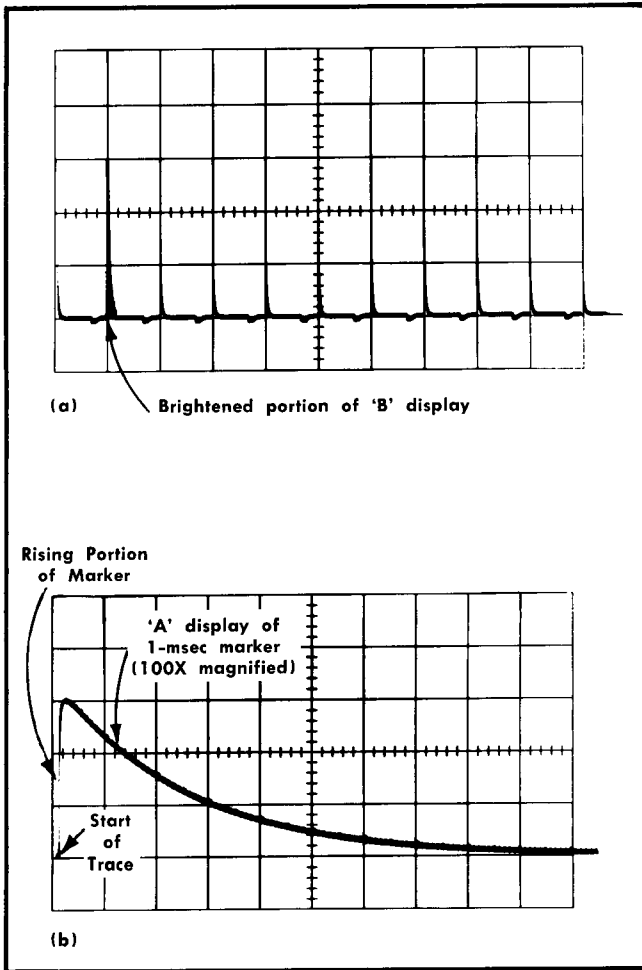

Fig. 5-9. Adjusting the DELAY START R418 control for proper A delayed-sweep starting time.

30. Check Incremental Accuracy—Delay Pickoff

- a. Set the DELAY-TIME MULTIPLIER control so the A sweep starts on the rising portion of the 1-msec markers for each setting as given in Table 5-7.

TABLE 5-7

Delay-Time Multiplier Control Setting	Tolerance
1.00	0 (Adjusted)
2.00	±2.0 minor div.
3.00	±2.0 minor div.
4.00	±2.0 minor div.
5.00	±2.0 minor div.
6.00	±2.0 minor div.
7.00	±2.0 minor div.
8.00	±2.0 minor div.
9.00	0 (Adjusted)

- b. Disconnect the coaxial cable from the TU-7 Ext Input connector.

31. Adjust C186 (Unblinking Compensator Capacitor)—B Sweep Generator

- a. Set the oscilloscope and TU-7 front-panel controls to these settings:

TU Test Function	Gain Set
'A' TRIGGERING LEVEL	Fully cw
'A' TIME/CM	50 μSEC
HORIZONTAL DISPLAY	A
'B' TRIGGERING LEVEL	Fully cw
'B' MODE	AUTO
'B' TIME/CM	50 μSEC
BRIGHTNESS	Fully cw
INTENSITY	Slightly below normal

- b. Use the TU-7 Vertical Position control to center the trace on the crt.
- c. Switch the HORIZONTAL DISPLAY back and forth between A and B and set the BRIGHTNESS control so the B trace is the same brightness as the A trace along the distance from about 2 cm to 10 cm.
- d. Adjust C186 (see Fig. 5-10) so the starting portion of the B trace is the same brightness as the starting portion of the A trace.

NOTE

Adjustment of C186 has the greatest effect on the first 8 mm distance of the B trace.

- e. Reconnect the coaxial cable from the time-mark generator to the TU-7 Ext Input Connector.

32. Adjust C90C (10-μSEC B Sweep-Rate Timing to DELAY-TIME MULTIPLIER)—B Sweep Timing Switch

- a. Set the time-mark generator for 10-μsec time-marker output.
- b. Set the TU-7 and oscilloscope front-panel controls as follows:

TU-7 Test Function	Low Load
A Time/CM	1 μSEC
HORIZONTAL DISPLAY	B INTENS BY 'A'
B MODE	TRIG
B TIME/CM	10 μSEC
BRIGHTNESS	Near midrange
INTENSITY	Normal intensity

- c. Adjust the B TRIGGERING LEVEL control to obtain a stable display.
- d. Set the TU-7 Variable control so the 'B' display is about 4 cm in amplitude and center the display vertically using the Vertical Position control.

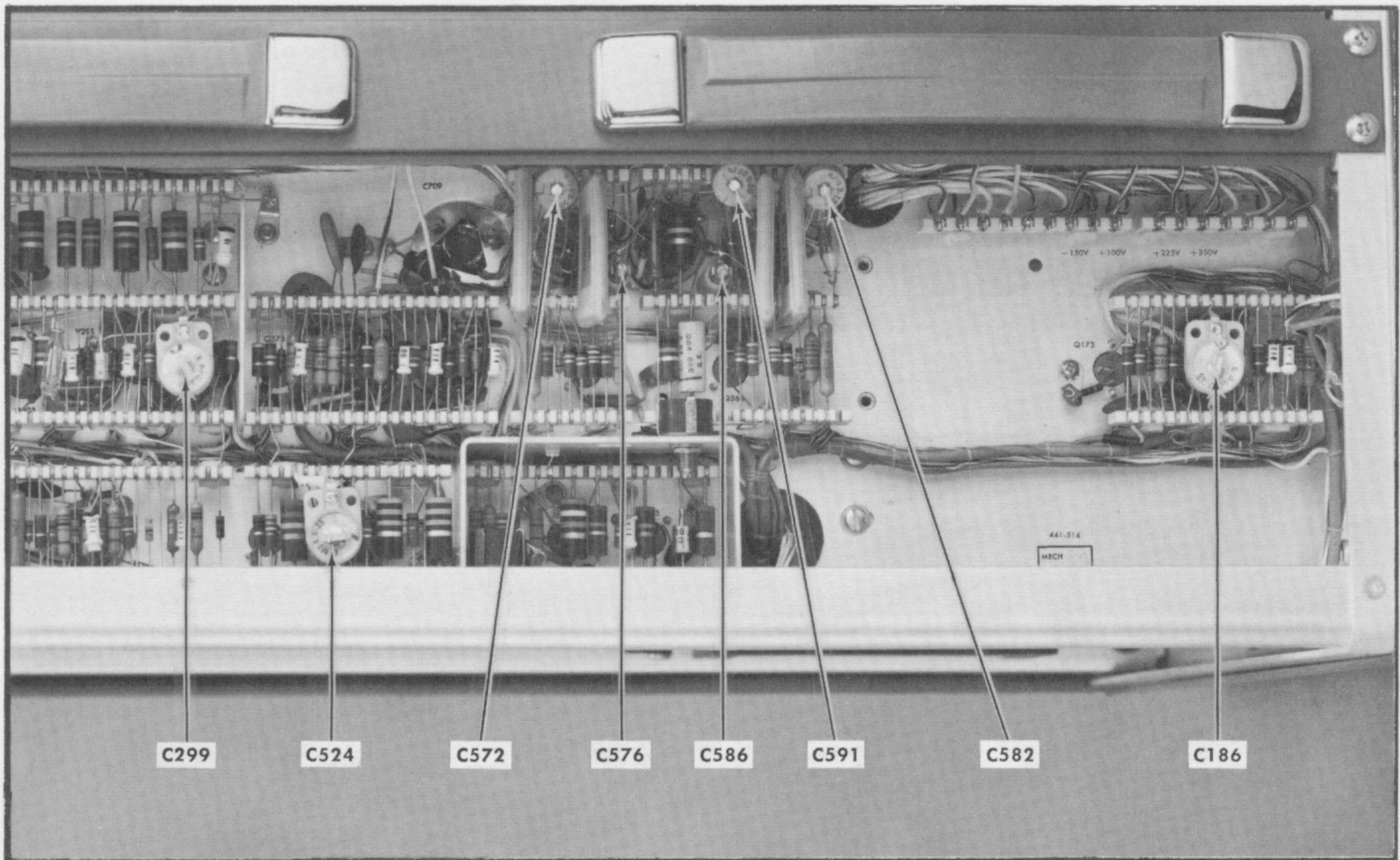

Fig. 5-10. Calibration adjustment locations (top right side view).

- e. Set the DELAY-TIME MULTIPLIER so the 50% point on the rising portion of the 2nd 10- μ sec time marker is brightened. Set the HORIZONTAL DISPLAY switch to A DLY'D and adjust the DELAY-TIME MULTIPLIER control to set the 50% point with greater accuracy.
- f. Note the DELAY-TIME MULTIPLIER dial reading in relation to 1.00.
- g. Set the HORIZONTAL DISPLAY switch to B INTENS BY 'A'.
- h. Set the DELAY-TIME MULTIPLIER control to read exactly 8.00 plus the dial reading obtained in the previous step.
- i. Adjust C90C (see Fig. 5-2) so the 50% point on the rising portion of the 10th time marker is the starting point of the brightened 10th time marker. Set the HORIZONTAL DISPLAY switch to A DLY'D to observe when the 50% point is reached accurately. After making the adjustment, set HORIZONTAL DISPLAY switch to B INTENS BY 'A'.
- j. Since there is interaction which affects the dial reading obtained in step 32g, repeat steps 32f through 32i until the DELAY-TIME MULTIPLIER dial indicates a difference of exactly 8.00 between the 2nd and 10th time markers.
- k. Check that the HORIZONTAL DISPLAY switch is set to B INTENS BY 'A'.

33. Adjust C90B (1- μ SEC B Sweep-Rate Timing to DELAY-TIME MULTIPLIER)—B Sweep Timing Switch

- a. Set the time-mark generator for 1- μ sec time-marker output.
- b. Set the A TIME/CM switch to .1 μ SEC and the B TIME/CM switch to 1 μ SEC.
- c. Adjust the TU-7 Variable control so the display is 4 cm in amplitude.
- d. Push the B TRIGGERING LEVEL knob in; adjust the B TRIGGERING LEVEL control to trigger on the time markers.
- e. Set the DELAY-TIME MULTIPLIER control so the 2nd time marker on the B display is brightened starting at the 50% point on the rising portion of the marker. Set the HORIZONTAL DISPLAY switch to A DLY'D to set the 50% point accurately (similar to the procedure used in step 32e).
- f. Note the DELAY-TIME MULTIPLIER dial reading.
- g. Set the HORIZONTAL DISPLAY switch to B INTENS BY 'A'.
- h. Set the DELAY-TIME MULTIPLIER control to read exactly 8.00 plus the dial reading noted in the previous step.

- i. Adjust C90B (see Fig. 5-2) so the 50% starting point on rising portion of the 10th time marker is brightened. Set the HORIZONTAL DISPLAY switch to A DLY'D to observe when the point is accurately reached, then set the HORIZONTAL DISPLAY switch to B INTENS BY 'A'.
- j. Due to interaction that affects the DELAY-TIME MULTIPLIER reading that was obtained for the 2nd time marker, repeat steps 33e through 33i until the DELAY-TIME MULTIPLIER dial indicates an exact 8.00 difference between the 2nd and 10th time markers.
- k. Check that the HORIZONTAL DISPLAY switch is set to B INTENS BY 'A'.

34. Adjust C90A (.5- μ SEC B Sweep-Rate Timing to the DELAY-TIME MULTIPLIER)—B Sweep Timing Switch

- a. Check that the time-mark generator is set for 1- μ sec marker output.
- b. Connect a coax cable from the trigger out connector on the time-mark generator to the B TRIGGER INPUT connector.
- c. Set the trigger rate of the time-mark generator for 10- μ sec trigger output.
- d. Set the B TIME/CM switch to .5 μ SEC and set the B source switch to EXT.
- e. Adjust C90A (see Fig. 5-2) for 1 marker per 2 cm. Disregard the first marker when making the adjustment for correct timing.

35. Adjust C99 (B Sweep Output Compensation) B Sweep Generator

- a. Set the time-mark generator for 10-mc sine-wave output.
- b. Set the HORIZONTAL DISPLAY switch to B.
- c. Set the B TIME/CM switch to .1 μ SEC.
- d. Use the TU-7 Vertical Position control to center the display vertically and adjust the variable control so the display is about 4 cm in amplitude.
- e. Using the oscilloscope HORIZONTAL POSITION control, position the tip of the 2nd sine wave to align with the 1-cm graticule line.
- f. Adjust C99 (see Fig. 5-2) for correct timing of 1 cycle per cm. (C99 is primarily a linearity adjustment.)
- g. Due to interaction between the adjustment of C99 and C90A, set the HORIZONTAL DISPLAY switch to B INTENS BY 'A' and repeat the procedure for the adjustments outlined in steps 34a through 35f until the desired results are obtained.
- h. Set the HORIZONTAL DISPLAY switch to A DLY'D and the DELAY-TIME MULTIPLIER control to 1.00.
- i. Using the HORIZONTAL POSITION control, position the display to the right so the start of the sweep can be observed.

- j. Adjust the B TRIGGERING LEVEL control so the sweep starts at the 50% point on the rising portion of the first sine wave.
- k. Using the TU-7 Vertical Position and the oscilloscope HORIZONTAL POSITION controls, position starting point of the first sine wave behind the intersection of a vertical and a horizontal graticule line. Use this intersection as a reference point.
- l. Set the DELAY-TIME MULTIPLIER control to 9.00.
- m. Readjust C90A to obtain the same starting point on the first displayed sine wave as was obtained in step 35k.

36. Check .2- μ SEC/CM Sweep Rate—B Sweep Timing Switch

- a. Set the DELAY-TIME MULTIPLIER control to 1.00 and the B TIME/CM switch to .2 μ SEC.
- b. Note the starting point of the sweep on the first sine wave.
- c. Set the DELAY-TIME MULTIPLIER control to obtain the same starting point with the control set near 9.00. Tolerance is $\pm 1\%$ or ± 8 minor divisions.

37. Recheck .5- μ SEC/CM Sweep Rate—B Sweep Timing Switch

- a. Set the time-mark generator for 5-mc sine-wave output.
- b. Set the B TIME/CM switch to .5 μ SEC.
- c. Set the DELAY-TIME MULTIPLIER control to 1.00.
- d. Adjust the B TRIGGERING LEVEL control to make the sweep start at a convenient reference point on the first sine wave.
- e. Set the DELAY-TIME MULTIPLIER control to about 9.00 so the sweep starts at the same point as in step 37d. Note the dial reading from 9.00. Tolerance is $\pm 1\%$ or ± 8 minor divisions.

38. Check 2- μ SEC through 5-SEC/CM Sweep Rates —B Sweep Timing Switch

- a. Set the B TIME/CM switch to 2 μ SEC and the B TRIGGERING SOURCE switch to NORM INT.
- b. Set the HORIZONTAL DISPLAY switch to B INTENS BY 'A'.
- c. Starting with the 2- μ SEC/CM B sweep rate, check the Main Time Base (B) sweep rates using Table 5-7 as a guide. Use the DELAY-TIME MULTIPLIER control and the A DLY'D position of the HORIZONTAL DISPLAY switch to determine the sweep-rate timing accuracy. The difference in dial readings between the "1.00" and "9.00" setting should be 8.00 within a tolerance of $\pm 1\%$ for each of the sweep rates.

TABLE 5-7

B TIME/CM Setting Switch	A TIME/CM Switch Setting	Time-Mark Generator Output	Markers Per Centimeter on B Display
2 μSEC	.1 μSEC	1 μsec	2
5 μSEC	.1 μSEC	5 μsec	1
10 μSEC*	1 μSEC	10 μsec	1
20 μSEC	1 μSEC	10 μsec	2
50 μSEC	1 μSEC	50 μsec	1
.1 mSEC	10 μSEC	100 μsec	1
.2 mSEC	10 μSEC	100 μsec	2
.5 mSEC	10 μSEC	500 μsec	1
1 mSEC*	.1 mSEC	1 msec	1
2 mSEC	.1 mSEC	1 msec	2
5 mSEC	.1 mSEC	5 msec	1
10 mSEC	1 mSEC	10 msec	1
20 mSEC	1 mSEC	10 msec	2
50 mSEC	1 mSEC	50 msec	1
.1 SEC	10 mSEC	100 msec	1
.2 SEC	10 mSEC	100 msec	2
.5 SEC	10 mSEC	500 msec	1
1 SEC	.1 SEC	1 sec	1
2 SEC	.1 SEC	1 sec	2
5 SEC	.1 SEC	5 sec	1

*Adjusted previously.

39. Adjust C572 and C582 (High-Speed Sweep Length Compensation)—Horizontal Amplifier

- a. Set the oscilloscope front panel controls to these settings:
 HORIZONTAL DISPLAY B
 B TRIGGERING SOURCE EXT
 B TIME/CM .1 μSEC
- b. Set the time-mark generator for 10-mc sine-wave output.
- c. Adjust the INTENSITY control so the display is easily visible while adjusting the B TRIGGERING LEVEL control to obtain a stable display.
- d. Using the TU-7 Vertical Position control, center the display. Adjust the Variable control so the display is about 4 cm in amplitude.
- e. Adjust the HORIZONTAL POSITION control to position the 2nd cycle to align with the 1-cm graticule line.
- f. Recheck the sweep-rate timing for 1 cycle per cm. If timing is not accurate, carefully readjust C99 for exact timing of 1 cycle per cm from the 1-cm graticule line to the 9-cm graticule line.
- g. Check that C576 and C586 (see Fig. 5-10) slug-adjusting screws are about six turns above the metal wiper contacts of the capacitors.
- h. Set the time-mark generator for 50-mc sine-wave output.

- i. Set the TU-7 Variable control so the display is about 4 cm in amplitude.
- j. Set the SWEEP MAGNIFIER switch to X10.
- k. Adjust the B TRIGGERING LEVEL control to obtain a stable display.
- l. Adjust C572 and C582 (see Fig. 5-10) for maximum center sweep expansion. (Use a low-capacitance alignment tool when making the adjustments.)

40. Adjust C591 (High-Speed Sweep Linearity)—Horizontal Amplifier

Adjust C591 (see Fig. 5-10) for best display linearity of 1 cycle per 2 cm.

41. Adjust C576 and C586 (High-Speed Timing Adjustments)—Horizontal Amplifier

Adjust C576 and C586 in equal increments for best timing of 1 cycle per 2 cm from the 2-cm graticule line to the 8-cm graticule line.

NOTE

If best timing cannot be obtained and the sweep seems too long, readjust C572 slightly to reduce the displayed gain. If C576 and C586 do not seem to have enough range, repeat steps 39 through 41. If repeat adjustment procedure causes timing to worsen, C576 and C586 slug-adjusting screws are probably turned in too far. Try presetting the C576 and C586 screws about 7 or 8 turns above the contacts and then repeat steps 39 through 41.

42. Adjust C557H (X10 SWEEP MAGNIFIER Compensation)—Horizontal Amplifier

- a. Rotate the HORIZONTAL POSITION and VERNIER controls clockwise so the start of the sweep (or display) can be seen. Then, position the tip of a cycle occurring 40 nsec or more from the start of the sweep to coincide with the 1-cm graticule line.
- b. Adjust C557H (see Fig. 5-2) for best timing of 1 cycle per 2 cm from the 1-cm to 8-cm graticule lines. If necessary, retouch C591 to obtain best linearity.
- c. Using the HORIZONTAL POSITION control, position the center of the sweep into view. If the timing needs to be improved, retouch C572 and/or repeat steps 39 through 42c.
- d. Set the SWEEP MAGNIFIER switch to OFF.
- e. Using the HORIZONTAL POSITION and VERNIER controls, position the display so the end of the sweep coincides with the 7-cm graticule line.
- f. Set the SWEEP MAGNIFIER switch to X10.
- g. Note the timing error of the display from the 1-cm to the 9-cm graticule lines; tolerance should be within ±5% or ±4 mm.

43. Check Timing Accuracy—Horizontal Amplifier

Check the timing accuracy of the display between the 4th cm and 80th cm of the sweep. Magnified-timing in this region must be within $\pm 5\%$ or less. If, in the 20th-cm region some non-linearity is observed, readjust C591 to make the sweep more linear.

NOTE

With some time and care spent in making the adjustments described in steps 39 through 43 as accurately as possible, the magnified sweep timing can be adjusted to $\pm 5\%$ or better.

44. Adjust C557F (X5 SWEEP MAGNIFIER Compensation)—Horizontal Amplifier

- a. Set the SWEEP MAGNIFIER switch to X5.
- b. Adjust C557F (see Fig. 5-2) for 1 cycle per cm after the first 2 cm from the start of the sweep.

45. Adjust C557D (X2 SWEEP MAGNIFIER Compensation)—Horizontal Amplifier

- a. Set the SWEEP MAGNIFIER switch to X2.
- b. Adjust C557D (see Fig. 5-2) for $2\frac{1}{2}$ cycles per cm after the first cm from the start of the sweep.

46. Adjust A SWEEP LENGTH R325—A Sweep Generator

- a. Set the time-mark generator for 100- μ sec, 1-msec and 5-msec time-marker output.
- b. Set the front-panel controls of the oscilloscope to these settings.

A TIME/CM	1 mSEC
HORIZONTAL DISPLAY	A
SWEEP MAGNIFIER	X1 OFF

Table 5-8 lists the settings of the remaining front panel controls up to this point in the procedure.

TABLE 5-8

CRT Controls	
INTENSITY	≈ 4
FOCUS	≈ 5
ASTIGMATISM	≈ 5
SCALE ILLUM	≈ 8
Time Base A	
TRIGGERING LEVEL	$+20^\circ$; knob pulled outward
TRIGGERING—	
MODE	AUTO
SLOPE	+
COUPLING	AC
SOURCE	NORM INT
VARIABLE (TIME/CM)	CALIBRATED

Horizontal Display

Single Sweep Switch NORMAL

Main Time Base (B)

TRIGGERING LEVEL ≈ 0 ; knob pushed in

TRIGGERING—

MODE TRIG

SLOPE +

COUPLING AC

SOURCE EXT

VARIABLE (TIME/CM) CALIBRATED

TIME/CM .1 mSEC

BRIGHTNESS Fully cw

Other Oscilloscope Controls

DELAY-TIME MULTIPLIER 9.00

HORIZONTAL POSITION $+45^\circ$ from center

VERNIER (HORIZONTAL POSITION) Centered

AMPLITUDE CALIBRATOR OFF

Type TU-7

Variable ≈ 5

Test Function Low Load

Vertical Position Approximately centered

- c. Set the TU-7 Variable control so the display is 4 cm in amplitude.
- d. Adjust the A TRIGGERING LEVEL control so the sweep triggers on the 5-msec time markers.
- e. Set the HORIZONTAL POSITION and VERNIER controls so the end of the sweep is located near the center of the crt.
- f. Set the SWEEP MAGNIFIER switch to X10.
- g. Set the A SWEEP LENGTH R235 control (see Fig. 5-2) so there are five 100- μ sec markers after the last 5-msec marker. Thus the A sweep length is 10.5 cm long.

47. Adjust A SWP CAL (A Sweep Calibration) R290Y—A Sweep Timing Switch

- a. Set the HORIZONTAL POSITION and VERNIER controls to position the start of the display at the 0-cm graticule line. Then, set the controls so the 2nd 100- μ sec marker aligns with the 1-cm graticule line.
- b. Adjust the A SWP CAL R290Y control (see Fig. 5-2) so the 100- μ sec markers are spaced 1 cm apart and so the 2nd and 10th 100- μ sec markers coincide with their 1-cm and 9-cm graticule lines, respectively.

48. Check A VARIABLE (TIME/CM) and UNCALIBRATED Neon—A Sweep Timing Switch

- a. Set the time-mark generator for 10-msec and 5-msec time-marker output.
- b. Set the SWEEP MAGNIFIER switch to X1 OFF.

Calibration — Type 546/RM546

- c. Set the HORIZONTAL POSITION control to position the display to start at the 0-cm graticule line.
- d. Adjust the TU-7 Variable control so the 10-msec markers are about 4-cm in amplitude.
- e. Adjust the A TRIGGERING LEVEL control to trigger the sweep on the 10-msec markers.
- f. Rotate the A VARIABLE (TIME/CM) control a few degrees in the counterclockwise direction. Check that the UNCALIBRATED neon lights as the switch on the control is activated.
- g. Rotate the A VARIABLE control to its fully counterclockwise position. At least 25 msec of time for a distance of 10 cm should be displayed to indicate a ratio of at least 2.5 to 1. That is, each 5-msec marker should be spaced at intervals of 2 cm or less.
- h. Set the A VARIABLE control to the CALIBRATED position.

49. Adjust C290C (10- μ SEC A Sweep-Rate Timing) —A Sweep Timing Switch

- a. Set the time-mark generator for 10- μ sec time marker output.
- b. Set the A TIME/CM switch to 10 μ SEC.
- c. Set the TU-7 Variable control so the markers are about 4 cm in amplitude.
- d. Adjust the A TRIGGERING LEVEL control to trigger on the 10- μ sec time markers.
- e. Adjust C290C (see Fig. 5-2) so the time markers are spaced 1 cm apart and for correct timing of the markers at the 1-cm and 9-cm graticule lines.

50. Adjust C290B (1- μ SEC A Sweep-Rate Timing) —A Sweep Timing Switch

- a. Set the time-mark generator for 1- μ sec time-marker output.
- b. Set the A TIME/CM switch to 1 μ SEC.
- c. Set the TU-7 Variable control so the markers are about 4 cm in amplitude.
- d. Adjust C290B (see Fig. 5-2) so the time markers are spaced 1-cm apart and for correct timing of the markers at the 1-cm and 9-cm graticule lines.

NOTE

If exact 1-cm spacing of the time markers cannot be obtained by adjusting C290B, proceed to the next step since C299 affects the linearity of the first one-half of the A sweep.

51. Adjust C299 (A Sweep Output Compensation) —A Sweep Generator

- a. If the markers do not coincide accurately when adjusting C290B due to some non-linearity in the A sweep, adjust C299 (see Fig. 5-10) for best linearity for the first half of the A sweep.
- b. Readjust C290B for correct timing of the markers for the last half of the sweep. Repeat the adjustment of C290B and C299 for best sweep-rate timing of 1 marker per cm from the 2nd marker to the 10th marker.

52. Adjust C290A (1.5- μ SEC A Sweep Rate Timing) —A Sweep Timing Switch

- a. Set the A TIME/CM switch to .5 μ SEC.
- b. Using the HORIZONTAL POSITION control, position the display so the tip of the 2nd marker coincides with the 1-cm graticule line.
- c. Adjust C290A (see Fig. 5-2) so there is one marker every 2 cm. The 2nd and 6th markers should coincide accurately with the 1-cm and 9-cm graticule lines, respectively.

53. Readjust C299 (1.1- μ SEC A Sweep Rate Timing) —A Sweep Generator

- a. Set the time-mark generator for 10-mc sine-wave output.
- b. Set the A TIME/CM switch to .1 μ SEC.
- c. Adjust the A TRIGGERING LEVEL controls to obtain a stable display.
- d. Position the 2nd sine-wave to align with the 1-cm graticule line.
- e. Readjust C299 for proper timing of 1 cycle per cm from the 1-cm to 9-cm graticule lines.
- f. Repeat steps 52 and 53. C299 and C290A adjustments interact.

54. Check .1- μ SEC/CM through 5-SEC/CM Sweep Rates—A Sweep Timing Switch

- a. Check that the A TIME/CM switch is set to .1 μ SEC.
- b. Set the A TRIGGERING MODE switch to TRIG.
- c. Starting with the .1 μ SEC/CM sweep rate, check each of the Time Base A sweep rates using Table 5-9 as a guide. Tolerance for the fixed (non-adjustable) sweep rates is $\pm 2\%$ or ± 1.6 mm.

TABLE 5-9

'A' TIME/CM Switch Setting	Time-Mark Generator Output	Check For
.1 μSEC*	10 mc	1 cycle/cm
.2 μSEC	5 mc	1 cycle/cm
.5 μSEC*	1 μsec	1 marker/2 cm
1 μSEC	1 μsec	1 marker/cm
2 μSEC	1 μsec	2 markers/cm
5 μSEC	5 μsec	1 marker/cm
10 μSEC*	10 μsec	1 marker/cm
20 μSEC	10 μsec	2 markers/cm
50 μSEC	50 μsec	1 marker/cm
.1 mSEC	100 μsec	1 marker/cm
.2 mSEC	100 μsec	2 markers/cm
.5 mSEC	500 μsec	1 marker/cm
1 mSEC*	1 msec	1 marker/cm
2 mSEC	1 msec	2 markers/cm
5 mSEC	5 msec	1 marker/cm
10 mSEC	10 msec	1 marker/cm
20 mSEC	10 msec	2 markers/cm
50 mSEC	50 msec	1 marker/cm
.1 SEC	100 msec	1 marker/cm
.2 SEC	100 msec	2 markers/cm
.5 SEC	500 msec	1 marker/cm
1 SEC	1 sec	1 marker/cm
2 SEC	1 sec	2 markers/cm
5 SEC	5 sec	1 marker/cm

*Adjusted previously for exact timing.

- c. After checking the sweep rates, disconnect the Time-Mark Generator and interconnecting cables from the oscilloscope/TU-7 combination.

55. Adjust EXT HORIZ DC BAL R519—(External) Horizontal Amplifier

- a. Set the front-panel controls of the oscilloscope and TU-7 to the following settings.

Oscilloscope

A TRIGGERING LEVEL	Fully clockwise, pushed in
A MODE	AUTO
A SOURCE	EXT
A TIME/CM	1 mSEC
HORIZONTAL DISPLAY	EXT X1
VAR 10-1	Fully cw
B TRIGGERING LEVEL	Fully ccw

Type TU-7

Vertical Position	Centered
Variable	≈3

The remaining front-panel controls of the oscilloscope and TU-7 are already set to the positions listed in Table 5-10.

TABLE 5-10

CRT Controls	
INTENSITY	≈3.5
FOCUS	≈5
ASTIGMATISM	≈5
SCALE ILLUM	≈8
Time Base A	
TRIGGERING—	
SLOPE	+
COUPLING	AC
VARIABLE (TIME/CM)	CALIBRATED
Horizontal Display	
SWEEP MAGNIFIER	X1 OFF
Single Sweep Switch	NORMAL
Main Time Base (B)	
TRIGGERING—	
MODE	TRIG
SLOPE	+
COUPLING	AC
SOURCE	EXT
VARIABLE (TIME/CM)	CALIBRATED
TIME/CM	.1 mSEC
BRIGHTNESS	Fully cw
Other Oscilloscope Controls	
DELAY-TIME MULTIPLIER	9.00
HORIZONTAL POSITION	Centered
VERNIER (HORIZONTAL POSITION)	Centered
AMPLITUDE CALIBRATOR	OFF
Type TU-7	
Test Function	Low Load
b. Connect a single binding post adapter (item 9) to the TU-7 Ext Input connector.	
c. Connect an interconnecting lead (item 12) from the adapter at the TU-7 Ext Input connector to the SWEEP A connector on the oscilloscope.	
d. Connect an interconnecting lead (item 12) from the HORIZ INPUT connector to ground.	
e. Using the HORIZONTAL POSITION control, position the vertical free-running sweep trace to the center of the graticule. Check that the INTENSITY control is set to make the trace visible.	
f. Adjust the EXT HORIZ DC BAL R519 control (see Fig. 5-2) for no horizontal shift of the vertical trace while rotating the VAR 10-1 control.	
g. Disconnect the interconnecting lead from the HORIZ INPUT connector to ground.	

56. Adjust C524 Output Compensation—(External) Horizontal Amplifier

- a. Connect a BNC T connector to the oscilloscope CAL OUT connector.
- b. Connect a coaxial cable from one end of the BNC T connector to the A TRIGGER INPUT connector.
- c. Connect another coaxial cable from the other end of the BNC T connector through a coaxial connector adapter (item 10) to the HORIZ INPUT connector.
- d. Set the AMPLITUDE CALIBRATOR switch to .5 and adjust the A TRIGGERING LEVEL control to obtain a stable display.
- e. Check that the VAR 10-1 control is set fully clockwise.
- f. Set the HORIZONTAL POSITION control so the display is centered on the crt.
- g. Set the TU-7 Variable control so several cycles of the calibrator waveform is displayed (see Figs. 5-11a and 5-11b).

- h. Adjust C524 (see Fig. 5-10) for least distorted calibrator waveform (see Fig. 5-11a); that is, for minimum fast spike or rolloff.

57. Check Gain—(External) Horizontal Amplifier

- a. Set the AMPLITUDE CALIBRATOR switch to .1 VOLTS and check that the VAR 10-1 control is set fully clockwise.
- b. Adjust the A TRIGGERING LEVEL control to obtain a stable display.
- c. The calibrator waveform displayed on the crt should be greater than 1 cm in amplitude.

58. Check VAR 10-1 Control Range—(External) Horizontal Amplifier

- a. Set the AMPLITUDE CALIBRATOR switch to .5 VOLTS.
- b. Note the waveform amplitude in cm.
- c. Rotate the VAR 10-1 control fully counterclockwise.
- d. Check that the waveform amplitude is 1/10 the amplitude, or less, than the amplitude noted in step 58b.
- e. Rotate the VAR 10-1 control fully clockwise.

59. Adjust C503C (X10 Attenuator Compensation)—(External) Horizontal Amplifier

- a. Set the HORIZONTAL DISPLAY switch to EXT X10.
- b. Set the AMPLITUDE CALIBRATOR switch to 5 VOLTS.
- c. Adjust C503C (see Fig. 5-2) for optimum square-wave response. The display should exhibit no more than 5% hook on the positive-going or negative-going leading corner of the calibrator waveform. When C503C is properly adjusted, the calibrator waveform should appear similar to the display shown in Fig. 5-11a. Fig. 5-12 shows one form of distortion obtained if C503C is misadjusted.

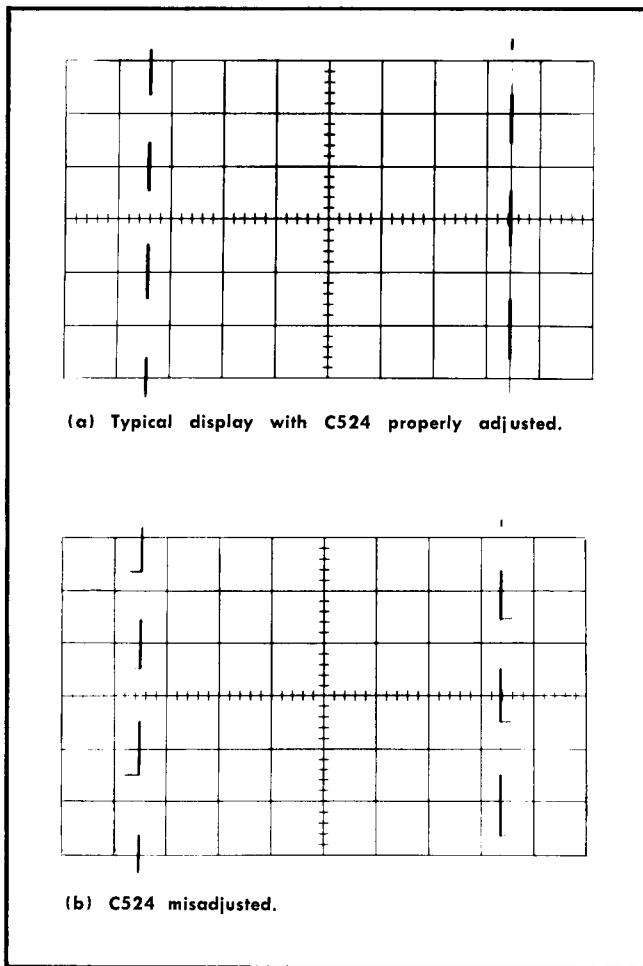

Fig. 5-11. Typical waveform displays with C524 properly adjusted and misadjusted.

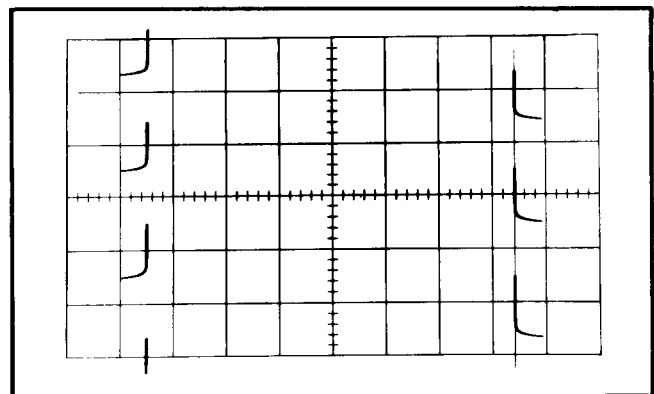

Fig. 5-12. Distortion obtained when C503C is misadjusted.

60. Check X10 Attenuation—(External) Horizontal Amplifier

- a. Set the HORIZONTAL DISPLAY switch to EXT X1 and check that the VAR 10-1 control is set fully clockwise.
- b. Set the AMPLITUDE CALIBRATOR switch to .5 VOLTS.
- c. Note the waveform amplitude in cm.
- d. Set the HORIZONTAL DISPLAY switch to EXT X10.
- e. Set the AMPLITUDE CALIBRATOR switch to 5 VOLTS and check the amplitude of the display. The signal amplitude should be within $\pm 3\%$ of that amplitude noted in step 59c.
- f. Set the HORIZONTAL DISPLAY switch to B.
- g. Disconnect the adapters, interconnecting lead and coaxial cables.

61. Check and/or Adjust High-Frequency Compensations—Vertical Amplifier

- a. Set the front-panel controls of the oscilloscope to the following positions:

A TRIGGERING MODE	TRIG
B TRIGGERING LEVEL	-20° from 0
B SOURCE	NORM
B TIME/CM	.1 μ SEC
SWEEP MAGNIFIER	X1 OFF
AMPLITUDE CALIBRATOR	OFF
- b. Set the TU-7 front-panel controls as follows:

Vertical Position	Centered
Test Function	+Pulse
Amplitude	≈ 7.5

The remaining pertinent front-panel controls up to this point in the procedure are already set to the positions listed in Table 5-11.

TABLE 5-11

CRT Controls	
INTENSITY	≈ 3.5
FOCUS	≈ 5
ASTIGMATISM	≈ 5
SCALE ILLUM	≈ 8
Time Base A	
TRIGGERING LEVEL	$+20^\circ$; knob pushed in
Horizontal Display	
HORIZONTAL DISPLAY	B
Single Sweep Switch	NORMAL
Main Time Base (B)	
TRIGGERING LEVEL	Knob pushed in
TRIGGERING—	
MODE	TRIG
SLOPE	+
COUPLING	AC
VARIABLE (TIME/CM)	CALIBRATED
BRIGHTNESS	Fully cw

Other Oscilloscope Controls
 HORIZONTAL POSITION -45° from center
 VERNIER (HORIZONTAL POSITION) Centered

Type TU-7
 Repetition Rate Med

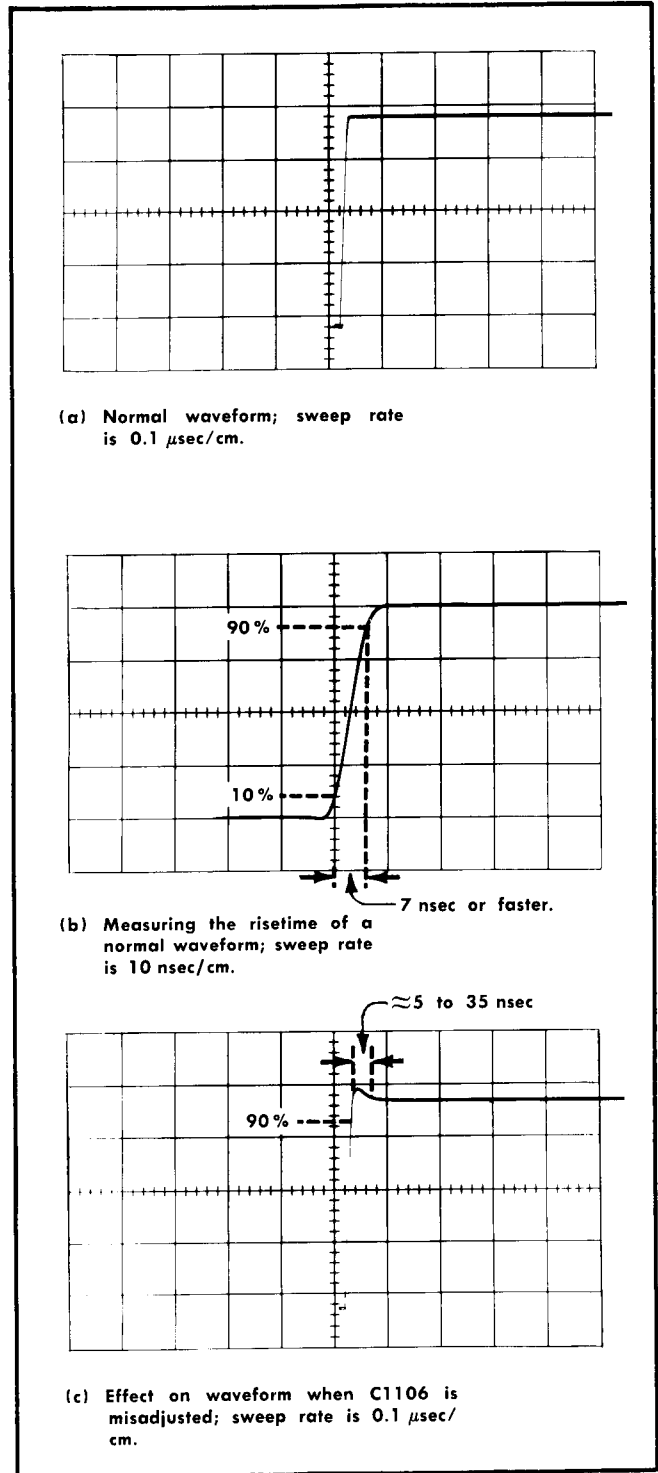

Fig. 5-13. Vertical Amplifier compensation checks and adjustments for optimum transient response.

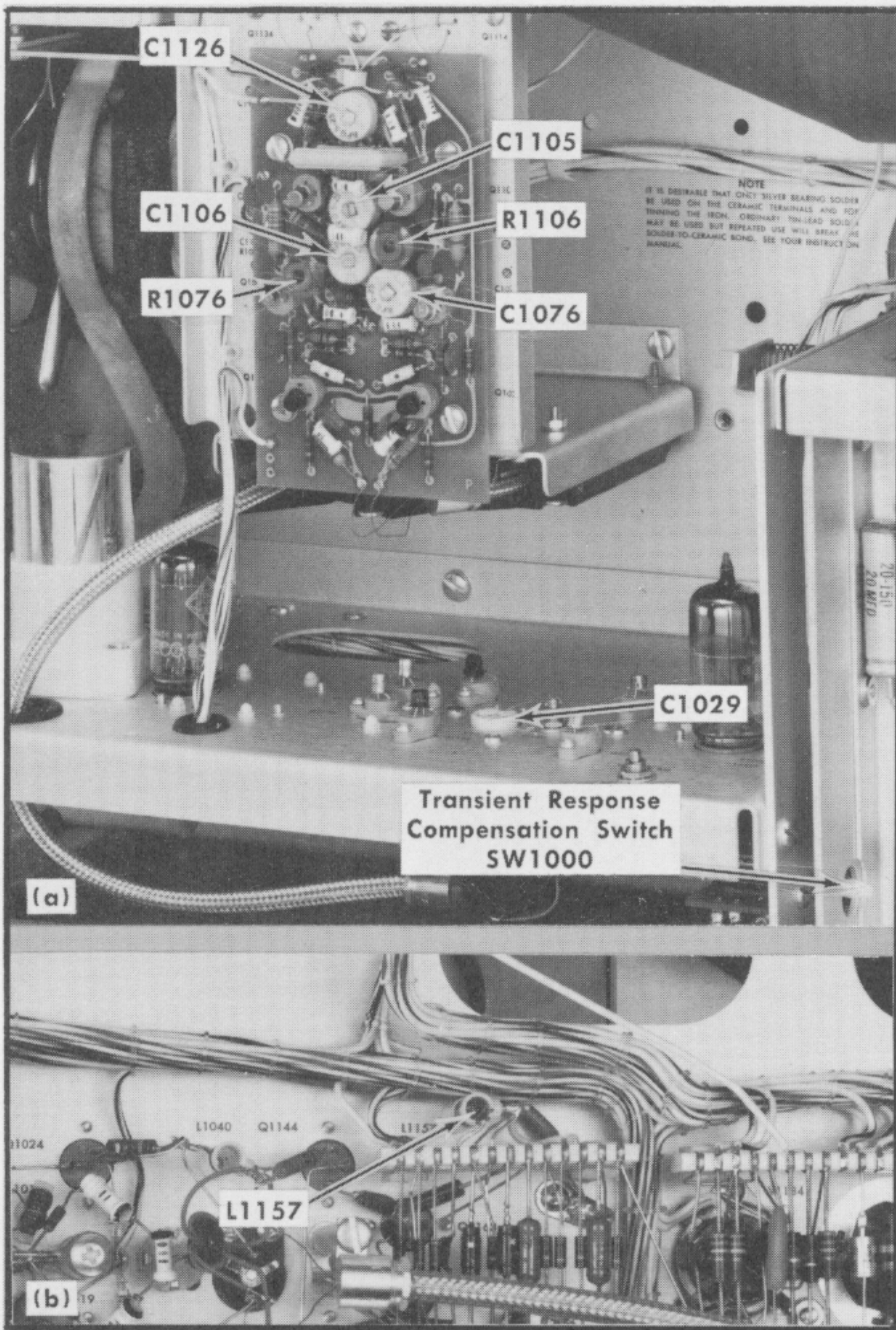

Fig. 5-14. (a) Vertical Amplifier high-frequency adjustments and Transient Response Compensation switch (center left side view) locations. (b) L1157 location (bottom left side view).

- c. Using the oscilloscope HORIZONTAL POSITION control, position the display to start near the graticule center.
- d. Set the TU-7 Amplitude and Vertical Position controls so the display is vertically centered on the crt and the amplitude of the step-waveform is exactly 4 cm.
- e. Using the TU-7 Vertical Position control, position the waveform downward about 2 mm for easier visibility away from the graticule lines.
- f. Adjust the INTENSITY control to increase the brightness of the display to normal viewing level.
- g. Adjust the FOCUS and ASTIGMATISM controls to produce a well-defined leading top corner on the step waveform.
- h. Examine the waveform for clean transient response. Typical waveform should appear similar to Fig. 5-13a.
- i. Set the SWEEP MAGNIFIER switch to X10.
- j. Measure the risetime of the rising portion of the waveform from the 10% point to the 90% point (see Fig. 5-13b). The risetime should not be any slower than 7-nsec based on a 3-nsec risetime pulse from

the TU-7. (Take into consideration sweep-rate timing error, if any, and/or geometry in the area where the measurement is made.)

- k. If the aberrations appear excessive and/or the risetime is slower than 7 nsec, set the SWEEP MAGNIFIER switch to X1 and adjust the high-frequency adjustments using Table 5-12 as a guide. Since the adjustments interact, it is necessary to readjust (go back over) the adjustments several times to obtain a waveform with good transient response. When making the adjustments, keep the step waveform vertically centered on the crt.

NOTE

To check the overall level and maintain a flat top when making the adjustments, use the different SWEEP MAGNIFIER switch positions.

TABLE 5-12

Vertical Amplifier High-Frequency Adjustments

Adjustment	For Location See Fig.	Approximate Area Affected*
L1157	5-14b	0 to 100 nsec, adjust for minimum wrinkles
C1029	5-14a	Termination bump** at 340 nsec
C1076	5-14a	0 to 15 nsec
C1105	5-14a	1 nsec to 4 nsec
C1106	5-14a	5 nsec to 35 nsec
C1126	5-14a	20 nsec to 80 nsec
R1076	5-14a	0 to 10 nsec
R1106	5-14a	2 nsec to 20 nsec

*Distance measured to the right starting from the 90% point on the rising portion of the waveform. For an example see Fig. 5-13c.

**If no bump appears, adjust C1029 for best risetime.

62. Check Transient Response Compensation Switch SW1000 — Vertical Amplifier

- a. Check that the B TIME/CM switch is set to .1 μ SEC and the SWEEP MAGNIFIER switch is set to X10.
- b. Depress the Transient Response Compensation SW1000 (see Fig. 5-14a). Check the risetime of the step waveform (see Fig. 5-15). Overall risetime should not be any slower than 10 nsec.

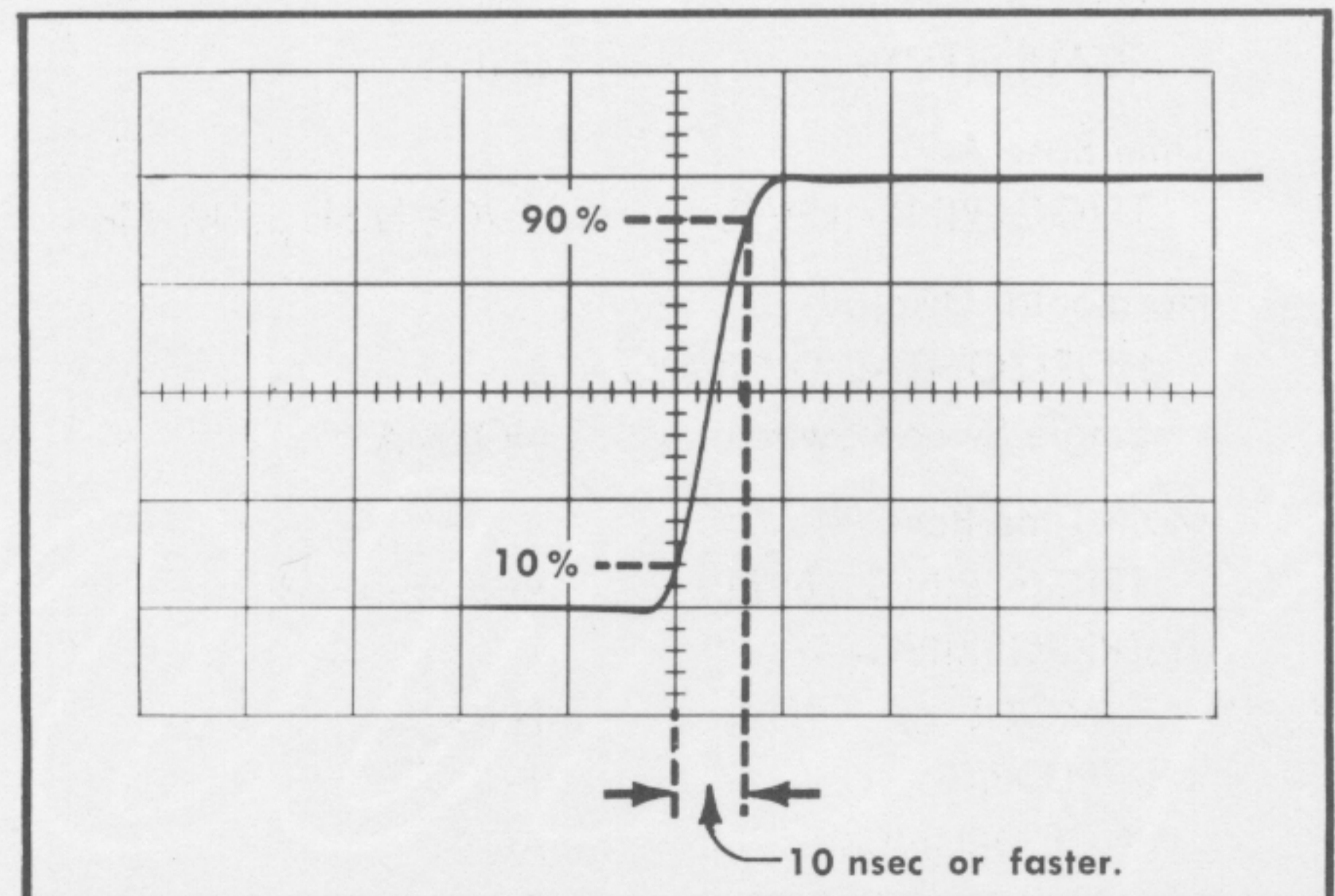

Fig. 5-15. Measuring the risetime of a normal waveform when SW1000 is actuated; sweep rate is 10 nsec/cm.

SECTION 6

PARTS LIST and DIAGRAMS

PARTS ORDERING INFORMATION

Replacement parts are available from or through your local Tektronix Field Office.



Changes to Tektronix instruments are sometimes made to accommodate improved components as they become available, and to give you the benefit of the latest circuit improvements developed in our engineering department. It is therefore important, when ordering parts, to include the following information in your order: Part number including any suffix, instrument type, serial number, and modification number if applicable.

If a part you have ordered has been replaced with a new or improved part, your local Tektronix Field Office will contact you concerning any change in part number.

ABBREVIATIONS AND SYMBOLS

a or amp	amperes	mm	millimeter
BHS	binding head steel	meg or M	megohms or mega (10^6)
C	carbon	met.	metal
cer	ceramic	μ	micro, or 10^{-6}
cm	centimeter	n	nano, or 10^{-9}
comp	composition	Ω	ohm
cps	cycles per second	OD	outside diameter
crt	cathode-ray tube	OHS	oval head steel
CSK	counter sunk	p	pico, or 10^{-12}
dia	diameter	PHS	pan head steel
div	division	piv	peak inverse voltage
EMC	electrolytic, metal cased	plstc	plastic
EMT	electrolytic, metal tubular	PMC	paper, metal cased
ext	external	poly	polystyrene
f	farad	Prec	precision
F & I	focus and intensity	PT	paper tubular
FHS	flat head steel	PTM	paper or plastic, tubular, molded
Fil HS	fillister head steel	RHS	round head steel
g or G	giga, or 10^9	rms	root mean square
Ge	germanium	sec	second
GMV	guaranteed minimum value	Si	silicon
h	henry	S/N	serial number
hex	hexagonal	t or T	tera, or 10^{12}
HHS	hex head steel	TD	toroid
HSS	hex socket steel	THS	truss head steel
HV	high voltage	tub.	tubular
ID	inside diameter	v or V	volt
incd	incandescent	Var	variable
int	internal	w	watt
k or K	kilohms or kilo (10^3)	w/	with
kc	kilocycle	w/o	without
m	milli, or 10^{-3}	WW	wire-wound
mc	megacycle		

SPECIAL NOTES AND SYMBOLS

X000	Part first added at this serial number.
000X	Part removed after this serial number.
*000-000	Asterisk preceding Tektronix Part Number indicates manufactured by or for Tektronix, or reworked or checked components.
Use 000-000	Part number indicated is direct replacement.
	Internal screwdriver adjustment.
	Front-panel adjustment or connector.

EXPLODED VIEW

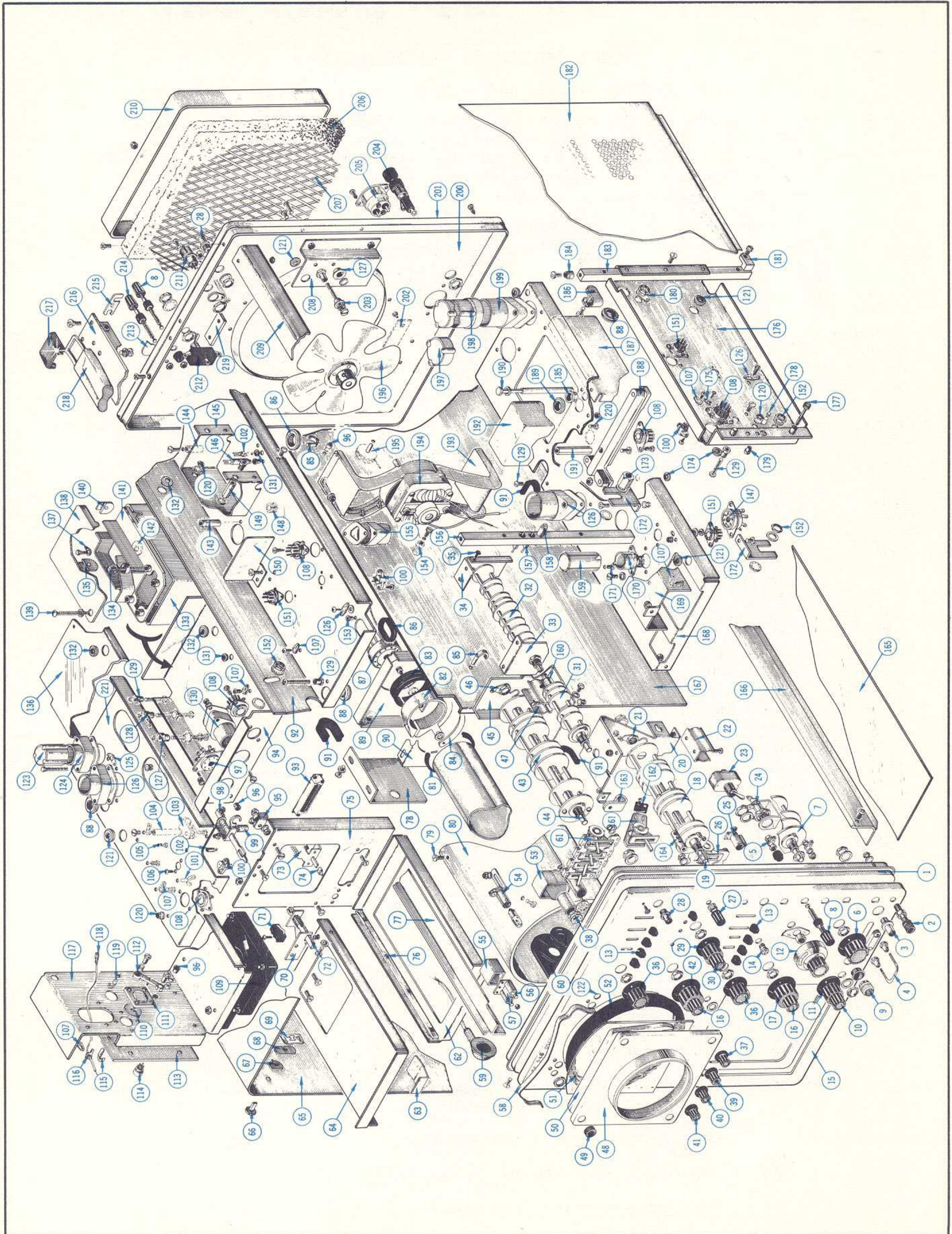

EXPLODED

REF. NO.	PART NO.	SERIAL NO.		QTY.	DESCRIPTION
		EFF.	DISC.		
1	387-757			1	PLATE, front sub-panel
	- - - -			-	Includes:
	354-056			1	RING, ornamental
2	129-020			2	POST, binding, assembly
	- - - -			-	Each Consisting Of:
	355-503			1	STEM, adapter
	200-072			1	CAP
	- - - -			-	Mounting Hardware For Each: (not included)
	210-445			1	NUT, hex, 10-32 x $\frac{3}{8}$ inch
	210-206			1	LUG, solder, SE10, long
3	131-274			1	CONNECTOR, chassis mount, BNC
4	214-335			1	BOLT, current loop
	- - - -			-	Mounting Hardware: (not included)
	210-593			2	NUT, current loop, hex, 5-40 x $\frac{1}{4}$ inch
	361-059			1	SPACER, current loop
	210-849			2	WASHER, fiber, #4
	210-801			2	WASHER, 5S x $\frac{9}{32}$ inch
	210-201			2	LUG, solder, SE4
	210-442			2	NUT, hex, 3-48 x $\frac{3}{16}$ inch
5	210-202			2	LUG, solder, SE6
	- - - -			-	Mounting Hardware For Each: (not included)
	210-407			1	NUT, hex, 6-32 x $\frac{1}{4}$ inch
6	366-115			1	KNOB, AMPLITUDE CALIBRATOR, large charcoal
	- - - -			-	Includes:
	213-004			1	SCREW, set, 6-32 x $\frac{3}{16}$ inch HSS
7	262-599			1	SWITCH, AMPLITUDE CALIBRATOR, wired
	- - - -			-	Includes:
	260-536			1	SWITCH, unwired
	- - - -			-	Mounting Hardware: (not included)
	210-413			1	NUT, hex, $\frac{3}{8}$ -32 x $\frac{1}{2}$ inch
	210-012			2	LOCKWASHER, internal, $\frac{3}{8}$ x $\frac{1}{2}$ inch
8	129-064			7	POST, binding
	- - - -			-	Mounting Hardware For Each: (not included)
	358-181			1	BUSHING, nylon, charcoal
	210-457			1	NUT, keps, 6-32 x $\frac{3}{16}$ inch
9	378-518			1	JEWEL, pilot light
10	366-032			1	KNOB, VERNIER, small red
	- - - -			-	Includes:
	213-004			1	SCREW, set, 6-32 x $\frac{3}{16}$ inch HSS
11	366-159			1	KNOB, HORIZONTAL POSITION, large charcoal
	- - - -			-	Includes:
	213-004			1	SCREW, set, 6-32 x $\frac{3}{16}$ inch HSS
	- - - -			-	Mounting Hardware For Pot:
	210-413			1	NUT, hex, $\frac{3}{8}$ -32 x $\frac{1}{2}$ inch
	210-012			1	LOCKWASHER, internal, $\frac{3}{8}$ x $\frac{1}{2}$ inch
	210-207			1	LUG, solder, $\frac{3}{8}$ inch
12	331-091			1	DIAL, DELAY-TIME MULTIPLIER
13	366-215			9	KNOB, lever
14	366-261			1	KNOB, BRIGHTNESS, gray delrin
	- - - -			-	Includes:
	214-395			1	SPRING, wire
15	333-761			1	PANEL, front
	- - - -			-	Mounting Hardware: (not included)
	213-088			3	SCREW, thread forming, 4-40 x $\frac{1}{4}$ inch PHS phillips
16	366-038			2	KNOB, VARIABLE, small red
	- - - -			-	Each Includes:
	213-004			1	SCREW, set, 6-32 x $\frac{3}{16}$ inch HSS
17	366-144			1	KNOB, "B" TIME/CM OR DELAY TIME, large charcoal
	- - - -			-	Includes:
	213-004			1	SCREW, set, 6-32 x $\frac{3}{16}$ inch HSS

EXPLODED VIEW (Cont'd.)

REF. NO.	PART NO.	SERIAL NO.		QTY.	DESCRIPTION
		EFF.	DISC.		
18	262-596			1	SWITCH, "B" TIME/CM OR DELAY TIME, wired
	- - - -			-	Includes:
	260-531			1	SWITCH, unwired
19	384-287			1	ROD, extension
	376-016			1	COUPLING, pot
20	406-898			1	BRACKET, "B" TIME/CM OR DELAY TIME switch
	- - - -			-	Mounting Hardware:
	210-449			2	NUT, hex, 5-40 x 1/4 inch
	210-006			2	LOCKWASHER, internal, #6
	348-003			1	GROMMET, 5/16 inch (not shown)
	- - - -			-	Mounting Hardware For Capacitor: (not shown)
	210-407			3	NUT, hex, 6-32 x 1/4 inch
	210-006			3	LOCKWASHER, internal, #6
	210-803			2	WASHER, 6L x 3/8 inch
21	- - - -			-	Mounting Hardware For Pot:
	210-413			2	NUT, hex, 3/8-32 x 1/2 inch
	210-012			1	LOCKWASHER, internal, 3/8 x 1/2 inch
	210-255			1	LUG, solder
22	352-061			1	HOLDER, component
	- - - -			-	Mounting Hardware:
	211-008			2	SCREW, 4-40 x 1/4 inch BHS
	210-004			2	LOCKWASHER, internal, #4
	210-406			2	NUT, hex, 4-40 x 3/16 inch
	- - - -			-	Mounting Hardware: (not included)
	210-413			1	NUT, hex, 3/8-32 x 1/2 inch
	210-013			1	LOCKWASHER, internal, 3/8 x 1 1/16 inch
	212-004			2	SCREW, 8-32 x 5/16 inch BHS
	212-023			1	SCREW, 8-32 x 3/8 inch BHS
	210-804			3	WASHER, 8S x 3/8 inch
	211-507			2	SCREW, 6-32 x 5/16 inch BHS
	210-803			2	WASHER, 6L x 3/8 inch
23	260-199			1	SWITCH, POWER ON, toggle
	- - - -			-	Mounting Hardware: (not included)
	210-473			1	NUT, switch 15/32-32 x 5/64 inch, 12 sided
	210-902			1	WASHER, .470 ID x 2 1/32 inch OD
	354-055			1	RING, locking, switch
	210-414			1	NUT, hex, 15/32-32 x 9/16 inch
24	136-026			1	SOCKET, light
25	352-067			3	HOLDER, neon, single
	- - - -			-	Mounting Hardware For Each: (not included)
	211-031			1	SCREW, 4-40 x 1 inch FHS
	210-406			2	NUT, hex, 4-40 x 3/16 inch
26	262-598			1	SWITCH, TRIGGERING "B", wired
	- - - -			-	Includes:
	260-493			1	SWITCH, MODE, lever
	- - - -			-	Mounting Hardware: (not included)
	213-088			2	SCREW, thread forming, 4-40 x 1/4 inch PHS phillips
	260-494			1	SWITCH, COUPLING, lever
	- - - -			-	Mounting Hardware: (not included)
	213-088			2	SCREW, thread forming, 4-40 x 1/4 inch PHS phillips
	260-495			1	SWITCH, SOURCE, lever
	- - - -			-	Mounting Hardware: (not included)
	213-088			2	SCREW, thread forming 4-40 x 1/4 inch PHS phillips
	260-452			1	SWITCH, SLOPE, lever
	- - - -			-	Mounting Hardware: (not included)
	213-088			2	SCREW, thread forming 4-40 x 1/4 inch PHS phillips
	406-943			1	BRACKET, lever switch
	- - - -			-	Mounting Hardware: (not included)
	210-586			4	NUT, keps, 4-40 x 1/4 inch
	210-201			1	LUG, solder, SE4

EXPLODED VIEW (Cont'd.)

REF. NO.	PART NO.	SERIAL NO.		QTY.	DESCRIPTION
		EFF.	DISC.		
27	366-153			1	KNOB, VAR 10-1, small charcoal
	- - - -			-	Includes:
	213-004			1	SCREW, set, 6-32 x 3/16 inch HSS
	- - - -			-	Mounting Hardware For Miniature Pot:
	210-583			2	NUT, hex, 1/4-32 x 5/16 inch
	210-940			1	WASHER, 1/4 ID x 3/8 inch OD
	210-046			1	LOCKWASHER, internal, .400 OD x .261 inch ID
28	131-106			3	CONNECTOR, chassis mount, 1 contact, BNC
	- - - -			-	Each Includes:
	210-413			1	NUT, hex, 3/8-32 x 1/2 inch
	210-012			1	LOCKWASHER, internal, 3/8 x 1/2 inch
29	366-160			1	KNOB, HORIZONTAL DISPLAY, large charcoal
	- - - -			-	Includes:
	213-004			1	SCREW, set, 6-32 x 3/16 inch HSS
30	366-038			1	KNOB, SWEEP MAGNIFIER, small red
	- - - -			-	Includes:
	213-004			1	SCREW, set, 6-32 x 3/16 inch HSS
31	262-603			1	SWITCH, HORIZONTAL DISPLAY, front, wired
	- - - -			-	Includes:
	260-532			1	SWITCH, unwired
	- - - -			-	Mounting Hardware: (not included)
	210-413			1	NUT, hex, 3/8-32 x 1/2 inch
	210-013			1	LOCKWASHER, internal, 3/8 x 1 1/16 inch
32	262-604			1	SWITCH, HORIZONTAL DISPLAY, rear, wired
	- - - -			-	Includes:
	260-533			1	SWITCH, unwired
33	406-902			1	BRACKET, switch mounting
	- - - -			-	Mounting Hardware: (not included)
	210-413			1	NUT, hex, 3/8-32 x 1/2 inch
	210-840			1	WASHER, .390 ID x 9/16 inch OD
	210-012			1	LOCKWASHER, internal, 3/8 x 1/2 inch
34	406-897			1	BRACKET, trimmer
	- - - -			-	Mounting Hardware: (not included)
	210-406			2	NUT, hex, 4-40 x 3/16 inch
	210-004			2	LOCKWASHER, internal, #4
35	- - - -			-	Mounting Hardware For Each Capacitor:
	213-088			2	SCREW, thread forming, 4-40 x 1/4 inch PHS Phillips
	- - - -			-	Mounting Hardware: (not included)
	211-507			2	SCREW, 6-32 x 5/16 inch BHS
	210-457			2	NUT, keps, 6-32 x 5/16 inch
36	366-117			2	KNOB, TRIGGERING LEVEL, large charcoal
	- - - -			-	Each Includes:
	213-004			1	SCREW, set, 6-32 x 3/16 inch HSS
	- - - -			-	Mounting Hardware For Each Pot:
	210-413			1	NUT, hex, 3/8-32 x 1/2 inch
	210-013			1	LOCKWASHER, internal, 3/8 x 1 1/16 inch
	210-207			1	LUG, solder, 3/8 inch
37	366-220			1	KNOB, SCALE ILLUM., small charcoal
	- - - -			-	Includes:
	213-004			1	SCREW, set, 6-32 x 3/16 inch HSS
38	- - - -			-	Mounting Hardware For Each Pot:
	210-590			1	NUT, hex, 3/8-32 x 7/16 inch
	210-840			1	WASHER, .390 ID x 9/16 inch OD
	210-013			1	LOCKWASHER, internal, 3/8 x 1 1/16 inch
39	366-254			1	KNOB, ASTIGMATISM, small charcoal
	- - - -			-	Includes:
	213-004			1	SCREW, set, 6-32 x 3/16 inch HSS
40	366-220			1	KNOB, FOCUS, small charcoal
	- - - -			-	Includes:
	213-004			1	SCREW, set, 6-32 x 3/16 inch HSS

EXPLODED VIEW (Cont'd.)

REF. NO.	PART NO.	SERIAL NO.		QTY.	DESCRIPTION
		EFF.	DISC.		
41	366-220			1	KNOB, INTENSITY, small charcoal
	- - - -			-	Includes:
	213-004			1	SCREW, set, 6-32 x 3/16 inch HSS
42	366-144			1	KNOB, "A" TIME/CM, large charcoal
	- - - -			-	Includes:
	213-004			1	SCREW, set, 6-32 x 3/16 inch HSS
43	262-595			1	SWITCH, "A" TIME/CM, wired
	- - - -			-	Includes:
	260-530			1	SWITCH, unwired
44	384-288			1	ROD, extension
	376-014			1	COUPLING, pot
45	406-899			1	BRACKET, time/cm switch "A"
	- - - -			-	Mounting Hardware: (not included)
	210-449			2	NUT, hex, 5-40 x 1/4 inch
	210-006			2	LOCKWASHER, internal, #6
	348-003			1	GROMMET, 5/16 inch (not shown)
	- - - -			-	Mounting Hardware For Capacitor: (not shown)
	210-407			3	NUT, hex, 6-32 x 1/4 inch
	210-006			3	LOCKWASHER, internal, #6
	210-803			1	WASHER, 6L x 3/8 inch
46	- - - -			-	Mounting Hardware For Pot:
	210-413			2	NUT, hex, 3/8-32 x 1/2 inch
	210-012			1	LOCKWASHER, internal, 3/8 x 1/2 inch
	210-255			1	LUG, solder
	- - - -			-	Mounting Hardware For Miniature Pot:
	210-583			1	NUT, hex, 1/4-32 x 5/16 inch
	210-046			1	LOCKWASHER, internal, .400 OD x .261 inch ID
47	352-061			1	HOLDER, component
	- - - -			-	Mounting Hardware: (not included)
	211-008			2	SCREW, 4-40 x 1/4 inch BHS
	210-004			2	LOCKWASHER, internal, #4
	210-406			2	NUT, hex, 4-40 x 3/16 inch
	- - - -			-	Mounting Hardware: (not included)
	212-004			3	SCREW, 8-32 x 5/16 inch BHS
	210-804			3	WASHER, 8S x 3/8 inch
	210-413			1	NUT, hex, 3/8-32 x 1/2 inch
	210-013			1	LOCKWASHER, internal, 3/8 x 1 1/16 inch
48	200-382			1	COVER, graticule
	- - - -			-	Includes:
	354-116			1	RING, ornamental
	- - - -			-	Mounting Hardware: (not included)
49	210-424			4	NUT, knurled, 3/8-24 x 7/16 inch
50	387-917			1	PLATE, eyebrow, graticule
51	378-543			1	FILTER, light
52	354-204			1	RING, crt shockmount
53	200-269			2	COVER, pot
54	136-269			2	SOCKET, graticule light
	- - - -			-	Mounting Hardware For Each: (not included)
	211-534			1	SCREW, 6-32 x 5/16 inch PHS with lockwasher
	210-457			1	NUT, keps, 6-32 x 5/16 inch
55	200-534			1	COVER, neon holder
56	378-541			9	FILTER, lens, neon light
57	352-064			3	HOLDER, neon, double
	- - - -			-	Mounting Hardware For Each: (not included)
	211-031			1	SCREW, 4-40 x 1 inch FHS
	210-406			2	NUT, hex, 4-40 x 3/16 inch
58	214-433			1	SPRING, light pipe hold down
59	131-086			1	CONNECTOR, cable, assembly
	- - - -			-	Includes:
	131-073			1	CONNECTOR, crt brush
	200-110			1	CAP, crt anode

EXPLODED VIEW (Cont'd.)

REF. NO.	PART NO.	SERIAL NO.		QTY.	DESCRIPTION
		EFF.	DISC.		
60	200-112			1	COVER, crt anode and plate assembly
	- - - -			-	Consisting Of:
	200-111			1	COVER, crt anode
	386-647			1	PLATE, crt anode
	134-031			1	PLUG, crt contact (not shown)
61	262-597			1	SWITCH, TRIGGERING "A", wired
	- - - -			-	Includes:
	260-493			1	SWITCH, MODE, lever
	- - - -			-	Mounting Hardware: (not included)
	213-088			2	SCREW, thread forming, 4-40 x 1/4 inch PHS phillips
	260-494			1	SWITCH, COUPLING, lever
	- - - -			-	Mounting Hardware: (not included)
	213-088			2	SCREW, thread forming, 4-40 x 1/4 inch PHS phillips
	260-495			1	SWITCH, SOURCE, lever
	- - - -			-	Mounting Hardware: (not included)
	213-088			2	SCREW, thread forming, 4-40 x 1/4 inch PHS phillips
	260-542			1	SWITCH, SLOPE, lever
	- - - -			-	Mounting Hardware: (not included)
	213-088			2	SCREW, thread forming, 4-40 x 1/4 inch PHS phillips
	406-943			1	BRACKET, lever switch
	- - - -			-	Mounting Hardware: (not included)
	210-586			4	NUT, keps, 4-40 x 1/4 inch
	210-201			2	LUG, solder, SE4
62	387-755			1	PLATE, plug-in housing, bottom
	- - - -			-	Mounting Hardware: (not included)
	212-040			2	SCREW, 8-32 x 3/8 inch FHS phillips
	212-004			2	SCREW, 8-32 x 5/16 inch BHS
	210-458			4	NUT, keps, 8-32 x 11/32 inch
63	344-097			2	CLIP, grounding
64	387-754			1	PLATE, plug-in housing, top
	- - - -			-	Mounting Hardware: (not included)
	212-040			2	SCREW, 8-32 x 3/8 inch FHS phillips
	212-010			1	SCREW, 8-32 x 5/16 inch BHS
	212-004			4	SCREW, 8-32 x 5/16 inch BHS
	210-804			3	WASHER, 8S x 3/8 inch
	210-458			4	NUT, keps, 8-32 x 11/32 inch
65	387-761			1	PLATE, cabinet side, left
	- - - -			-	Includes:
	134-027			1	PLUG, steel
	214-361			2	LATCH, quarter turn, assembly
	- - - -			-	Each Consisting Of:
66	214-400			1	PIN, securing, index
	358-218			1	BUSHING, latch bearing
67	387-871			1	PLATE, latch index
68	387-804			1	PLATE, latch locking
69	214-359			1	SPRING, latch
70	406-903			1	BRACKET, push switch mounting
	- - - -			-	Mounting Hardware: (not included)
	211-510			2	SCREW, 6-32 x 3/8 inch BHS
71	260-516			1	SWITCH
	- - - -			-	Mounting Hardware: (not included)
	211-034			2	SCREW, 2-56 x 1/2 inch RHS
	210-001			2	LOCKWASHER, internal, #2
	210-405			2	NUT, hex, 2-56 x 3/16 inch
72	384-270			1	ROD, push switch
	214-333			1	SPRING, push switch rod
73	260-601			1	SWITCH, COMPENSATION, slide
	- - - -			-	Mounting Hardware: (not included)
	211-504			2	SCREW, 6-32 x 1/4 inch BHS
74	366-271			1	KNOB, COMPENSATION, slide

EXPLODED VIEW (Cont'd.)

REF. NO.	PART NO.	SERIAL NO.		QTY.	DESCRIPTION
		EFF.	DISC.		
75	387-753			1	PLATE, plug-in housing, back
	- - - -			-	Mounting Hardware: (not included)
	212-004			4	SCREW, 8-32 x 5/16 inch BHS
	212-023			1	SCREW, 8-32 x 3/8 inch BHS
	210-804			3	WASHER, 8S x 3/8 inch
	212-039			1	SCREW, 8-32 x 3/8 inch THS phillips
	210-458			1	NUT, keps, 8-32 x 11/32 inch
76	351-058			4	GUIDE, shoe
77	122-109			1	ANGLE, rail, top left
	- - - -			-	Mounting Hardware: (not included)
	211-559			4	SCREW, 6-32 x 3/8 inch FHS phillips
	210-457			4	NUT, keps, 6-32 x 5/16 inch
78	406-995			1	BRACKET, support
	- - - -			-	Mounting Hardware
	212-001			4	SCREW, 8-32 x 1/4 inch BHS
	210-458			2	NUT, keps, 8-32 x 11/32 inch
	210-804			2	WASHER, 8S x 3/8 inch
79	- - - -			-	Mounting Hardware For Trace Rotator Coil:
	211-507			3	SCREW, 6-32 x 5/16 inch BHS
	210-457			3	NUT, keps, 6-32 x 5/16 inch
80	337-568			1	SHIELD, crt
	- - - -			-	Mounting Hardware: (not included)
	211-504			4	SCREW, 6-32 x 1/4 inch BHS
81	252-547			FT	VINYL, extruded channel, cushion (8 5/8 inches)
82	354-215			1	RING, crt clamping, assembly
	- - - -			-	Consisting Of:
	354-211			1	RING, clamping
	211-560			1	SCREW, 6-32 x 1 inch RHS
	210-407			1	NUT, hex, 6-32 x 1/4 inch
83	124-160			1	STRIP, liner, crt clamp
84	214-207			1	NUT, adjusting, securing
	- - - -			-	Mounting Hardware: (not included)
	211-576			2	SCREW, 6-32 x 7/8 inch socket head
	210-949			4	WASHER,, 9/64 ID x 1/2 inch OD
85	343-089			10	CLAMP, cable, large
86	348-051			2	GROMMET, 15/16 inch
87	136-168			1	SOCKET, crt, assembly
	- - - -			-	Includes:
	136-117			1	SOCKET, crt, raw
	131-178			8	CONNECTOR, cable end, crt
	387-393			1	PLATE, back, crt socket
	- - - -			-	Mounting Hardware: (not included)
	213-086			2	SCREW, thread cutting, 2-32 x 7/16 inch PHS
88	348-006			5	GROMMET, 3/4 inch
89	406-936			1	BRACKET, crt mounting
	- - - -			-	Mounting Hardware: (not included)
	212-004			1	SCREW, 8-32 x 5/16 inch BHS
	210-804			2	WASHER, 8S x 3/8 inch
	210-457			1	NUT, keps, 8-32 x 11/32 inch
90	406-994			1	BRACKET, crt
	- - - -			-	Mounting Hardware: (not included)
	212-004			5	SCREW, 8-32 x 5/16 inch BHS
	210-804			2	WASHER, 8S x 3/8 inch
	210-457			3	NUT, keps, 8-32 x 11/32 inch
91	358-166			3	BUSHING, plastic, black
92	441-514			1	CHASSIS, sweep deck
	- - - -			-	Mounting Hardware: (not included)
	212-002			4	SCREW, 8-32 x 1/4 inch FHS phillips
	212-004			5	SCREW, 8-32 x 5/16 inch BHS
	210-804			5	WASHER, 8S x 3/8 inch

EXPLODED VIEW (Cont'd.)

REF. NO.	PART NO.	SERIAL NO.		QTY.	DESCRIPTION
		EFF.	DISC.		
93	131-018			1	CONNECTOR, chassis mount, 16 contact, female
	- - - -			-	Mounting Hardware: (not included)
	211-016			2	SCREW, 4-40 x 5/8 inch RHS
	166-107			2	TUBE, spacing, 7/32 inch
	210-004			2	LOCKWASHER, internal, #4
	210-406			2	NUT, hex, 4-40 x 3/16 inch
94	441-475			1	CHASSIS, high voltage
	- - - -			-	Mounting Hardware: (not included)
	212-002			2	SCREW, 8-32 x 1/4 inch FHS phillips
	212-004			2	SCREW, 8-32 x 5/16 inch BHS
	212-008			1	SCREW, 8-32 x 1/2 inch BHS
	210-804			3	WASHER, 8S x 3/8 inch
	210-458			1	NUT, keps, 8-32 x 1 1/32 inch
95	343-013			1	CLAMP, cable, 3/8 inch
	- - - -			-	Mounting Hardware: (not included)
	210-458			1	NUT, keps, 8-32 x 1 1/32 inch
	210-863			1	WASHER, "D" type, #10
	210-804			1	WASHER, 8S x 3/8 inch
96	348-055			5	GROMMET, plastic
97	136-011			1	SOCKET, STM8
	- - - -			-	Mounting Hardware: (not included)
	210-407			2	NUT, hex, 6-32 x 1/4 inch
	210-006			2	LOCKWASHER, internal, #6
98	343-095			1	CLAMP, tube
	- - - -			-	Mounting Hardware: (not included)
	211-008			1	SCREW, 4-40 x 1/4 inch BHS
	210-004			1	LOCKWASHER, internal, #4
	210-406			1	NUT, hex, 4-40 x 3/16 inch
99	385-129			1	ROD, nylon
	- - - -			-	Mounting Hardware: (not included)
	213-104			1	SCREW, thread forming, 6-32 x 3/8 inch THS phillips
100	136-095			35	SOCKET, 4 pin transistor
	- - - -			-	Mounting Hardware For Each: (not included)
	213-113			2	SCREW, thread forming, 2-32 x 5/16 inch RHS phillips
101	426-121			1	HOLDER, toroid
	- - - -			-	Mounting Hardware: (not included)
	361-007			1	SPACER, nylon, .063 inch
102	131-235			4	CONNECTOR, terminal
	- - - -			-	Mounting Hardware For Each: (not included)
	358-136			1	BUSHING, teflon
103	343-003			1	CLAMP, cable, 1/4 inch
	- - - -			-	Mounting Hardware: (not included)
	211-507			1	SCREW, 6-32 x 5/16 inch BHS
	210-863			1	WASHER, "D" type, #10
	210-803			1	WASHER, 6L x 3/8 inch
104	385-024			2	ROD, aluminum
	- - - -			-	Mounting Hardware For Each: (not included)
	211-507			1	SCREW, 6-32 x 5/16 inch BHS
	210-202			1	LUG, solder, SE6
105	- - - -			-	Mounting Hardware For Capacitor:
	213-088			2	SCREW, thread forming, 4-40 x 1/4 inch PHS phillips
106	- - - -			-	Mounting Hardware For Each Coil:
	213-088			1	SCREW, thread forming, 4-40 x 1/4 inch PHS phillips
107	210-201			22	LUG, solder, SE4
	- - - -			-	Mounting Hardware For Each: (not included)
	213-044			1	SCREW, thread forming, 5-32 x 3/16 inch PHS phillips
108	136-015			25	SOCKET, STM9G
	- - - -			-	Mounting Hardware For Each: (not included)
	213-044			2	SCREW, thread forming, 5-32 x 3/16 inch PHS phillips

EXPLODED VIEW (Cont'd.)

REF. NO.	PART NO.	SERIAL NO.		QTY.	DESCRIPTION
		EFF.	DISC.		
109	119-030			1	DELAY LINE, assembly
	- - - -			-	Includes:
	380-049			1	HOUSING, delay line
	200-482			1	COVER, delay line housing
	131-271			2	CONNECTOR, right hand
	211-510			1	SCREW, 6-32 x $\frac{3}{8}$ inch BHS
	211-513			1	SCREW, 6-32 x $\frac{5}{8}$ inch BHS
	211-517			4	SCREW, 6-32 x 1 inch BHS
	210-202			1	LUG, solder, SE6
	210-407			10	NUT, hex, 6-32 x $\frac{1}{4}$ inch
	- - - -			-	Mounting Hardware: (not included)
	210-457			4	NUT, keps, 6-32 x $\frac{5}{16}$ inch
110	214-317			2	HEAT SINK, insulator disc
	- - - -			-	Mounting Hardware For Each: (not included)
111	352-062			1	HOLDER, transistor heat sink
112	343-097			1	CLAMP, transistor heat sink
	211-008			2	SCREW, 4-40 x $\frac{1}{4}$ inch BHS
	211-012			2	SCREW, 4-40 x $\frac{3}{8}$ inch BHS
	210-406			4	NUT, hex, 4-40 x $\frac{3}{16}$ inch
	210-599			2	NUT, sleeve
	214-368			1	SPRING, transistor heat sink holder
	210-627			1	RIVET
113	670-401			1	BOARD, printed circuit, upper vertical amplifier
	- - - -			-	Includes:
114	136-150			6	SOCKET, 3 pin transistor
115	343-088			1	CLAMP, cable, small
	- - - -			-	Mounting Hardware: (not included)
	211-507			4	SCREW, 6-32 x $\frac{5}{16}$ inch BHS
	210-801			4	WASHER, 5S x $\frac{9}{32}$ inch
116	129-069			4	POST, capacitor tie
	- - - -			-	Mounting Hardware For Each: (not included)
	361-007			1	SPACER, nylon, .063 inch
117	441-476			1	CHASSIS, output vertical amplifier
	- - - -			-	Mounting Hardware: (not included)
	212-004			2	SCREW, 8-32 x $\frac{5}{16}$ inch BHS
	210-804			2	WASHER, 8S x $\frac{3}{8}$ inch
	210-458			4	NUT, keps, 8-32 x $\frac{11}{32}$ inch
118	131-335			1	CONNECTOR, deflector lead, assembly, brown
	131-336			1	CONNECTOR, deflector lead, assembly, blue
	175-588			1	WIRE, crt lead, .833 foot, striped orange, with connector
	175-592			1	WIRE, crt lead, .960 foot, striped green, with connector
	175-595			1	WIRE, crt lead, .960 foot, striped red, with connector
119	343-088			3	CLAMP, cable, small
120	- - - -			-	Mounting Hardware For Each Miniature Pot:
	210-583			1	NUT, hex, $\frac{1}{4}$ -32 x $\frac{5}{16}$ inch
	210-940			1	WASHER, $\frac{1}{4}$ ID x $\frac{3}{8}$ inch OD
121	348-004			7	GROMMET, $\frac{3}{8}$ inch
122	355-043			4	STUD, graticule, replacement: (not shown)
	- - - -			-	Each Includes:
	212-507			1	SCREW, 10-32 x $\frac{3}{8}$ inch BHS
	210-010			1	LOCKWASHER, internal, #10
123	200-532			1	COVER, capacitor
124	432-047			1	BASE, small capacitor mounting
	- - - -			-	Mounting Hardware: (not included)
	211-588			2	SCREW, 6-32 x $\frac{3}{4}$ inch HHS
	210-006			2	LOCKWASHER, internal, #6
	210-407			2	NUT, hex, 6-32 x $\frac{1}{4}$ inch
	386-252			1	PLATE, fiber, small capacitor
125	210-204			11	LUG, solder, DE6
	- - - -			-	Mounting Hardware For Each: (not included)
	213-044			1	SCREW, thread cutting, 5-32 x $\frac{3}{16}$ inch PHS phillips

EXPLODED VIEW (Cont'd.)

REF. NO.	PART NO.	SERIAL NO.		QTY.	DESCRIPTION
		EFF.	DISC.		
126	432-048			3	BASE, large capacitor mounting
	- - - -			-	Mounting Hardware For Each: (not included)
	211-588			2	SCREW, 6-32 x 3/4 inch HHS
	210-006			2	LOCKWASHER, internal, #6
	210-407			2	NUT, hex, 6-32 x 1/4 inch
	386-255			3	PLATE, metal, large capacitor
127	- - - -			-	Mounting Hardware For Each 25 Watt Resistor:
	212-037			1	SCREW, 8-32 x 1 3/4 inches Fil HS
	210-008			1	LOCKWASHER, internal, #8
	210-809			1	WASHER, resistor centering
	210-462			1	NUT, hex, resistor mounting
	212-004			1	SCREW, 8-32 x 5/16 inch BHS
128	- - - -			-	Mounting Hardware For Each 10 Watt Resistor:
	211-553			1	SCREW, 6-32 x 1 1/2 inches RHS phillips
	210-601			1	EYELET
	210-478			1	NUT, hex, resistor mounting
	211-507			1	SCREW, 6-32 x 5/16 inch BHS
129	- - - -			-	Mounting Hardware For Each 5 Watt Resistor:
	211-544			1	SCREW, 6-32 x 3/4 inch THS phillips
	210-478			1	NUT, hex, resistor mounting
	211-507			1	SCREW, 6-32 x 5/16 inch BHS
130	432-047			1	BASE, small capacitor mounting
	- - - -			-	Mounting Hardware: (not included)
	211-514			2	SCREW, 6-32 x 3/4 inch BHS
	210-006			2	LOCKWASHER, internal, #6
	210-407			2	NUT, hex, 6-32 x 1/4 inch
	386-253			1	PLATE, metal, small capacitor
131	348-002			2	GROMMET, 1/4 inch
132	348-005			6	GROMMET, 1/2 inch
133	380-048			1	HOUSING, high voltage
	- - - -			-	Mounting Hardware: (not included)
	211-507			3	SCREW, 6-32 x 5/16 inch BHS
134	- - - -			-	Mounting Hardware For High Voltage Transformer:
	211-521			2	SCREW, 6-32 x 1 1/2 inches RHS
	210-801			2	WASHER, 5S x 7/32 inch
	358-228			2	BUSHING, insulator
135	166-319			2	SLEEVE, high voltage
136	337-566			1	SHIELD, high voltage
	- - - -			-	Mounting Hardware: (not included)
	211-504			4	SCREW, 6-32 x 1/4 inch BHS
	211-541			1	SCREW, 6-32 x 1/4 inch FHS phillips
137	210-261			2	LUG, solder, high voltage
	- - - -			-	Mounting Hardware: (not included)
	211-587			1	SCREW, 6-32 x 7/32 inch HHS
138	200-475			1	COVER, high voltage
	- - - -			-	Mounting Hardware: (not included)
139	211-521			2	SCREW, 6-32 x 1 1/2 inches RHS
	210-801			2	WASHER, 5S x 7/32 inch
140	166-357			1	SLEEVE, high voltage anode lead
141	392-147			1	BOARD, high voltage, with ceramic strips
	- - - -			-	Mounting Hardware: (not included)
	211-507			1	SCREW, 6-32 x 5/16 inch BHS
142	210-966			2	WASHER, insulating, rubber, 7/8 OD x 7/16 inch ID
143	384-542			2	ROD, capacitor mounting
	- - - -			-	Mounting Hardware For Each: (not included)
	211-507			1	SCREW, 6-32 x 5/16 inch BHS
144	385-170			1	ROD, spacer, nylon
	- - - -			-	Mounting Hardware: (not included)
	213-041			1	SCREW, thread cutting, 6-32 x 3/8 inch THS phillips
145	337-594			1	SHIELD, horizontal preamplifier
	- - - -			-	Mounting Hardware: (not included)
	211-504			2	SCREW, 6-32 x 1/4 inch BHS

EXPLODED VIEW (Cont'd.)

REF. NO.	PART NO.	SERIAL NO.		QTY.	DESCRIPTION
		EFF.	DISC.		
146	129-072			1	POST, diode tie-off
	- - - -			-	Includes:
	131-309			1	CONNECTOR, terminal
	- - - -			-	Mounting Hardware: (not included)
	361-007			1	SPACER, nylon, .063 inch
147	136-013			2	SOCKET, STM8
	- - - -			-	Mounting Hardware For Each: (not included)
	210-407			2	NUT, hex, 6-32 x 1/4 inch
	210-006			2	LOCKWASHER, internal, #6
148	214-435			2	HEAT SINK, transistor
149	- - - -			-	Mounting Hardware For Each Miniature Pot:
	210-471			1	NUT, hex, 1/4-32 x 5/16 inch x 19/32 inch
	210-046			1	LOCKWASHER, internal, .400 OD x .261 inch ID
	358-054			1	BUSHING, banana jack
150	337-588			1	SHIELD, sweep generator
	- - - -			-	Mounting Hardware: (not included)
	211-504			2	SCREW, 6-32 x 1/4 inch BHS
151	136-008			7	SOCKET, STM7G
	- - - -			-	Mounting Hardware For Each: (not included)
	213-044			2	SCREW, thread cutting, 5-32 x 3/16 inch PHS phillips
152	- - - -			-	Mounting Hardware For Each Pot
	210-413			1	NUT, hex, 3/8 x 1/2 inch
	210-840			1	WASHER, .390 ID x 9/16 inch OD
	210-012			1	LOCKWASHER, internal, 3/8 x 1/2 inch
	210-207			1	LUG, solder, 3/8 inch
153	348-031			14	GROMMET, poly snap-in
154	385-134			3	ROD, delrin
	- - - -			-	Mounting Hardware For Each: (not included)
	213-104			1	SCREW, thread forming, 6-32 x 3/8 inch THS phillips
155	432-047			1	BASE, small capacitor mounting
	- - - -			-	Mounting Hardware: (not included)
	211-588			2	SCREW, 6-32 x 3/4 inch HHS
	210-006			2	LOCKWASHER, internal, #6
	210-407			2	NUT, hex, 6-32 x 1/4 inch
	386-253			1	PLATE, metal, small capacitor
156	384-613			1	ROD, anchor
	- - - -			-	Includes:
157	134-033			2	PLUG, banana, male, push in type
158	214-370			1	PIN, locating
	- - - -			-	Mounting Hardware: (not included)
	212-004			2	SCREW, 8-32 x 5/16 inch BHS
	210-804			2	WASHER, 8S x 3/8 inch
159	337-008			1	SHIELD, tube
160	376-007			1	COUPLING
	- - - -			-	Includes:
	213-005			2	SCREW, set, 8-32 x 1/8 inch HSS
161	262-602			1	SWITCH, SWEEP NORMAL, wired
	- - - -			-	Includes:
	260-496			1	SWITCH, unwired
162	260-516			1	SWITCH, RESET, push
	- - - -			-	Mounting Hardware: (not included)
	211-034			2	SCREW, 2-56 x 1/2 inch RHS
	210-850			2	WASHER, #2 flat
	210-001			2	LOCKWASHER, internal, #2
	210-405			2	NUT, hex, 2-56 x 3/16 inch
	- - - -			-	Mounting Hardware: (not included)
	210-586			2	NUT, keps, 4-40 x 1/4 inch
163	343-005			1	CLAMP, cable, 7/16 inch
	- - - -			-	Mounting Hardware: (not included)
	210-457			1	NUT, keps, 6-32 x 5/16 inch
	210-863			1	WASHER, "D" type, #10

EXPLODED VIEW (Cont'd.)

REF. NO.	PART NO.	SERIAL NO.		QTY.	DESCRIPTION
		EFF.	DISC.		
164	385-170			1	ROD, spacer, nylon
	- - - -			-	Mounting Hardware: (not included)
	213-068			1	SCREW, thread cutting, 6-32 x 5/16 inch FHS phillips
165	387-756			1	PLATE, cabinet, bottom
	- - - -			-	Includes:
	214-361			4	LATCH, quarter turn, assembly
	- - - -			-	Each Consisting Of:
	214-400			1	PIN, securing index
	358-218			1	BUSHING, latch bearing
	387-871			1	PLATE, latch index
	387-804			1	PLATE, latch locking
	214-359			1	SPRING, latch
166	122-108			2	ANGLE, rail, bottom
	- - - -			-	Mounting Hardware For Each: (not included)
	212-039			4	SCREW, 8-32 x 3/8 inch THS phillips
	210-458			4	NUT, keps, 8-32 x 1 1/32 inch
167	387-759			1	PLATE, vertical bulkhead
	- - - -			-	Mounting Hardware: (not included)
	212-040			4	SCREW, 8-32 x 3/8 inch FHS phillips
	210-458			4	NUT, keps, 8-32 x 1 1/32 inch
	212-001			3	SCREW, 8-32 x 1/4 inch BHS
	212-004			2	SCREW, 8-32 x 5/16 inch BHS
	210-804			5	WASHER, 8S x 3/8 inch
168	441-478			1	CHASSIS, power
	- - - -			-	Mounting Hardware: (not included)
	212-040			5	SCREW, 8-32 x 3/8 inch FHS phillips
	210-458			5	NUT, keps, 8-32 x 1 1/32 inch
	212-001			7	SCREW, 8-32 x 1/4 inch BHS
	210-804			7	WASHER, 8S x 3/8 inch
169	337-574			1	SHIELD, calibrator switch
	- - - -			-	Mounting Hardware: (not included)
	211-504			1	SCREW, 6-32 x 1/4 inch BHS
	210-803			1	WASHER, 6L x 3/8 inch
	210-457			1	NUT, keps, 6-32 x 5/16 inch
170	136-022			1	SOCKET, STM9, shielded
	- - - -			-	Mounting Hardware: (not included)
	213-044			2	SCREW, thread cutting, 5-32 x 3/16 inch PHS phillips
171	- - - -			-	Mounting Hardware For Thermal Cutout:
	213-044			2	SCREW, thread cutting, 5-32 x 3/16 inch PHS phillips
172	406-023			2	BRACKET, pot
	- - - -			-	Mounting Hardware For Each: (not included)
	211-507			2	SCREW, 6-32 x 5/16 inch BHS
	210-006			2	LOCKWASHER, internal, #6
	210-407			2	NUT, hex, 6-32 x 1/4 inch
173	- - - -			-	Mounting Hardware For Pot:
	210-444			1	NUT, hex, 3/8-32 x 1/2 x 5/8 inch long
	210-840			1	WASHER, .390 ID x 9/16 inch OD
	210-012			1	LOCKWASHER, internal, 3/8 x 1/2 inch
174	348-003			5	GROMMET, 5/16 inch
175	210-259			1	LUG, solder, #2
	- - - -			-	Mounting Hardware: (not included)
	213-055			1	SCREW, thread cutting, 2-32 x 3/16 inch PHS phillips
176	441-474			1	CHASSIS, delayed sweep
	- - - -			-	Includes:
177	214-329			2	FASTENER, screw
178	131-269			2	CONNECTOR, receptacle
179	358-214			2	BUSHING, insulator
	- - - -			-	Mounting Hardware: (not included)
	212-008			3	SCREW, 8-32 x 1/2 inch BHS
180	210-255			1	LUG, solder, pot

EXPLODED VIEW (Cont'd.)

REF. NO.	PART NO.	SERIAL NO.		QTY.	DESCRIPTION
		EFF.	DISC.		
181	381-215			1	BAR, stop
	- - - -			-	Mounting Hardware: (not included)
	212-008			1	SCREW, 8-32 x 1/2 inch BHS
182	387-762			1	PLATE, cabinet, right side
	- - - -			-	Includes:
	214-361			2	LATCH, quarter turn, assembly
	- - - -			-	Each Consisting Of:
	214-400			1	PIN, securing, index
	358-218			1	BUSHING, latch bearing
	387-871			1	PLATE, latch index
	387-804			1	PLATE, latch locking
	214-359			1	SPRING, latch
183	384-614			1	ROD, chassis hinge
	- - - -			-	Mounting Hardware: (not included)
184	361-052			1	SPACER, hinge pin
	212-010			1	SCREW, 8-32 x 5/8 inch BHS
185	358-042			1	BUSHING, nylon
186	343-003			1	CLAMP, cable, 1/4 inch
	- - - -			-	Mounting Hardware: (not included)
	212-008			1	SCREW, 8-32 x 5/8 inch BHS
	210-863			1	WASHER, "D" type, #10
187	406-928			1	BRACKET, transformer
	- - - -			-	Mounting Hardware: (not included)
	210-564			2	NUT, hex, 10-32 x 3/8 inch
	210-010			2	LOCKWASHER, internal, #10
188	381-221			2	BAR, transformer support
	- - - -			-	Mounting Hardware For Each: (not included)
	212-033			2	SCREW, 8-32 x 3/4 inch BHS
	210-458			2	NUT, keps, 8-32 x 1 1/32 inch
	212-509			1	SCREW, 10-32 x 5/8 inch BHS
	212-534			1	SCREW, 10-32 x 1 inch BHS
	210-010			2	LOCKWASHER, internal, #10
189	348-012			1	GROMMET, 5/8 inch
190	- - - -			-	Mounting Hardware For Transformer:
	212-524			4	SCREW, 10-32 x 3 1/4 inches HHS
	210-812			4	WASHER, fiber, #10
	210-010			4	LOCKWASHER, internal, #10
	210-564			2	NUT, hex, 10-32 x 3/8 inch
191	384-612			2	ROD, transformer standoff
192	202-102			1	CAN, relay cover
	- - - -			-	Mounting Hardware: (not included)
	210-457			2	NUT, keps, 6-32 x 5/16 inch
193	426-193			1	MOUNT, fan motor
	- - - -			-	Mounting Hardware: (not included)
	212-039			4	SCREW, 8-32 x 3/8 inch THS phillips
194	147-026			1	MOTOR, fan
	- - - -			-	Mounting Hardware: (not included)
	210-458			4	NUT, keps, 8-32 x 1 1/32 inch
195	214-210			1	SPOOL, solder, assembly
	- - - -			-	Includes:
	214-209			1	SPOOL, solder
	- - - -			-	Mounting Hardware: (not included)
	361-007			1	SPACER, nylon, .063 inch
196	369-007			1	FAN, 7 inch
197	200-537			1	COVER, large capacitor
198	200-259			1	COVER, large capacitor
199	432-048			2	BASE, large capacitor mounting
	- - - -			-	Mounting Hardware For Each: (not included)
	211-588			2	SCREW, 6-32 x 3/4 inch HHS
	210-006			2	LOCKWASHER, internal, #6
	210-407			2	NUT, hex, 6-32 x 1/4 inch
	386-254			2	PLATE, fiber, large, capacitor

EXPLODED VIEW (Cont'd.)

REF. NO.	PART NO.	SERIAL NO.		QTY.	DESCRIPTION
		EFF.	DISC.		
200	387-758			1	PLATE, rear sub-pannel
	- - - -			-	Includes:
	354-056			1	RING, ornamental
201	387-766			1	PLATE, rear overlay
	- - - -			-	Mounting Hardware: (not included)
	213-104			4	SCREW, thread forming, 6-32 x 3/8 inch THS phillips
202	334-649			1	TAG, voltage rating
	- - - -			-	Mounting Hardware: (not included)
	213-088			2	SCREW, thread forming, 4-40 x 1/4 inch PHS phillips
203	- - - -			-	Mounting Hardware For 20 Watt Resistor:
	212-037			1	SCREW, 8-32 x 1 3/4 inches Fil HS
	210-808			1	WASHER, resistor centering
	210-462			1	NUT, hex, resistor mounting
	212-004			1	SCREW, 8-32 x 5/16 inch BHS
204	352-002			1	HOLDER, fuse, assembly
	- - - -			-	Consisting Of:
	352-010			1	HOLDER, fuse
	200-015			1	CAP, fuse
	210-873			1	WASHER, rubber, 1/2 ID x 1 1/16 inch OD
	NO NUMBER			1	NUT, fuse holder
205	131-150			1	CONNECTOR, chassis mount, motor base
	- - - -			-	Consisting Of:
	129-041			1	POST, ground, 4-40 thread one end
	200-185			1	COVER, 3 wire motor base
	205-014			1	SHELL, mounting
	210-003			2	LOCKWASHER, external, #4
	210-551			2	NUT, hex, 4-40 x 1/4 inch
	211-015			1	SCREW, 4-40 x 1/2 inch RHS
	214-078			2	PIN, connecting
	377-041			1	INSERT, black urea
	- - - -			-	Mounting Hardware: (not included)
	213-104			2	SCREW, thread forming, 6-32 x 3/8 inch THS phillips
206	378-023			1	FILTER, air, foam
207	387-762			1	SCREEN, filter
	- - - -			-	Mounting Hardware: (not included)
	213-104			4	SCREW, thread forming, 6-32 x 3/8 inch THS phillips
208	406-910			1	BRACKET, shunt resistor
	- - - -			-	Mounting Hardware: (not included)
	211-537			4	SCREW, 6-32 x 3/8 inch THS phillips
209	122-019			1	ANGLE, frame, top right
	- - - -			-	Mounting Hardware: (not included)
	211-559			4	SCREW, 6-32 x 3/8 inch FHS phillips
	210-457			4	NUT, keps, 6-32 x 5/16 inch
210	380-018			1	HOUSING, air filter
	- - - -			-	Mounting Hardware: (not included)
	212-031			2	SCREW, 8-32 x 1 1/4 inches RHS
	210-458			2	NUT, keps, 8-32 x 1 1/32 inch
	210-402			2	NUT, cap, hex, 8-32 x 5/16 inch
211	131-206			1	CONNECTOR, probe power
	- - - -			-	Mounting Hardware: (not included)
	210-559			1	NUT, hex, 7/16-28 x 9/16 inch
	210-021			1	LOCKWASHER, internal
	210-260			1	LUG, solder
212	260-209			1	SWITCH, CRT CATHODE SELECTOR, toggle
	- - - -			-	Mounting Hardware: (not included)
	210-473			1	NUT, switch, 15/32-32 x 5/64 inch
	210-902			1	WASHER, .470 ID x 2 1/32 inch OD
	210-414			1	NUT, hex, 15/32-32 x 9/16 inch
213	387-853			1	PLATE, binding post mounting

EXPLODED VIEW (Cont'd.)

REF. NO.	PART NO.	SERIAL NO.		QTY.	DESCRIPTION
		EFF.	DISC.		
214	129-064			1	POST, binding
	- - - -			-	Mounting Hardware: (not included)
	210-457			1	NUT, keps 6-32 x 5/16 inch
215	346-027			1	STRAP, ground
216	381-217			1	BAR, top support, with handle
	- - - -			-	Includes:
217	344-098			4	CLIP, handle
	212-507			4	SCREW, 10-32 x 3/8 inch BHS
	210-010			4	LOCKWASHER, internal, #10
218	367-037			2	HANDLE
	- - - -			-	Mounting Hardware: (not included)
219	381-073			2	BAR, retaining
	212-039			4	SCREW, 8-32 x 3/8 inch THS phillips
220	- - - -			-	Mounting Hardware For Relay:
	211-503			2	SCREW, 6-32 x 3/16 inch BHS
221	441-473			1	CHASSIS, vertical amplifier
	- - - -			-	Mounting Hardware: (not included)
	212-004			3	SCREW, 8-32 x 5/16 inch BHS
	210-804			3	WASHER, 8S x 3/8 inch
	212-040			1	SCREW, 8-32 x 3/8 inch FHS phillips
	210-458			1	NUT, keps, 8-32 x 1 1/32 inch

CABLE HARNESS AND CERAMIC STRIP DETAIL

POWER CHASSIS

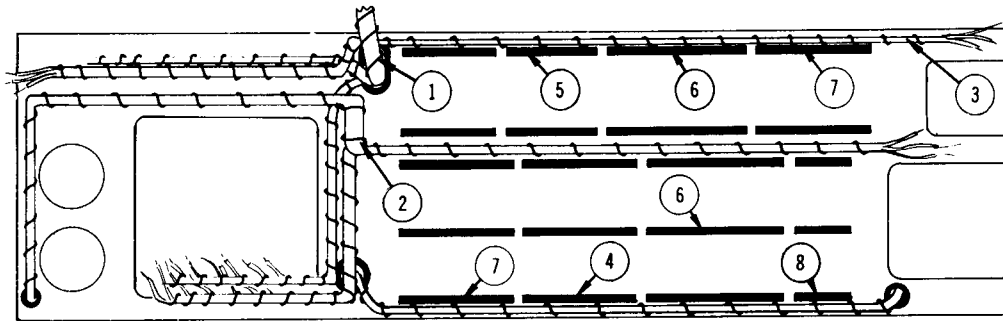

SWEEP "A" CHASSIS

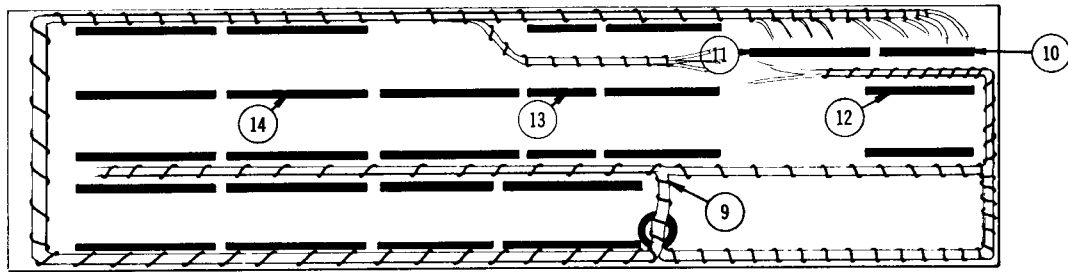

HIGH VOLTAGE CHASSIS

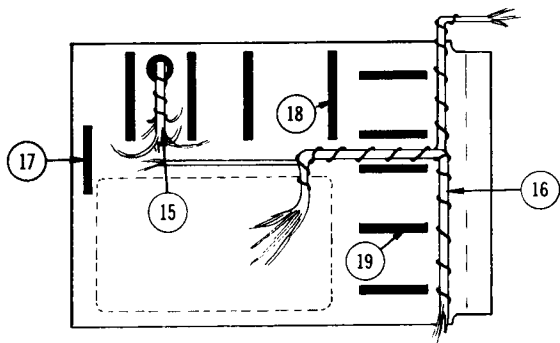

SWEEP "B" CHASSIS

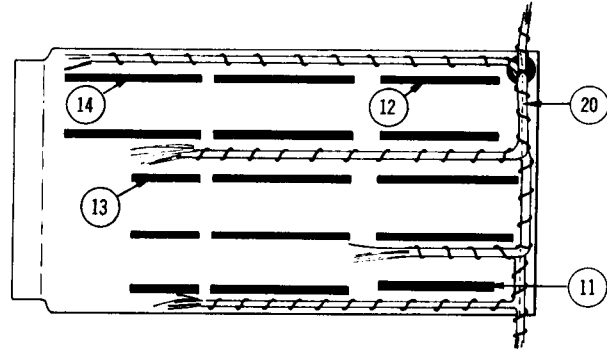

LOWER VERTICAL AMPLIFIER CHASSIS

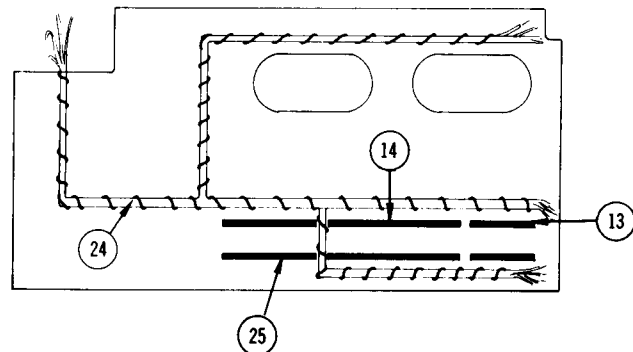

HIGH VOLTAGE

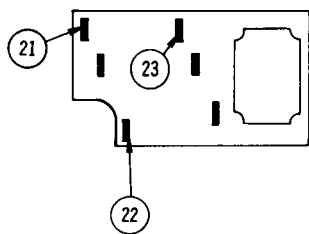

CABLE HARNESS AND CERAMIC STRIP DETAIL

REF. NO.	PART NO.	SERIAL NO.		QTY.	DESCRIPTION
		EFF.	DISC.		
1	179-771			1	CABLE HARNESS, inter-connecting
2	179-761			1	CABLE HARNESS, power
3	179-765			1	CABLE HARNESS, 110 volt
4	179-764			1	CABLE HARNESS, —150 volt adjustment
5	124-089			5	STRIP, ceramic, 3/4 inch x 7 notches
	- - - -			-	Each Includes:
	355-046			2	STUD, nylon
	- - - -			-	Mounting Hardware For Each: (not included)
	361-009			2	SPACER, nylon, .313 inch
6	124-091			6	STRIP, ceramic, 3/4 inch x 11 notches
	- - - -			-	Each Includes:
	355-046			2	STUD, nylon
	- - - -			-	Mounting Hardware For Each: (not included)
	361-009			2	SPACER, nylon, .313 inch
7	124-090			8	STRIP, ceramic, 3/4 inch x 9 notches
	- - - -			-	Each Includes:
	355-046			2	STUD, nylon
	- - - -			-	Mounting Hardware For Each: (not included)
	361-009			2	SPACER, nylon, .313 inch
8	124-088			8	STRIP, ceramic, 3/4 inch x 4 notches
	- - - -			-	Each Includes:
	355-046			2	STUD, nylon
	- - - -			-	Mounting Hardware For Each: (not included)
	361-009			2	SPACER, nylon, .313 inch
9	179-804			1	CABLE HARNESS, "A" sweep
10	124-094			1	STRIP, ceramic, 7/16 inch x 7 notches
	- - - -			-	Includes:
	355-046			2	STUD, nylon
	- - - -			-	Mounting Hardware For Each: (not included)
	361-009			2	SPACER, nylon, .313 inch
11	124-095			2	STRIP, ceramic, 7/16 inch x 9 notches
	- - - -			-	Each Includes:
	355-046			2	STUD, nylon
	- - - -			-	Mounting Hardware For Each: (not included)
	361-009			2	SPACER, nylon, .313 inch
12	124-155			9	STRIP, ceramic, 7/16 inch x 16 notches
	- - - -			-	Each Includes:
	355-082			2	STUD, nylon
	- - - -			-	Mounting Hardware For Each: (not included)
	361-039			2	SPACER, nylon, 11/32 inch
13	124-157			8	STRIP, ceramic, 7/16 inch x 3 notches
	- - - -			-	Each Includes:
	355-082			2	STUD, nylon
	- - - -			-	Mounting Hardware For Each: (not included)
	361-039			2	SPACER, nylon, 11/32 inch
14	124-154			25	STRIP, ceramic, 7/16 inch x 20 notches
	- - - -			-	Each Includes:
	355-082			2	STUD, nylon
	- - - -			-	Mounting Hardware For Each: (not included)
	361-039			2	SPACER, nylon, 11/32 inch
15	179-769			1	CABLE HARNESS, focus and intensity
16	179-767			1	CABLE HARNESS, high voltage
17	124-120			1	STRIP, ceramic, 7/16 inch x 4 notches
	- - - -			-	Includes:
	355-046			2	STUD, nylon
	- - - -			-	Mounting Hardware For Each: (not included)
	361-008			2	SPACER, nylon, .188 inch
18	124-089			4	STRIP, ceramic, 3/4 inch x 7 notches
	- - - -			-	Each Includes
	355-046			2	STUD, nylon
	- - - -			-	Mounting Hardware For Each: (not included)
	361-008			2	SPACER, nylon, .188 inch

CABLE HARNESS AND CERAMIC STRIP DETAIL (Cont'd.)

REF. NO.	PART NO.	SERIAL NO.		QTY.	DESCRIPTION
		EFF.	DISC.		
19	124-093			5	STRIP, ceramic, $\frac{7}{16}$ inch x 5 notches
	- - - -			-	Each Includes:
	355-046			2	STUD, nylon
	- - - -			-	Mounting Hardware For Each: (not included)
	361-009			2	SPACER, nylon, .313 inch
20	179-763			1	CABLE HARNESS, "B" sweep
21	124-164			2	STRIP, ceramic, 4 notches
22	124-163			4	STRIP, ceramic, 2 notches
23	124-162			1	STRIP, ceramic, $\frac{7}{16}$ inch x 4 notches
	- - - -			-	Includes:
	355-046			2	STUD, nylon
	- - - -			-	Mounting Hardware: (not included)
	361-007			1	SPACER, nylon, .063 inch
24	179-770			1	CABLE HARNESS, lower vertical amplifier
25	124-156			2	STRIP, ceramic, $\frac{7}{16}$ inch x 13 notches
	- - - -			-	Each Includes:
	355-082			2	STUD, nylon
	- - - -			-	Mounting Hardware For Each: (not included)
	361-039			2	STUD, nylon, $\frac{1}{32}$ inch

ACCESSORIES

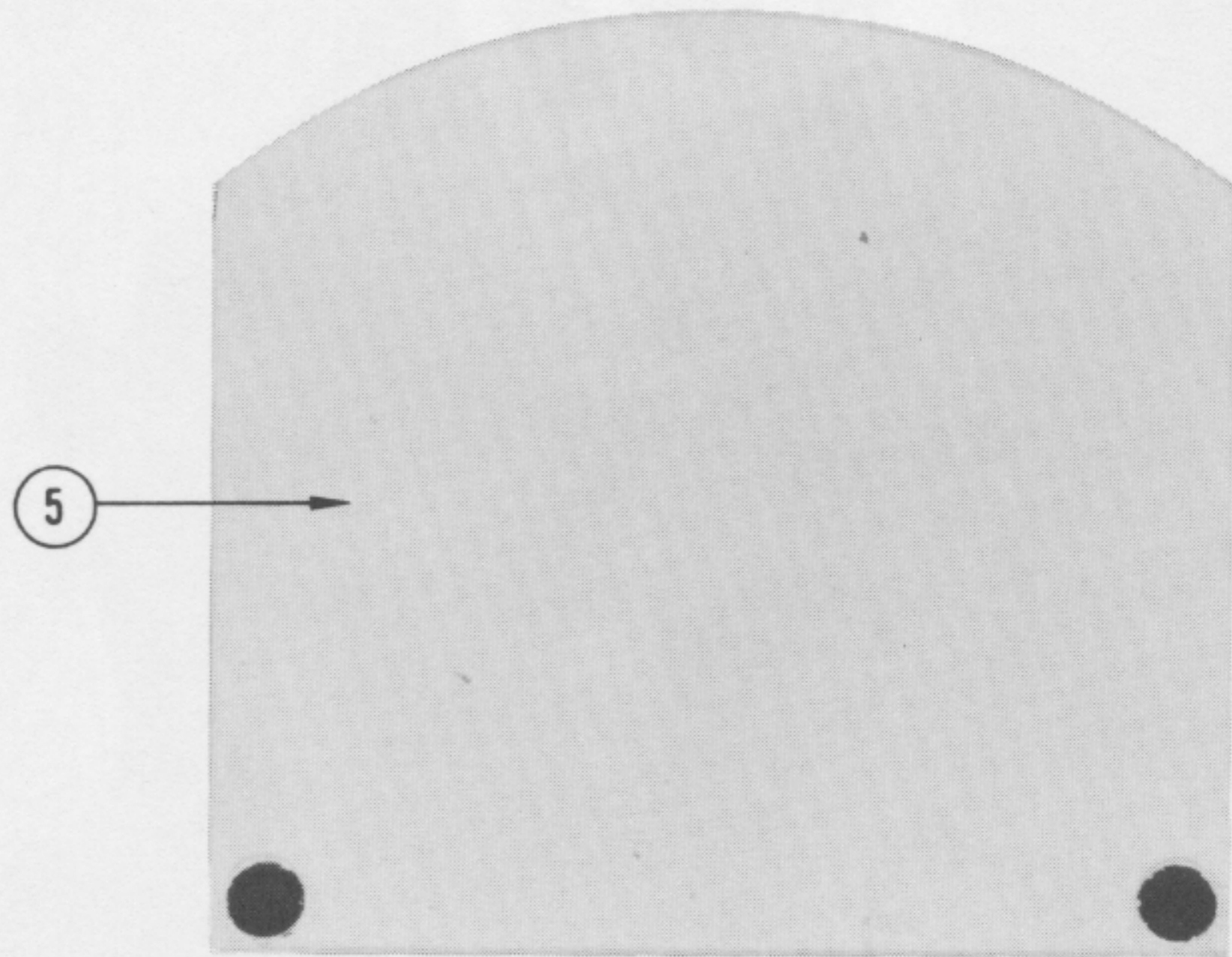
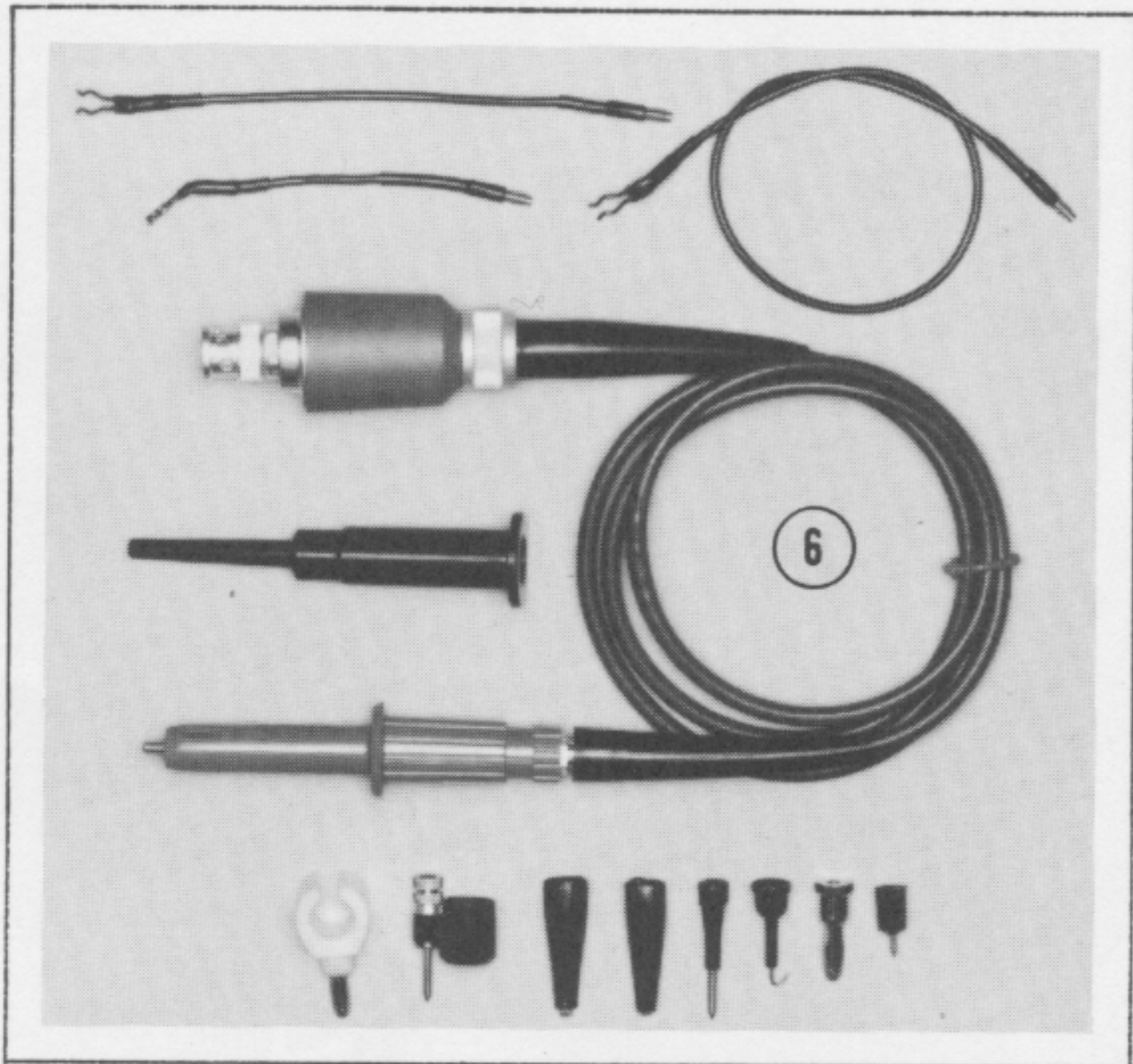
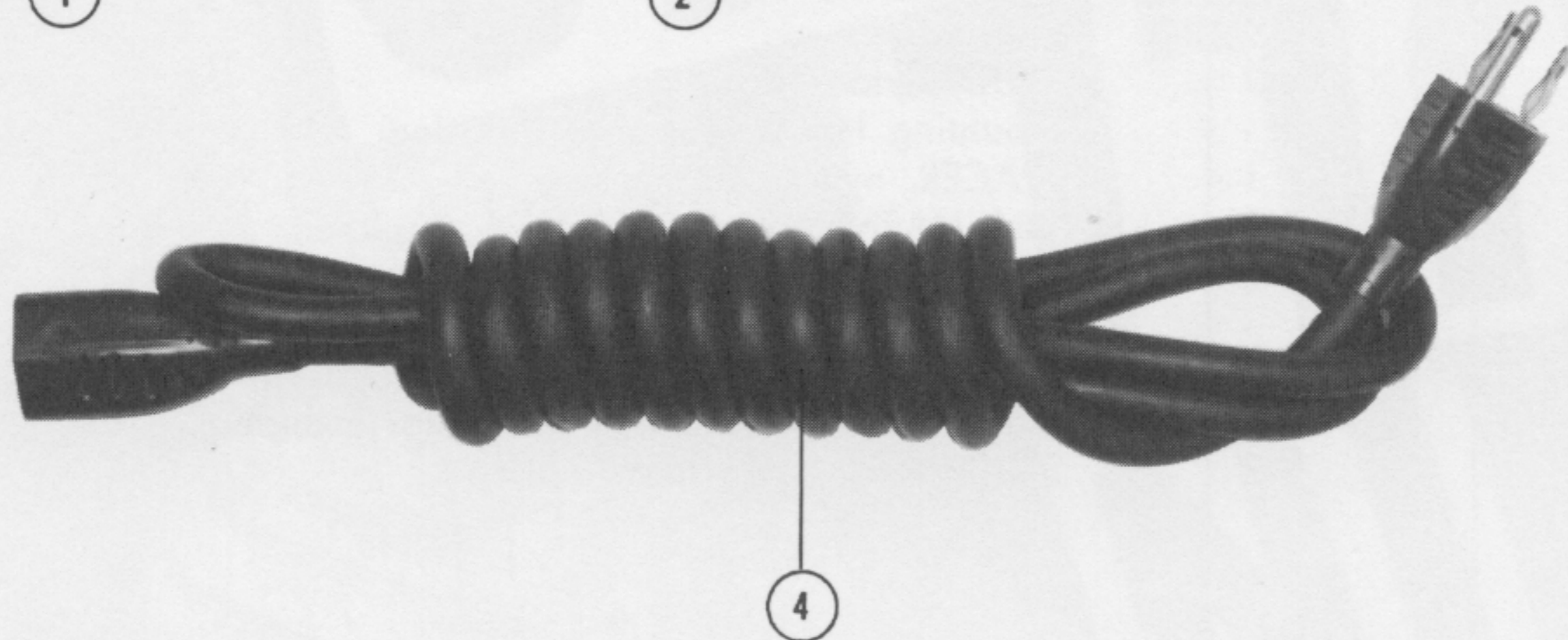
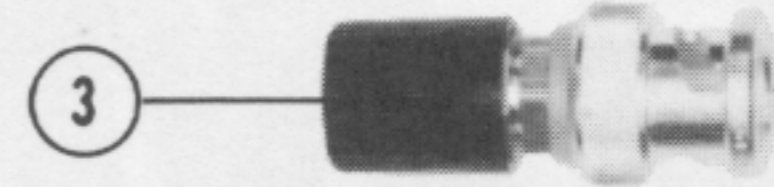
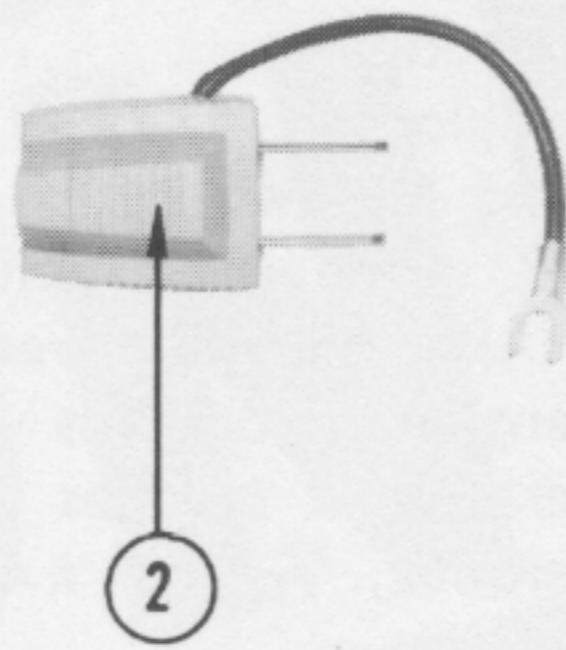
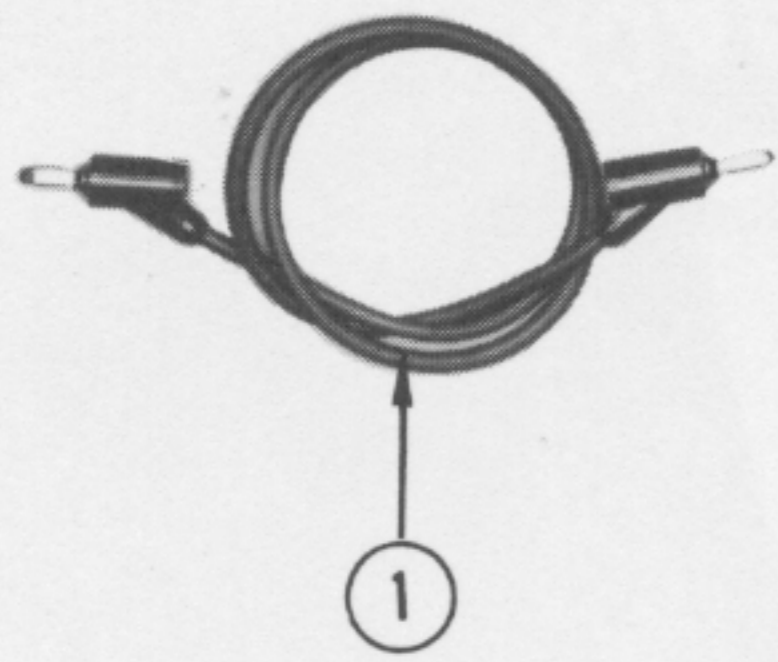

REF. NO.	PART NO	SERIAL NO.		QTY.	DESCRIPTION
		EFF.	DISC.		
1	012-031			2	CORD, patch-banana plug
2	103-013			1	ADAPTER, power cord
3	103-033			3	ADAPTER, BNC to binding post
4	161-010			1	CORD, power
5	389-918			1	PLATE, protector
6	010-129			1	PROBE, package, P6008
	- - - -			-	Includes:
	010-030			1	PROBE, only, P6008

ELECTRICAL PARTS

Values are fixed unless marked Variable.

Ckt. No.	Tektronix Part No.	Description	S/N Range
Bulbs			
B89	150-030	Neon, NE-2 V	READY
B90W	150-030	Neon, NE-2 V	UNCALIBRATED
B94	150-027	Neon, NE-23	
B289	150-030	Neon, NE-2 V	READY
B290W	150-030	Neon, NE-2 V	UNCALIBRATED
B294	150-027	Neon, NE-23	
B550	150-030	Neon, NE-2 V	MAG ON
B579	150-037	Neon, ST2-27S	
B583	150-027	Neon, NE-23	
B589	150-037	Neon, ST2-27S	
B602	150-001	Incandescent, #47	Pilot Light
B603	150-031	Incandescent, #44	Graticule Light
B604	150-031	Incandescent, #44	Graticule Light
B1184	150-030	Neon, NE-2 V	
B1194	150-030	Neon, NE-2 V	

Capacitors

Tolerance $\pm 20\%$ unless otherwise indicated.

Tolerance of all electrolytic capacitors as follows (with exceptions):

3 V — 50 V = -10% , $+250\%$
 51 V — 350 V = -10% , $+100\%$
 351 V — 450 V = -10% , $+50\%$

C1	283-001	0.005 μ f	Cer	500 v	
C2	281-523	100 pf	Cer	350 v	
C4	283-002	0.01 μ f	Cer	500 v	
C5	283-000	0.001 μ f	Cer	500 v	
C6	281-512	27 pf	Cer	500 v	10%
C8	283-002	0.01 μ f	Cer	500 v	
C11	283-001	0.005 μ f	Cer	500 v	
C12	281-523	100 pf	Cer	350 v	
C18	283-067	0.001 μ f	Cer	200 v	10%
C41	281-523	100 pf	Cer	350 v	
C43	281-525	470 pf	Cer	500 v	
C49	283-006	0.02 μ f	Cer	600 v	
C50	283-002	0.01 μ f	Cer	500 v	
C51	283-002	0.01 μ f	Cer	500 v	
C53	283-000	0.001 μ f	Cer	500 v	

Parts List — Type 546

Capacitors (Cont'd)

Ckt. No.	Tektronix Part No.		Description		S/N Range
C56	281-576	11 pf	Cer	500 v	5%
C67	283-026	0.2 μ f	Cer	25 v	
C76	290-187	4.7 μ f	EMT	35 v	
C78	283-003	0.01 μ f	Cer	150 v	
C83	281-524	150 pf	Cer	500 v	
C85	281-519	47 pf	Cer	500 v	10%
C90A	281-007	3-12 pf	Cer	Var	
C90B	281-007	3-12 pf	Cer	Var	
C90C	281-010	4.5-25 pf	Cer	Var	
C90D	281-574	82 pf	Cer	500 v	10%
C90E } C90F } C90G } C90H } C90J }	*295-073	0.001 μ f } 0.01 μ f } 0.1 μ f } 1 μ f } 10 μ f }	Timing Series		
C90K	281-524	150 pf	Cer	500 v	
C92	283-001	0.005 μ f	Cer	500 v	
C94	281-578	18 pf	Cer	500 v	5%
C96	283-006	0.02 μ f	Cer	600 v	
C98	281-557	1.8 pf	Cer	500 v	
C99	281-007	3-12 pf	Cer	Var	
C101	281-523	100 pf	Cer	350 v	
C103	283-000	0.001 μ f	Cer	500 v	
C128	281-550	120 pf	Cer	500 v	10%
C130A	281-550	120 pf	Cer	500 v	10%
C130B	285-543	0.0022 μ f	PTM	400 v	
C130C	285-636	0.022 μ f	PTM	200 v	
C130D	285-633	0.22 μ f	PTM	100 v	10%
C130E	285-576	1 μ f	PTM	100 v	10%
C137	281-523	100 pf	Cer	350 v	
C144	283-002	0.01 μ f	Cer	500 v	
C146	281-512	27pf	Cer	500 v	10%
C166	281-543	270 pf	Cer	500 v	10%
C170	281-605	200 pf	Cer	500 v	
C181	281-544	5.6 pf	Cer	500 v	10%
C184	281-512	27 pf	Cer	500 v	10%
C186	281-012	7-45 pf	Cer	Var	
C188	283-002	0.01 μ f	Cer	500 v	
C192	283-006	0.02 μ f	Cer	600 v	
C197	283-006	0.02 μ f	Cer	600 v	
C199	281-511	22 pf	Cer	500 v	10%
C201	283-001	0.005 μ f	Cer	500 v	
C202	281-523	100 pf	Cer	350 v	
C204	283-002	0.01 μ f	Cer	500 v	
C205	283-000	0.001 μ f	Cer	500 v	
C206	281-512	27 pf	Cer	500 v	10%

Capacitors (Cont'd)

Ckt. No.	Tektronix Part No.		Description		S/N Range
C211	283-001	0.005 μ f	Cer	500 v	
C212	281-523	100 pf	Cer	350 v	
C218	283-000	0.001 μ f	Cer	500 v	
C241	281-523	100 pf	Cer	350 v	
C243	281-525	470 pf	Cer	500 v	
C249	283-006	0.02 μ f	Cer	600 v	
C253	283-000	0.001 μ f	Cer	500 v	
C256	281-576	11 pf	Cer	500 v	5%
C265	283-000	0.001 μ f	Cer	500 v	
C267	283-026	0.2 μ f	Cer	25 v	
C276	290-187	4.7 μ f	EMT	35 v	20%
C278	283-003	0.01 μ f	Cer	150 v	
C283	281-524	150 pf	Cer	500 v	
C290A	281-007	3-12 pf	Cer	Var	
C290B	281-007	3-12 pf	Cer	Var	
C290C	281-010	4.5-25 pf	Cer	Var	
C290D	281-574	82 pf	Cer	500 v	10%
C290E } C290F } C290G } C290H } C290J }	*295-073	0.001 μ f } 0.01 μ f } 0.1 μ f } 1 μ f } 10 μ f }		Timing Series	
C292	283-001	0.005 μ f	Cer	500 v	
C294	281-528	82 pf	Cer	500 v	10%
C296	283-006	0.02 μ f	Cer	600 v	
C299	281-007	3-12 pf	Cer	Var	
C301	281-519	47 pf	Cer	500 v	10%
C303	283-000	0.001 μ f	Cer	500 v	
C311	283-000	0.001 μ f	Cer	500 v	
C314	283-002	0.01 μ f	Cer	500 v	
C328	281-550	120 pf	Cer	500 v	10%
C329	281-519	47 pf	Cer	500 v	10%
C330A	281-550	120 pf	Cer	500 v	10%
C330B	285-543	0.0022 μ f	PTM	400 v	
C330C	285-636	0.022 μ f	PTM	200 v	
C330D	285-633	0.22 μ f	PTM	100 v	10%
C330E	285-576	1 μ f	PTM	100 v	10%
C337	281-523	100 pf	Cer	350 v	
C344	283-002	0.01 μ f	Cer	500 v	
C346	281-512	27 pf	Cer	500 v	10%
C360	281-523	100 pf	Cer	350 v	
C365	281-543	270 pf	Cer	500 v	10%
C369	281-546	330 pf	Cer	500 v	10%
C370	281-605	200 pf	Cer	500 v	
C375	281-544	5.6 pf	Cer	500 v	10%
C382	283-006	0.02 μ f	Cer	600 v	
C392	283-006	0.02 μ f	Cer	600 v	
C397	283-006	0.02 μ f	Cer	600 v	

Parts List — Type 546

Capacitors (Cont'd)

Ckt. No.	Tektronix Part No.		Description		S/N Range
C398	283-002	0.01 μ f	Cer		500 v
C399	283-002	0.01 μ f	Cer		500 v
C406	283-001	0.005 μ f	Cer		500 v
C412	285-572	0.1 μ f	PTM		200 v
C424	283-000	0.001 μ f	Cer		500 v
C426	281-523	100 pf	Cer		350 v
C428	283-001	0.005 μ f	Cer		500 v
C436	283-002	0.01 μ f	Cer		500 v
C438	283-002	0.01 μ f	Cer		500 v
C439	283-001	0.005 μ f	Cer		500 v
C503A	281-558	18 pf	Cer		500 v
C503C	281-012	7-45 pf	Cer	Var	
C503D	281-560	198 pf	Cer		500 v
C516	283-001	0.005 μ f	Cer		500 v
C524	281-010	4.5-25 pf	Cer	Var	
C525	281-557	1.8 pf	Cer		500 v
C538	281-549	68 pf	Cer		500 v
C541	283-002	0.01 μ f	Cer		500 v
C544	281-549	68 pf	Cer		500 v
C550	283-000	0.001 μ f	Cer		500 v
C557D	281-009	3-12 pf	Cer	Var	
C557F	281-013	8-50 pf	Cer	Var	
C557H	281-013	8-50 pf	Cer	Var	
C572	281-022	8-50 pf	Cer	Var	
C574	283-001	0.005 μ f	Cer		500 v
C576	281-053	0.35-1.37 pf	Poly	Var	
C579	283-068	0.01 μ f	Cer		500 v
C582	281-022	8-50 pf	Cer	Var	
C584	283-001	0.005 μ f	Cer		500 v
C586	281-053	0.35-1.37 pf	Poly	Var	
C589	283-068	0.01 μ f	Cer		500 v
C591	281-036	3-12 pf	Cer	Var	
C592	283-002	0.01 μ f	Cer		500 v
C598	285-628	0.033 μ f	PTM		300 v
C599	283-000	0.001 μ f	Cer		500 v
C600	285-519	0.047 μ f	PTM		400 v
C610	285-510	0.01 μ f	PTM		400 v
C617	285-519	0.047 μ f	PTM		400 v
C628	285-510	0.01 μ f	PMT		400 v
C636	281-519	47 pf	Cer		500 v
C640	283-022	0.02 μ f	Cer		1400 v
C642A,B	*290-242	250 μ f x 40 μ f	EMC		350 v/250 v
C650	285-510	0.01 μ f	PTM		400 v
C670	283-022	0.02 μ f	Cer		1400 v
C671	*290-240	300 μ f	EMC		250 v

Capacitors (Cont'd)

Ckt. No.	Tektronix Part No.		Description		S/N Range
C680	285-510	0.01 μ f	PTM	400 v	
C688	285-510	0.01 μ f	PTM	400 v	
C694	281-523	100 pf	Cer	350 v	
C701	*290-241	200 μ f	EMC	400 v	
C709A	*290-238	10 μ f	EMC	450 v	
C709B		10 μ f		350 v	
C709C		20 μ f		250 v	
C710	285-511	0.01 μ f	PTM	600 v	
C730	*290-239	125 μ f	EMC	250 v	
C754	283-002	0.01 μ f	Cer	500 v	
C756	283-002	0.01 μ f	Cer	500 v	
C760	281-549	68 pf	Cer	500 v	10%
C765	281-505	12 pf	Cer	500 v	10%
C767	283-003	0.01 μ f	Cer	150 v	
C768	281-604	2.2 pf	Cer	500 v	± 0.25 pf
C769	283-006	0.02 μ f	Cer	600 v	
C770	283-002	0.01 μ f	Cer	500 v	
C771	*290-229	2 x 40 μ f	EMC	250 v	
C772	283-002	0.01 μ f	Cer	500 v	
C773A	*290-237	40 μ f	EMC	250 v	
C773B		20 μ f		350 v	
C773C		20 μ f		450 v	
C774	283-002	0.01 μ f	Cer	500 v	
C775	283-002	0.01 μ f	Cer	500 v	
C777	283-002	0.01 μ f	Cer	500 v	
C802	*290-243	40 μ f	EMC	400 v	
C803	283-000	0.001 μ f	Cer	500 v	
C806	285-506	0.0047 μ f	PTM	400 v	
C808	285-502	0.001 μ f	PTM	1000 v	
C820	283-082	0.01 μ f	Cer	4000 v	
C821	283-082	0.01 μ f	Cer	4000 v	
C822	281-525	470 pf	Cer	500 v	
C823	283-101	0.0047 μ f	Cer	6000 v	
C828	281-536	0.001 μ f	Cer	500 v	10%
C829	283-082	0.01 μ f	Cer	4000 v	
C830	283-082	0.01 μ f	Cer	4000 v	
C832	283-002	0.01 μ f	Cer	500 v	
C833	281-556	500 pf	Cer	10000 v	
C834	281-556	500 pf	Cer	10000 v	
C835	281-511	22 pf	Cer	500 v	10%
C836	283-096	500 pf	Cer	20000 v	
C841	283-006	0.02 μ f	Cer	600 v	
C842	283-082	0.01 μ f	Cer	4000 v	
C852	283-082	0.01 μ f	Cer	4000 v	
C854	283-082	0.01 μ f	Cer	4000 v	
C858	283-082	0.01 μ f	Cer	4000 v	
C863	283-002	0.01 μ f	Cer	500 v	

Parts List — Type 546

Capacitors (Cont'd)

Ckt. No.	Tektronix Part No.		Description		S/N Range
C932	283-041	0.0033 μ f	Cer	500 v	5%
C934	283-032	470 pf	Cer	500 v	5%
C939	283-057	0.1 μ f	Cer	200 v	
C941	283-006	0.02 μ f	Cer	600 v	
C944	283-057	0.1 μ f	Cer	200 v	
C958	281-525	470 pf	Cer	500 v	
C965	281-523	100 pf	Cer	350 v	
C1000	281-601	7.5 pf	Cer	500 v	± 0.5 pf
C1002	283-001	0.005 μ f	Cer	500 v	
C1014	283-067	0.001 μ f	Cer	200 v	10%
C1016	281-519	47 pf	Cer	500 v	10%
C1024	283-067	0.001 μ f	Cer	200 v	10%
C1026	281-519	47 pf	Cer	500 v	10%
C1027	281-558	18 pf	Cer	500 v	
C1028	283-001	0.005 μ f	Cer	500 v	
C1029	281-006	1.5-7 pf	Cer	Var	
C1031	281-572	6.8 pf	Cer	500 v	10%
C1035	283-067	0.001 μ f	Cer	200 v	10%
C1038	283-067	0.001 μ f	Cer	200 v	10%
C1042	281-572	6.8 pf	Cer	500 v	10%
C1048	283-067	0.001 μ f	Cer	200 v	10%
C1069	283-067	0.001 μ f	Cer	200 v	10%
C1071	283-067	0.001 μ f	Cer	200 v	10%
C1074	281-503	8 pf	Cer	500 v	± 0.5 pf
C1076	281-075	5-25 pf	Cer	Var	
C1077	281-549	68 pf	Cer	500 v	10%
C1087	283-067	0.001 μ f	Cer	200 v	10%
C1103	281-511	22 pf	Cer	500 v	10%
C1104	281-524	150 pf	Cer	500 v	
C1105	281-075	5-25 pf	Cer	Var	
C1106	281-075	5-25 pf	Cer	Var	
C1107	281-600	35 pf	Cer		10%
C1113	283-067	0.001 μ f	Cer	200 v	10%
C1116	283-001	0.005 μ f	Cer	500 v	
C1124	281-524	150 pf	Cer	500 v	
C1126	281-075	5-25 pf	Cer	Var	
C1127	281-558	18 pf	Cer	500 v	
C1132	283-067	0.001 μ f	Cer	200 v	10%
C1142	283-067	0.001 μ f	Cer	200 v	10%
C1152	283-067	0.001 μ f	Cer	200 v	10%
C1153	283-001	0.005 μ f	Cer	500 v	
C1157	283-067	0.001 μ f	Cer	200 v	10%
C1161	283-001	0.005 μ f	Cer	500 v	
C1163	283-006	0.02 μ f	Cer	600 v	
C1181	283-067	0.001 μ f	Cer	200 v	10%
C1191	283-067	0.001 μ f	Cer	200 v	10%

Connector

Ckt. No.	Tektronix Part No.	Description	S/N Range
J11	131-018	16 contact, female. chassis mounted	

Diodes

D45	152-154	Tunnel	TD253	10 MA
D57	*152-075	Germanium	Tek Spec	
D59	*152-075	Germanium	Tek Spec	
D69	152-141	Silicon	1N3605	
D71	152-141	Silicon	1N3605	
D76	152-119	Zener	1N969A	.4 w, 22 v, 10%
D79	152-141	Silicon	1N3605	
D83	*152-075	Germanium	Tek Spec	
D85	152-156	Tunnel	TD203A	4.7 MA
D86	*152-161	Tek	GaAs	
D97	152-118	Zener	1N3033	1 w, 36 v, 20%
D98	*152-061	Silicon	Tek Spec	
D100	*152-061	Silicon	Tek Spec	
D129	*152-061	Silicon	Tek Spec	
D132	*152-061	Silicon	Tek Spec	
D147	152-141	Silicon	1N3605	
D163	152-141	Silicon	1N3605	
D164	*152-075	Germanium	Tek Spec	
D172	*152-061	Silicon	Tek Spec	
D245	152-154	Tunnel	TD253	10 MA
D257	*152-075	Germanium	Tek Spec	
D259	*152-075	Germanium	Tek Spec	
D265	152-008	Germanium		
D269	152-141	Silicon	1N3605	
D271	152-141	Silicon	1N3605	
D277	152-119	Zener	1N969A	.4 w, 22 v, 10%
D279	152-141	Silicon	1N3605	
D283	*152-075	Germanium	Tek Spec	
D285	152-156	Tunnel	TD203A	4.7 MA
D286	*152-161	Tek	GaAs	
D297	152-118	Zener	1N3033	1 w, 36 v, 20%
D298	*152-061	Silicon	Tek Spec	
D300	*152-061	Silicon	Tek Spec	
D329	*152-061	Silicon	Tek Spec	
D332	*152-061	Silicon	Tek Spec	
D347	152-141	Silicon	1N3605	
D362	152-141	Silicon	1N3605	
D363	152-141	Silicon	1N3605	
D367	152-141	Silicon	1N3605	
D372	*152-061	Silicon	Tek Spec	

Parts List — Type 546

Diodes (Cont'd)

Ckt. No.	Tektronix Part No.	Description	S/N Range
D405	152-155	Tunnel TD202	2.2 MA
D433	152-141	Silicon 1N3605	
D541	152-067	Zener 1M25Z10	1 w, 25 w, 10%
D542	*152-075	Germanium Tek Spec	
D561	*152-075	Germanium Tek Spec	
D582	*152-061	Silicon Tek Spec	
D642A,B,C,D,	152-066	Silicon 1N3194	
D672A,B,C,D	*152-047	Replaceable by 1N2862	
D693	152-157	Zener .4M140Z10	.4 w, 140 v, 10%
D702A,B	152-066	Silicon 1N3194	
D732A,B	152-066	Silicon 1N3194	
D759	152-141	Silicon 1N3605	
D769	*152-061	Silicon Tek Spec	
D942	*152-061	Silicon Tek Spec	
D948	152-004	Zener 1N707 or 1N763	1/4 w, 6.2 v - 8 v
D1014	152-141	Silicon 1N3605	
D1018	152-120	Zener 1N3020B	1 w, 10 v, 5%
D1024	152-141	Silicon 1N3605	

Fuses

F601	159-011	6.25 Amp 3AG Slo-Blo, 115 v, 50-60 and 400 cps
	159-005	3 Amp 3AG Slo-Blo, 230 v, 50-60 and 400 cps

Inductors

LR21	*108-230	3.25 μ h on 150 Ω 1/2 w 5% resistor
LR23	*108-230	3.25 μ h on 150 Ω 1/2 w 5% resistor
L44	276-507	Core, Ferramic Suppressor
L52	*108-147	2.2 μ h
L56	*108-215	1.1 μ h
LR221	*108-230	3.25 μ f on 150 Ω 1/2 w 5% resistor
LR223	*108-230	3.25 μ f on 150 Ω 1/2 w 5% resistor
L244	276-507	Core, Ferramic Suppressor
L252	*108-147	2.2 μ h
L256	*108-215	1.1 μ h
L404	*120-309	Toroid, 6T Single
L553	*119-030	Delay Line Assembly
L760	108-240	820 μ h
L778	*108-265	Beam Rotator
L1013	*108-260	0.1 μ h
L1018	*120-266	Toroid, 10T Single
L1023	*108-260	0.1 μ h
L1030	*108-264	0.2 μ h
L1040	*108-264	0.2 μ h
L1051	*108-260	0.1 μ h
LR1052	*108-288	1.2 μ h on 6.2 Ω 1/2 w 5% resistor
L1061	*108-260	0.1 μ h

Inductors (continued)

Ckt. No.	Tektronix Part No.	Description	S/N Range
LR1062	*108-288	1.2 μ h on 6.2 Ω 1/2 w 5% resistor	
L1072	*108-260	0.1 μ h	
L1082	*108-260	0.1 μ h	
LR1115	*131-335	0.5 μ h on 330 Ω 1/4 w resistor	
LR1135	*131-336	0.5 μ h on 330 Ω 1/4 w resistor	
L1144	*108-095	1.4 μ h	
L1154	*108-095	1.4 μ h	
L1157	*114-080	6.8 μ h - 14.6 μ h	Var
L1160	276-528	Core, Ferramic Suppressor	
L1170	276-528	Core, Ferramic Suppressor	

Relays

K600	148-021	Tube Relay
K601	*148-019	Tek Spec

Transistors

Q34	151-089	2N962
Q44	151-089	2N962
Q65	*151-108	Replaceable by 2N2501
Q75	*151-108	Replaceable by 2N2501
Q84	*151-108	Replaceable by 2N2501
Q89	*151-096	Selected from 2N1893
Q103	151-089	2N962
Q173	151-063	2N2207
Q234	151-089	2N962
Q244	151-089	2N962
Q265	*151-108	Replaceable by 2N2501
Q275	*151-108	Replaceable by 2N2501
Q284	*151-108	Replaceable by 2N2501
Q289	*151-096	Selected from 2N1893
Q303	151-089	2N962
Q373	151-063	2N2207
Q424	151-063	2N2207
Q433	*151-103	Replaceable by 2N2219
Q534	*151-121	Selected from TA1938
Q543	*151-096	Selected from 2N1893
Q554	151-063	2N2207
Q564	151-063	2N2207
Q1014 } Q1024 }	*153-525	Matched pair

Parts List — Type 546

Transistors (Cont'd)

Ckt. No.	Tektronix Part No.	Description	S/N Range
Q1034 } Q1044 } Q1074 } Q1084 }	*153-527	Matched pair	
	*153-525	Matched pair	
Q1104† Q1114†† Q1124† Q1134††	*153-526 *153-524 *153-526 *153-524		
Q1144 } Q1154 } Q1163 Q1173	*153-527 *151-127 *151-127	Matched pair Selected from 2N2369 Selected from 2N2369	

Resistors

Resistors are fixed, composition, $\pm 10\%$ unless otherwise indicated.

R5	302-104	100 k	$\frac{1}{2}$ w			
R6	321-385	100 k	$\frac{1}{8}$ w		Prec	1%
R7	323-406	165 k	$\frac{1}{2}$ w		Prec	1%
R8	316-101	100 Ω	$\frac{1}{4}$ w			
R9	311-018	20 k		Var		B INT TRIG DC LEVEL
R13	323-481	1 meg	$\frac{1}{2}$ w		Prec	1%
R14	302-155	1.5 meg	$\frac{1}{2}$ w			
R15†††	311-426	300 k		Var		TRIGGERING LEVEL
R16	302-394	390 k	$\frac{1}{2}$ w			
R17	302-335	3.3 meg	$\frac{1}{2}$ w			
R18	302-104	100 k	$\frac{1}{2}$ w			
R19	316-105	1 meg	$\frac{1}{4}$ w			
R20	316-101	100 Ω	$\frac{1}{4}$ w			
R21	316-221	220 Ω	$\frac{1}{4}$ w			
R22	316-101	100 Ω	$\frac{1}{4}$ w			
R23	316-221	220 Ω	$\frac{1}{4}$ w			
R24	308-108	15 k	5 w		WW	5%
R25	311-158	200 Ω		Var		B TRIGGER LEVEL CENTERING
R27	308-267	7.5 k	5 w		WW	5%
R28	302-102	1 k	$\frac{1}{2}$ w			
R36	324-335	30.1 k	1 w		Prec	1%
R41	316-221	220 Ω	$\frac{1}{4}$ w			
R43	316-100	10 Ω	$\frac{1}{4}$ w			
R44	322-001	10 Ω	$\frac{1}{4}$ w		Prec	1%
R45	311-324	50 Ω	$\frac{1}{2}$ w	Var	WW	B TRIGGER SENS

†Q1104 and Q1124 furnished as a matched pair.

††Q1114 and Q1134 furnished as a matched pair.

†††Furnished as a unit with SW15.

Resistors (Cont'd)

Ckt. No.	Tektronix Part No.		Description		S/N Range
R47	324-306	15 k	1 w	Prec	1%
R48	324-306	15 k	1 w	Prec	1%
R49	302-101	100 Ω	$\frac{1}{2}$ w		
R50	302-101	100 Ω	$\frac{1}{2}$ w		
R51	302-101	100 Ω	$\frac{1}{2}$ w		
R53	323-370	69.8 k	$\frac{1}{2}$ w	Prec	1%
R54	323-140	280 Ω	$\frac{1}{2}$ w	Prec	1%
R56	316-102	1 k	$\frac{1}{4}$ w		
R57	302-224	220 k	$\frac{1}{2}$ w		
R63	316-470	47 Ω	$\frac{1}{4}$ w		
R65	301-303	30 k	$\frac{1}{2}$ w		5%
R67	301-912	9.1 k	$\frac{1}{2}$ w		5%
R69	302-103	10 k	$\frac{1}{2}$ w		
R71	303-513	51 k	1 w		5%
R75	301-513	51 k	$\frac{1}{2}$ w		5%
R76	302-471	470 Ω	$\frac{1}{2}$ w		
R78	301-752	7.5 k	$\frac{1}{2}$ w		5%
R79	302-152	1.5 k	$\frac{1}{2}$ w		
R81	316-101	100 Ω	$\frac{1}{4}$ w		
R82	323-333	28.7 k	$\frac{1}{2}$ w	Prec	1%
R83	316-394	390 k	$\frac{1}{4}$ w		
R84	305-153	15 k	2 w		5%
R85	315-102	1 k	$\frac{1}{4}$ w		5%
R86	303-513	51 k	1 w		5%
R87	315-273	27 k	$\frac{1}{4}$ w		5%
R88	302-823	82 k	$\frac{1}{2}$ w		
R89	302-105	1 meg	$\frac{1}{2}$ w		
R90A	*312-640	140 k	$\frac{1}{2}$ w		1%
R90B		280 k	$\frac{1}{2}$ w		1%
R90C		700 k	$\frac{1}{2}$ w		1%
R90D	*312-641	1.4 meg	$\frac{1}{2}$ w		1%
R90E		2.8 meg	$\frac{1}{2}$ w		1%
R90F		7 meg	$\frac{1}{2}$ w		1%
R90K	302-271	270 Ω	$\frac{1}{2}$ w		
R90W	302-105	1 meg	$\frac{1}{2}$ w		
R90X	302-104	100 k	$\frac{1}{2}$ w		
R90Y	301-392	3.9 k	$\frac{1}{2}$ w		5%
R90Z†	311-391	150 k		Var	VARIABLE
R92	316-101	100 Ω	$\frac{1}{4}$ w		
R93	304-473	47 k	1 w		
R94	304-473	47 k	1 w		
R95	316-101	100 Ω	$\frac{1}{4}$ w		
R96	316-101	100 Ω	$\frac{1}{4}$ w		
R98	315-303	30 k	$\frac{1}{4}$ w		5%
R99	323-356	49.9 k	$\frac{1}{2}$ w	Prec	1%

†Furnished as a unit with SW90Z.

Parts List — Type 546

Resistors (Cont'd)

Ckt. No.	Tektronix Part No.		Description		S/N Range
R100	316-272	2.7 k	1/4 w		
R101	316-122	1.2 k	1/4 w		
R102	316-153	15 k	1/4 w		
R103	306-273	27 k	2 w		
R105	302-152	1.5 k	1/2 w		
R121	306-683	68 k	2 w		
R124	303-163	16 k	1 w		5%
R125	311-011	5 k		Var	B SWEEP LENGTH
R126	305-393	39 k	2 w		5%
R128	302-102	1 k	1/2 w		5%
R129	302-562	5.6 k	1/2 w		
R130A	302-155	1.5 meg	1/2 w		
R130C	301-156	15 meg	1/2 w		5%
R137	323-481	1 meg	1/2 w	Prec	1%
R138	309-439	5.9 meg	1/2 w	Prec	1%
R139	316-101	100 Ω	1/4 w		
R141	301-334	330 k	1/2 w		5%
R142	301-274	270 k	1/2 w		5%
R143	301-683	68 k	1/2 w		5%
R144	302-101	100 Ω	1/2 w		
R145	323-302	13.7 k	1/2 w	Prec	1%
R146	323-385	100 k	1/2 w	Prec	1%
R147	323-402	150 k	1/2 w	Prec	1%
R148	316-101	100 Ω	1/4 w		
R149	302-122	1.2 k	1/2 w		
R162	323-243	3.32 k	1/2 w	Prec	1%
R163	308-268	22 k	5 w	WW	1%
R164	324-339	33.2 k	1 w	Prec	1%
R165	301-183	18 k	1/2 w		5%
R166	301-134	130 k	1/2 w		5%
R170	315-472	4.7 k	1/4 w		5%
R171	302-472	4.7 k	1/2 w		
R172	302-274	270 k	1/2 w		
R173	316-101	100 Ω	1/4 w		
R176	316-270	27 Ω	1/4 w		
R180	323-353	46.4 k	1/2 w	Prec	1%
R181	323-330	26.7 k	1/2 w	Prec	1%
R182	323-356	49.9 k	1/2 w	Prec	1%
R184	323-469	750 k	1/2 w	Prec	1%
R186	309-448	9.31 meg	1/2 w	Prec	1%
R187	309-447	6.19 meg	1/2 w	Prec	1%
R188	316-100	10 Ω	1/4 w		
R189	311-419	500 k		Var	BRIGHTNESS
R190	316-101	100 Ω	1/4 w		
R191	316-470	47 Ω	1/4 w		

Resistors (Cont'd)

Ckt. No.	Tektronix Part No.		Description		S/N Range
R192	316-101	100 Ω	$\frac{1}{4}$ w		
R193	302-104	100 k	$\frac{1}{2}$ w		
R194	316-820	82 Ω	$\frac{1}{4}$ w		
R195	323-373	75 k	$\frac{1}{2}$ w	Prec	1%
R196	316-470	47 Ω	$\frac{1}{4}$ w		
R197	316-101	100 Ω	$\frac{1}{4}$ w		
R198	302-472	4.7 k	$\frac{1}{2}$ w		
R199	302-103	10 k	$\frac{1}{2}$ w		
R205	302-104	100 k	$\frac{1}{2}$ w		
R206	321-385	100 k	$\frac{1}{8}$ w	Prec	1%
R207	323-406	165 k	$\frac{1}{2}$ w	Prec	1%
R209	311-018	20 k		Var	A INT TRIG DC LEVEL
R210	316-103	10 k	$\frac{1}{4}$ w		
R211	316-222	2.2 k	$\frac{1}{4}$ w		
R213	323-481	1 meg	$\frac{1}{4}$ w	Prec	1%
R214	302-155	1.5 meg	$\frac{1}{2}$ w		
R215†	311-426	300 k		Var	TRIGGERING LEVEL
R216	302-394	390 k	$\frac{1}{2}$ w		
R217	302-335	3.3 meg	$\frac{1}{2}$ w		
R218	302-104	100 k	$\frac{1}{2}$ w		
R219	316-105	1 meg	$\frac{1}{4}$ w		
R220	316-470	47 Ω	$\frac{1}{4}$ w		
R221	316-221	220 Ω	$\frac{1}{4}$ w		
R222	316-470	47 Ω	$\frac{1}{4}$ w		
R223	316-221	220 Ω	$\frac{1}{4}$ w		
R224	308-108	15 k	5 w		
R225	311-004	200 Ω		Var	WW 5% A TRIGGER LEVEL CENTERING
R227	308-267	7.5 k	5 w		WW 5%
R228	302-102	1 k	$\frac{1}{2}$ w		
R236	324-335	30.1 k	1 w	Prec	1%
R241	316-221	220 Ω	$\frac{1}{4}$ w		
R243	316-100	10 Ω	$\frac{1}{4}$ w		
R244	323-001	10 Ω	$\frac{1}{2}$ w	Prec	1%
R245	311-308	50 Ω	2 w	Var	A TRIGGER SENS
R247	324-306	15 k	1 w	Prec	1%
R248	324-306	15 k	1 w	Prec	1%
R249	302-101	100 Ω	$\frac{1}{2}$ w		
R253	323-370	69.8 k	$\frac{1}{2}$ w	Prec	1%
R254	323-140	280 Ω	$\frac{1}{2}$ w	Prec	1%
R255	301-203	20 k	$\frac{1}{2}$ w		5%
R256	301-134	130 k	$\frac{1}{2}$ w		5%
R258	302-473	47 k	$\frac{1}{2}$ w		
R263	316-470	47 Ω	$\frac{1}{4}$ w		
R265	301-303	30 k	$\frac{1}{2}$ w		5%
R267	301-912	9.1 k	$\frac{1}{2}$ w		5%

†Furnished as a unit with SW215.

Parts List — Type 546

Resistors (Cont'd)

Ckt. No.	Tektronix Part No.		Description			S/N Range
R269	302-103	10 k	1/2 w			
R271	303-513	51 k	1 w			5%
R275	301-513	51 k	1/2 w			5%
R276	302-471	470 Ω	1/2 w			
R278	301-752	7.5 k	1/2 w			5%
R279	302-152	1.5 k	1/2 w			
R281	316-101	100 Ω	1/4 w			
R282	323-333	28.7 k	1/2 w		Prec	1%
R283	316-394	390 k	1/4 w			
R284	305-153	15 k	2 w			5%
R285	301-102	1 k	1/2 w			5%
R286	303-513	51 k	1 w			5%
R287	301-273	27 k	1/2 w			5%
R288	302-823	82 k	1/2 w			
R289	302-105	1 meg	1/2 w			
R290A	*312-640	140 k	1/2 w			1%
R290B		280 k	1/2 w			1%
R290C		700 k	1/2 w			1%
R290D	*312-641	1.4 meg	1/2 w			1%
R290E		2.8 meg	1/2 w			1%
R290F		7 meg	1/2 w			1%
R290W		302-105	1 meg	1/2 w		
R290X	302-104	100 k	1/2 w			
R290Y	311-388	7.5 k		Var	WW	A SWEEP CAL
R290Z†	311-391	150 k		Var		VARIABLE
R292	316-101	100 Ω	1/4 w			
R293	304-473	47 k	1 w			
R294	304-473	47 k	1 w			
R295	316-101	100 Ω	1/4 w			
R296	316-101	100 Ω	1/4 w			
R299	323-356	49.9 k	1/2 w		Prec	1%
R301	316-471	470 Ω	1/4 w			
R302	316-153	15 k	1/4 w			
R303	306-273	27 k	2 w			
R305	316-152	1.5 k	1/4 w			
R310	301-272	2.7 k	1/2 w			5%
R311	302-104	100 k	1/2 w			
R312	316-101	100 Ω	1/4 w			
R314	316-101	100 Ω	1/4 w			
R316	302-104	100 k	1/2 w			
R321	306-683	68 k	2 w			

†Furnished as a unit with SW290Z.

Resistors (Cont'd)

Ckt. No.	Tektronix Part No.		Description		S/N Range
R324	303-163	16 k	1 w	Var	5% A SWEEP LENGTH
R325	311-011	5 k			
R326	305-393	39 k	2 w		
R328	302-102	1 k	1/2 w		
R329	302-562	5.6 k	1/2 w		
R330A	301-155	1.5 meg	1/2 w		5%
R330B	301-565	5.6 meg	1/2 w		5%
R330C	301-156	15 meg	1/2 w		5%
R330D	301-226	22 meg	1/2 w		5%
R331	301-683	68 k	1/2 w		5%
R332	301-682	6.8 k	1/2 w		5%
R334	323-373	75 k	1/2 w	Prec	1%
R335	323-273	6.81 k	1/2 w	Prec	1%
R337	323-481	1 meg	1/2 w	Prec	1%
R338	309-439	5.9 meg	1/2 w	Prec	1%
R339	316-101	100 Ω	1/4 w		
R341	301-334	330 k	1/2 w		5%
R342	301-274	270 k	1/2 w		5%
R343	301-683	68 k	1/2 w		5%
R344	302-101	100 Ω	1/2 w		
R345	323-302	13.7 k	1/2 w	Prec	1%
R346	323-385	100 k	1/2 w	Prec	1%
R347	323-402	150 k	1/2 w	Prec	1%
R348	316-101	100 Ω	1/4 w		
R349	302-122	1.2 k	1/2 w		
R359	316-273	27 k	1/4 w		
R360	316-222	2.2 k	1/4 w		
R361	323-243	3.32 k	1/2 w	Prec	1%
R362	308-302	20 k	5 w	W/W	1%
R363	324-339	33.2 k	1 w	Prec	1%
R364	301-303	30 k	1/2 w		5%
R365	301-274	270 k	1/2 w		5%
R366	316-102	1 k	1/4 w		
R367	316-182	1.8 k	1/4 w		
R368	316-336	33 meg	1/4 w		
R369	316-182	1.8 k	1/4 w		
R370	301-472	4.7 k	1/2 w		5%
R371	302-472	4.7 k	1/2 w		
R372	302-274	270 k	1/2 w		
R373	316-470	47 Ω	1/4 w		
R374	323-353	46.4 k	1/2 w	Prec	1%
R375	323-330	26.7 k	1/2 w	Prec	1%
R376	323-356	49.9 k	1/2 w	Prec	1%
R381	316-470	47 Ω	1/4 w		
R382	316-101	100 Ω	1/4 w		
R383	302-104	100 k	1/2 w		

Parts List — Type 546

Resistors (Cont'd)

Ckt. No.	Tektronix Part No.		Description			S/N Range
R384	316-820	82 Ω	$\frac{1}{4}$ w			
R390	323-373	75 k	$\frac{1}{2}$ w		Prec	1%
R391	316-470	47 Ω	$\frac{1}{4}$ w			
R392	316-101	100 Ω	$\frac{1}{4}$ w			
R393	302-472	4.7 k	$\frac{1}{2}$ w			
R394	316-101	100 Ω	$\frac{1}{4}$ w			
R397	307-106	4.7 Ω	$\frac{1}{4}$ w			5%
R398	316-101	100 Ω	$\frac{1}{4}$ w			
R399	316-101	100 Ω	$\frac{1}{4}$ w			
R401	316-101	100 Ω	$\frac{1}{4}$ w			
R404	302-331	330 Ω	$\frac{1}{2}$ w			
R406	301-563	56 k	$\frac{1}{2}$ w			5%
R407	301-913	91 k	$\frac{1}{2}$ w			5%
R408	316-101	100 Ω	$\frac{1}{4}$ w			
R409	303-183	18 k	1 w			5%
R412	316-101	100 Ω	$\frac{1}{4}$ w			
R413	316-473	47 k	$\frac{1}{4}$ w			
R414	324-339	33.2 k	1 w			
R415	311-015	10 k		Var	Prec WW	1% DELAY STOP
R416	311-022	30 k		Var		DELAY TIME MULTIPLIER 1-10
R417	302-331	330 k	$\frac{1}{2}$ w			
R418	311-141	2 k		Var	WW	DELAY START
R419	308-268	22 k	5 w		WW	1%
R421	316-101	100 Ω	$\frac{1}{4}$ w			
R424	302-564	560 k	$\frac{1}{2}$ w			
R425	301-104	100 k	$\frac{1}{2}$ w			5%
R426	301-223	22 k	$\frac{1}{2}$ w			5%
R428	302-223	22 k	$\frac{1}{2}$ w			
R429	302-682	6.8 k	$\frac{1}{2}$ w			
R430	302-333	33 k	$\frac{1}{2}$ w			
R431	302-151	150 Ω	$\frac{1}{2}$ w			
R432	316-470	47 Ω	$\frac{1}{4}$ w			
R433	302-102	1 k	$\frac{1}{2}$ w			
R435	302-562	5.6 k	$\frac{1}{2}$ w			
R438	302-101	100 Ω	$\frac{1}{2}$ w			
R439	302-102	1 k	$\frac{1}{2}$ w			
R501	302-470	47 Ω	$\frac{1}{2}$ w			
R503C	323-611	900 k	$\frac{1}{2}$ w		Prec	1%
R503D	323-610	111 k	$\frac{1}{2}$ w		Prec	1%
R507	323-481	1 meg	$\frac{1}{2}$ w		Prec	1%
R508	316-102	1 k	$\frac{1}{4}$ w			
R509	306-333	33 k	2 w			
R510	301-201	200 Ω	$\frac{1}{2}$ w			5%
R511	311-418	10 k		Var		VAR 10-1
R512	306-333	33 k	2 w			

Resistors (Cont'd)

Ckt. No.	Tektronix Part No.		Description		S/N Range
R514	316-101	100 Ω	$\frac{1}{4}$ w		
R516	302-332	3.3 k	$\frac{1}{2}$ w		
R517	302-224	220 k	$\frac{1}{2}$ w		
R519	311-026	100 k		Var	EXT HORIZ DC BAL
R522	305-183	18 k	2 w		5%
R523	301-204	200 k	$\frac{1}{2}$ w		5%
R524	323-356	49.9 k	$\frac{1}{2}$ w	Prec	1%
R525	301-565	5.6 meg	$\frac{1}{2}$ w		5%
R526	302-101	100 Ω	$\frac{1}{2}$ w		
R530A	311-431	50 k		Var	HORIZ POSITION VERNIER
R530B		50 k			
R531	323-369	68.1 k	$\frac{1}{2}$ w	Prec	1%
R532	301-394	390 k	$\frac{1}{2}$ w		5%
R533	323-452	499 k	$\frac{1}{2}$ w	Prec	1%
R534	304-123	12 k	1 w		
R535	316-390	39 Ω	$\frac{1}{4}$ w		
R538	302-123	12 k	$\frac{1}{2}$ w		
R539	303-753	75 k	1 w		5%
R540	304-822	8.2 k	1 w		
R542	301-303	30 k	$\frac{1}{2}$ w		5%
R543	306-393	39 k	2 w		
R544	311-172	2.5 k		Var	X10 CAL
R545	323-284	8.87 k	$\frac{1}{2}$ w	Prec	1%
R547	302-104	100 k	$\frac{1}{2}$ w		
R550	302-823	82 k	$\frac{1}{2}$ w		
R553	323-295	11.5 k	$\frac{1}{2}$ w	Prec	1%
R554	308-211	12 k	5 w	WW	5%
R556	323-252	4.12 k	$\frac{1}{2}$ w	Prec	1%
R557C	323-662	4.28 k	$\frac{1}{2}$ w	Prec	1%
R557E	323-196	1.07 k	$\frac{1}{2}$ w	Prec	1%
R557F	301-182	1.8 k	$\frac{1}{2}$ w		5%
R557G	323-162	475 Ω	$\frac{1}{2}$ w	Prec	1%
R557H	301-122	1.2 k	$\frac{1}{2}$ w		5%
R558	302-104	100 k	$\frac{1}{2}$ w		
R561	302-104	100 k	$\frac{1}{2}$ w		
R563	323-281	8.25 k	$\frac{1}{2}$ w	Prec	1%
R564	308-211	12 k	5 w	WW	5%
R566	311-066	500 Ω	.2 w	Var	X1 CAL
R568	302-473	47 k	$\frac{1}{2}$ w		
R569	311-026	100 k		Var	SWP/MAG REGIS
R570	316-470	47 Ω	$\frac{1}{4}$ w		
R571	308-266	5 k	5 w	WW	5%
R572	*310-600	18 k/4.5 k	7 w	WW	
R573	316-470	47 Ω	$\frac{1}{4}$ w		
R574	316-470	47 Ω	$\frac{1}{4}$ w		
R576	*310-601	30 k	8 w	WW	1%

Parts List — Type 546

Resistors (Cont'd)

Ckt. No.	Tektronix Part No.		Description		S/N Range
R577	302-154	150 k	1/2 w		
R578	316-103	10 k	1/4 w		
R579	302-394	390 k	1/2 w		
R580	316-470	47 Ω	1/4 w		
R581	302-155	1.5 meg	1/2 w		
R582	*310-611	18 k/3.7 k/800 Ω	6 w		WW
R583	316-470	47 Ω	1/4 w		
R584	316-470	47 Ω	1/4 w		
R585	306-224	220 k	2 w		
R586	*310-601	30 k	8 w		WW 1%
R587	302-154	150 k	1/2 w		
R588	316-103	10 k	1/4 w		
R589	302-394	390 k	1/2 w		
R591	302-155	1.5 meg	1/2 w		
R592	302-102	1 k	1/2 w		
R594	302-104	100 k	1/2 w		
R595	302-563	56 k	1/2 w		
R597	316-470	47 Ω	1/4 w		
R598	304-103	10 k	1 w		
R599	302-473	47 k	1/2 w		
R601	308-229	4 k	5 w		WW 5%
R603	308-269	22 Ω	3 w		WW 5%
R605	311-377	25 Ω		Var	SCALE ILLUM
R608	302-333	33 k	1/2 w		
R610	302-104	100 k	1/2 w		
R615	324-369	68.1 k	1 w		Prec 1%
R616	311-015	10 k		Var	WW —150 VOLTS
R617	324-356	49.9 k	1 w		Prec 1%
R618	302-104	100 k	1/2 w		
R621	302-102	1 k	1/2 w		
R623	302-474	470 k	1/2 w		
R625	302-104	100 k	1/2 w		
R628	302-275	2.7 meg	1/2 w		
R629	302-275	2.7 meg	1/2 w		
R631	302-102	1 k	1/2 w		
R632	316-470	47 Ω	1/4 w		
R634	302-105	1 meg	1/2 w		
R635	304-153	15 k	1 w		
R636	304-153	15 k	1 w		
R637	302-684	680 k	1/2 w		
R638	302-273	27 k	1/2 w		
R639	302-683	68 k	1/2 w		
R640	306-100	10 Ω	2 w		
R641	306-100	10 Ω	2 w		
R644	302-102	1 k	1/2 w		

Resistors (Cont'd)

Ckt. No.	Tektronix Part No.		Description		S/N Range
R645	316-470	47 Ω	$\frac{1}{4}$ w		
R646	308-040	1.5 k	25 w	WW	
R647	308-282	1.35 k	25 w	WW	5%
R650	324-443	402 k	1 w	Prec	1%
R651	324-458	576 k	1 w	Prec	1%
R663	302-105	1 meg	$\frac{1}{2}$ w		
R664	304-333	33 k	1 w		
R667	302-334	330 k	$\frac{1}{2}$ w		
R668	302-563	56 k	$\frac{1}{2}$ w		
R669	302-393	39 k	$\frac{1}{2}$ w		
R670A	306-100	10 Ω	2 w		
R670B	306-100	10 Ω	2 w		
R671	308-155	800 Ω	25 w	WW	5%
R673	308-147	750 Ω	25 w	WW	5%
R674	302-102	1 k	$\frac{1}{2}$ w		
R675	303-470	47 Ω	1 w		5%
R676	303-470	47 Ω	1 w		5%
R677	308-207	1.6 k	25 w	WW	5%
R680	324-443	402 k	1 w	Prec	1%
R681	324-601	264 k	1 w	Prec	1%
R682	302-124	120 k	$\frac{1}{2}$ w		
R683	302-102	1 k	$\frac{1}{2}$ w		
R685	304-823	82 k	1 w		
R686	302-184	180 k	$\frac{1}{2}$ w		
R688	302-155	1.5 meg	$\frac{1}{2}$ w		
R689	302-225	2.2 meg	$\frac{1}{2}$ w		
R693	302-155	1.5 meg	$\frac{1}{2}$ w		
R694	302-473	47 k	$\frac{1}{2}$ w		
R697	302-824	820 k	$\frac{1}{2}$ w		
R698	302-274	270 k	$\frac{1}{2}$ w		
R699	302-473	47 k	$\frac{1}{2}$ w		
R700	306-100	10 Ω	2 w		
R701	306-100	10 Ω	2 w		
R703	303-470	47 Ω	1 w		5%
R704	302-102	1 k	$\frac{1}{2}$ w		
R705	303-470	47 Ω	1 w		5%
R706	308-282	1.35 k	25 w	WW	5%
R707	308-282	1.35 k	25 w	WW	5%
R710	324-467	715 k	1 w	Prec	1%
R711	324-604	303 k	1 w	Prec	1%
R712	302-154	150 k	$\frac{1}{2}$ w		
R723	302-105	1 meg	$\frac{1}{2}$ w		
R727	302-105	1 meg	$\frac{1}{2}$ w		
R728	302-684	680 k	$\frac{1}{2}$ w		
R729	302-224	220 k	$\frac{1}{2}$ w		
R730	302-100	10 Ω	$\frac{1}{2}$ w		

Parts List — Type 546

Resistors (Cont'd)

Ckt. No.	Tektronix Part No.		Description			S/N Range
R731	306-823	82 k	2 w			
R734	316-470	47 Ω	1/4 w			
R737	308-192	5 k	20 w		WW	5%
R741	302-104	100 k	1/2 w			
R743	307-103	2.7 Ω	1/4 w			5%
R744	307-103	2.7 Ω	1/4 w			5%
R757	302-154	150 k	1/2 w			
R758	315-823	82 k	1/4 w			5%
R759	315-203	20 k	1/4 w			5%
R760	316-470	47 Ω	1/4 w			
R761	315-472	4.7 k	1/4 w			5%
R762	301-683	68 k	1/2 w			5%
R763	302-185	1.8 meg	1/2 w			
R764	302-105	1 meg	1/2 w			
R765	302-474	470 k	1/2 w			
R766	316-470	47 Ω	1/4 w			
R767	304-122	1.2 k	1 w			
R768	308-286	8.2 k	3 w		WW	5%
R769	316-101	100 Ω	1/4 w			
R771	323-097	100 Ω	1/2 w		Prec	1%
R773	323-097	100 Ω	1/2 w		Prec	1%
R774	324-097	100 Ω	1 w		Prec	1%
R775	323-097	100 Ω	1/2 w		Prec	1%
R777	307-103	2.7 Ω	1/4 w			5%
R778†	311-407	2 x 10 Ω		Var	WW	TRACE ROTATION
R802	306-271	270 Ω	2 w			
R803	306-563	56 k	2 w			
R806	302-104	100 k	1/2 w			
R807	301-432	4.3 k	1/2 w			5%
R814	302-474	470 k	1/2 w			
R820	302-333	33 k	1/2 w			
R821	301-225	2.2 meg	1/2 w			5%
R822	302-333	33 k	1/2 w			
R824	305-755	7.5 meg	2 w			5%
R825	305-755	7.5 meg	2 w			5%
R826	311-450	1 meg		Var		INTENSITY
R827	302-333	33 k	1/2 w			
R828	302-223	22 k	1/2 w			

†Furnished as a unit with R864.

Resistors (Cont'd)

Ckt. No.	Tektronix Part No.		Description			S/N Range
R830	302-335	3.3 meg	1/2 w			
R831	306-183	18 k	2 w			
R832	302-101	100 Ω	1/2 w			
R836	316-105	1 meg	1/4 w			
R840	311-034	500 k		Var		HIGH VOLTAGE
R841	303-225	2.2 meg	1 w			5%
R842	303-335	3.3 meg	1 w			5%
R843	303-275	2.7 meg	1 w			5%
R845	303-335	3.3 meg	1 w			5%
R846	311-313	5 meg		Var		FOCUS
R847	302-474	470 k	1/2 w			
R853	302-103	10 k	1/2 w			
R857	302-273	27 k	1/2 w			
R858	302-105	1 meg	1/2 w			
R859	302-471	470 Ω	1/2 w			
R861	311-026	100 k		Var		GEOMETRY
R862	301-823	82 k	1/2 w			5%
R863	301-473	47 k	1/2 w			5%
R864†	311-407	50 k		Var	WW	ASTIGMATISM
R931	302-154	150 k	1/2 w			
R932	301-394	390 k	1/2 w			5%
R934	301-475	4.7 meg	1/2 w			5%
R935	302-103	10 k	1/2 w			
R936	302-102	1 k	1/2 w			
R938	302-102	1 k	1/2 w			
R939	302-221	220 Ω	1/2 w			
R941	302-221	220 Ω	1/2 w			
R943	311-141	2 k		Var	WW	CAL AMPL
R944	302-100	10 Ω	1/2 w		WW	1%
R945	308-268	22 k	5 w			
R949	302-274	270 k	1/2 w			
R950	323-289	10 k	1/2 w		Prec	1%
R951	323-635	6.667 k	1/2 w		Prec	1%
R952	323-634	1.789 k	1/2 w		Prec	1%
R953	323-633	801 Ω	1/2 w		Prec	1%
R954	323-632	452 Ω	1/2 w		Prec	1%
R955	323-631	146.1 Ω	1/2 w		Prec	1%
R956	323-630	72.4 Ω	1/2 w		Prec	1%
R957	323-629	43.1 Ω	1/2 w		Prec	1%
R958	323-628	28.6 Ω	1/2 w		Prec	1%
R960	323-636	50 k	1/2 w		Prec	1%
R962	323-627	21.4 Ω	1/2 w		Prec	1%
R964	323-638	50 k	1/2 w		Prec	1/4%
R965	323-637	50 Ω	1/2 w		Prec	1/4%
R969	308-242	.25 Ω	5 w		WW	5%

†Furnished as a unit with R778.

Parts List — Type 546

Resistors (Cont'd)

Ckt. No.	Tektronix Part No.		Description		S/N Range
R1000	316-820	82 Ω	1/4 w		
R1001	315-220	22 Ω	1/4 w		5%
R1002	301-101	100 Ω	1/2 w		5%
R1003	305-682	6.8 k	2 w		5%
R1004	311-086	2.5 k		Var	VERT DC BAL
R1011	315-220	22 Ω	1/4 w		5%
R1013	305-682	6.8 k	2 w		5%
R1014	301-131	130 Ω	1/2 w		5%
R1015	315-131	130 Ω	1/4 w		5%
R1016	315-300	30 Ω	1/4 w		5%
R1017	311-258	100 Ω		Var	VERT GAIN
R1018	305-273	27 k	2 w		5%
R1019	308-002	1.5 k	5 w		5%
R1024	301-131	130 Ω	1/2 w		5%
R1025	315-131	130 Ω	1/4 w		5%
R1026	315-300	30 Ω	1/4 w		5%
R1027	315-121	120 Ω	1/4 w		5%
R1031	315-512	5.1 k	1/4 w		5%
R1032	322-092	88.7 Ω	1/4 w		1%
R1034	315-100	10 Ω	1/4 w		5%
R1038	301-821	820 Ω	1/2 w		5%
R1041	315-512	5.1 k	1/4 w		5%
R1042	322-092	88.7 Ω	1/4 w		1%
R1048	301-821	820 Ω	1/2 w		5%
R1051	321-117	162 Ω	1/8 w		1%
R1061	321-117	162 Ω	1/8 w		1%
R1069	315-361	360 Ω	1/4 w		5%
R1071	315-360	36 Ω	1/4 w		5%
R1072	323-105	121 Ω	1/2 w		1%
R1073	301-331	330 Ω	1/2 w		5%
R1074	321-073	56.2 Ω	1/8 w		1%
R1076	311-442	250 Ω		Var	
R1077	315-163	16 k	1/4 w		5%
R1082	323-105	121 Ω	1/2 w		1%
R1083	301-331	330 Ω	1/2 w		5%
R1084	321-073	56.2 Ω	1/8 w		1%
R1087	304-122	1.2 k	1 w		
R1088	305-681	680 Ω	2 w		5%
R1089	308-296	1.2 k	5 w		5%
R1104	301-270	27 Ω	1/2 w		5%
R1105	323-102	113 Ω	1/2 w		1%
R1106	311-442	250 Ω		Var	
R1108	*310-603	600 Ω/300 Ω	3 w		2%
R1113	315-100	10 Ω	1/4 w		5%
R1114	*310-602	1 k	8 w		1%

Resistors (Cont'd)

Ckt. No.	Tektronix Part No.		Description		S/N Range
R1118	308-232	320 Ω	5 w	WW	5%
R1124	301-270	27 Ω	1/2 w		5%
R1126	321-204	1.3 k	1/8 w	Prec	1%
R1129	308-283	800 Ω	10 w	WW	5%
R1132	315-100	10 Ω	1/4 w		5%
R1134	*310-602	1 k	8 w	WW	1%
R1141	322-092	88.7 Ω	1/4 w	Prec	1%
R1142	315-331	330 Ω	1/4 w		5%
R1144	301-681	680 Ω	1/2 w		5%
R1151	322-092	88.7 Ω	1/4 w	Prec	1%
R1152	315-331	330 Ω	1/4 w		5%
R1153	315-100	10 Ω	1/4 w		5%
R1154	301-681	680 Ω	1/2 w		5%
R1156	315-820	82 Ω	1/4 w		5%
R1157	315-361	360 Ω	1/4 w		5%
R1161	315-221	220 Ω	1/4 w		5%
R1163	308-258	6 k	3 w	WW	5%
R1165	315-820	82 Ω	1/4 w		5%
R1166	302-221	220 Ω	1/2 w		
R1169	302-105	1 meg	1/2 w		
R1173	308-258	6 k	3 w	WW	5%
R1175	315-820	82 Ω	1/4 w		5%
R1181	315-105	1 meg	1/4 w		5%
R1184	301-334	330 k	1/2 w		5%
R1187	301-334	330 k	1/2 w		5%
R1191	315-105	1 meg	1/4 w		5%
R1194	301-334	330 k	1/2 w		5%

Switches

	Unwired	Wired			
SW1	260-495	*262-598	(B Triggering)	Lever	SOURCE COUPLING SLOPE MODE PULL FOR X10 RANGE INCREASE
SW5	260-494			Lever	
SW10	260-542			Lever	
SW75	260-493			Lever	
SW15†	311-426			Lever	
SW90	260-531	*262-596		Rotary	"B" TIME/CM OR DELAY TIME
SW90Z††	311-391				
SW201	260-495	*262-597	(A Triggering)	Lever	SOURCE COUPLING SLOPE MODE
SW205	260-494			Lever	
SW210	260-542			Lever	
SW375	260-493			Lever	

†Furnished as a unit with R15.

††Furnished as a unit with R90Z.

Parts List — Type 546

Switches (Cont'd)

Ckt. No.	Tektronix Part No.		Description	S/N Range
	Unwired	Wired		
SW215†	311-426			
SW290	260-530	*262-595	Rotary	PULL FOR X10 RANGE INCREASE A TIME/CM
SW290Z††	311-391			
SW369	260-496	*262-602	Lever	SINGLE SWEEP RESET
SW135	260-516		Push	
SW530	260-533	*262-604	Rotary	HORIZONTAL DISPLAY rear HORIZONTAL DISPLAY front
SW557	260-532	*262-603	Rotary	
SW601	260-199		Toggle	POWER ON
SW673	260-516		Push	
SW858	260-209		Toggle	CRT CATHODE SELECTOR
SW950	260-536	*262-599	Rotary	AMPLITUDE CALIBRATOR COMPENSATION
SW1000	260-601		Slide	
TK601	260-336		Thermal Cutout 150°F ±5°F	

Transformers

T52	*120-323	2T-8T Bifilar
T252	*120-323	2T-8T Bifilar
T601	*120-307	L.V. Power
T801	*120-308	H.V. Power
T1030	*120-341	Toroid 3T Bifilar
T1104	276-541	Core, Ferrite

Electron Tubes

V24	154-187	6DJ8
V91	154-040	12AU6
V93	154-187	6DJ8
V145	154-187	6DJ8
V193	154-187	6DJ8
V224	154-187	6DJ8
V291	154-022	6AU6
V293	154-187	6DJ8
V345	154-187	6DJ8
V393	154-187	6DJ8
V404	154-187	6DJ8
V514	154-187	6DJ8
V574	154-187	6DJ8
V584	154-187	6DJ8
V589	154-146	6197

†Furnished as a unit with R215.

††Furnished as a unit with R290Z.

Electron Tubes (Cont'd)

Ckt. No.	Tektronix Part No.	Description	S/N Range
V609	154-291	OG3	
V624	154-043	12AX7	
V634	154-022	6AU6	
V637	154-202	6CW5	
V647	154-202	6CW5	
V664	154-414	6BY8	
V677	154-056	6080	
V684	154-043	12AX7	
V694	154-022	6AU6	
V707	154-056	6080	
V724	154-022	6AU6	
V737	154-202	6CW5	
V764	154-187	6DJ8	
V800	154-021	6AU5	
V814	154-041	12AU7	
V822	154-051	5642	
V832	154-051	5642	
V842	154-051	5642	
V852	154-051	5642	
V859	*154-429	T5470-31-2 Crt Standard Phosphor	
V862	154-051	5642	
V935	154-041	12AU7	
V945	154-022	6AU6	
V1003	154-039	12AT7	
V1184	154-043	12AX7	

IMPORTANT:

All circuit voltages were obtained with a 20,000 Ω /Volt VOM.

All readings are in volts. The voltages were measured with respect to ground unless otherwise indicated by the use of arrows to point out voltage drop.

Waveforms were obtained using a Type 530-Series Oscilloscope with a Type L Plug-In Unit and 10X attenuator probe. An equivalent oscilloscope having a vertical passband of dc to 10 mc or better and equal sensitivity can be used as a test oscilloscope.

Waveform dc levels with respect to ground are indicated at the right side of waveform; measured when test oscilloscope AC-DC switch was set to DC.

Waveforms were photographed with test oscilloscope AC-DC switch set to AC; vertical deflection factor and Time/Cm switch set to those settings indicated adjacent to waveforms.

In most cases +Ext. AC triggering on the Type 546 1-kc AMPLITUDE CALIBRATOR signal was used. Exception: +Int. triggering mode is also used; this mode, if used, is indicated above the waveform.

NOTE

Number of cycles displayed by waveform when calibrator signal was used as a trigger source depends mostly on the signal repetition rate. Though +Ext. triggering was used, a time difference of 1 msec can occur between waveforms because the test oscilloscope can trigger on a different cycle than the Type 546 and vice versa.

Voltage and waveform measurements are not absolute. They may vary between instruments due to normal manufacturing tolerances, and transistor and vacuum tube characteristics.

The plug-in unit used in the Type 546 Oscilloscope during the voltage and waveform measurements is a Type TU-7 Test Unit. Its front-panel control settings and other conditions are as follows:

Input Signal	None
Position	Centered
	(Exception: See Vertical Amplifier schematic diagram)
Test Function	Low Load

Any letter-series or 1-series plug-in unit or the TU-2 can be used in place of the Type TU-7 when troubleshooting the Type 546.

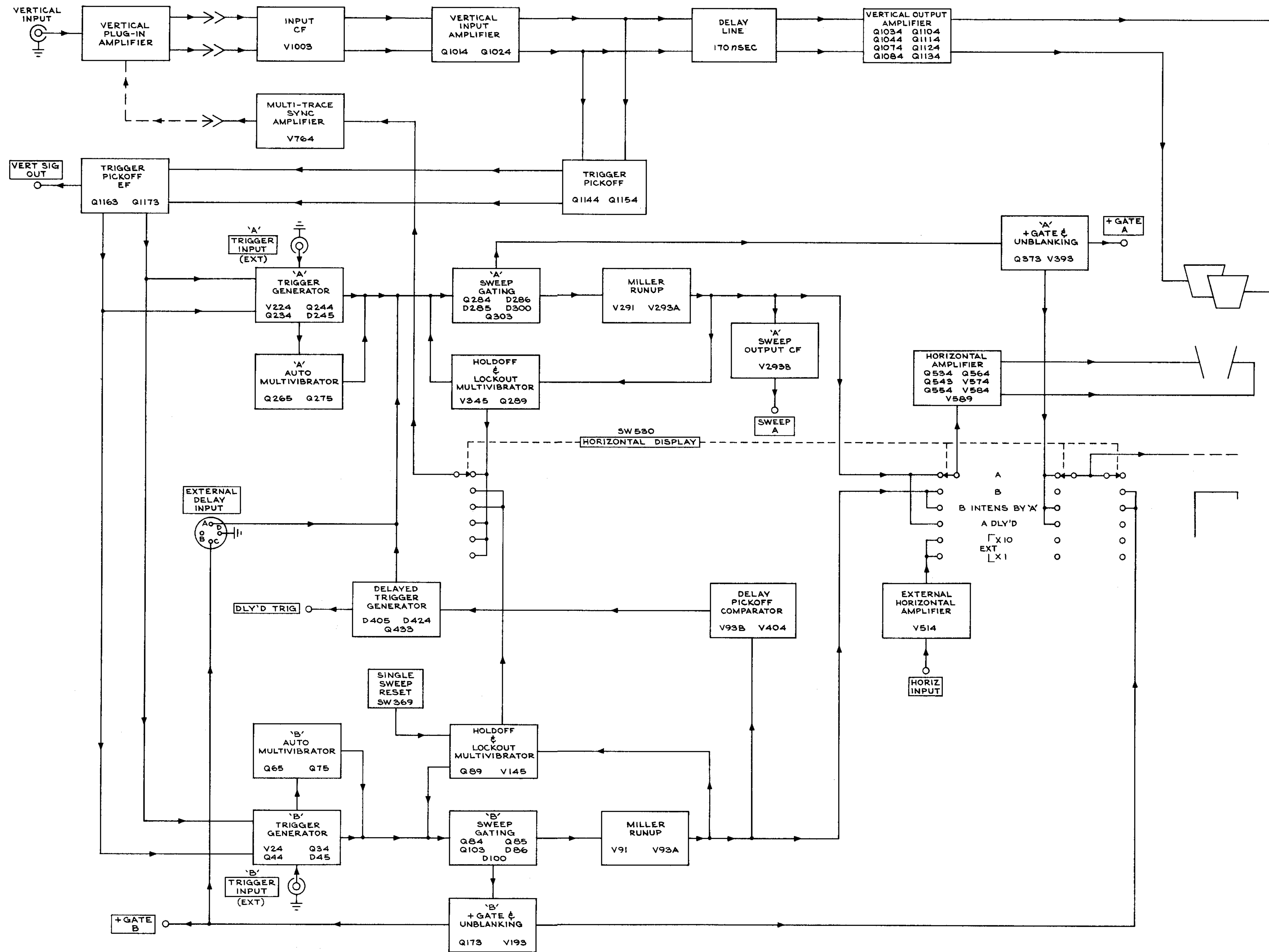

POWER SUPPLY

VOLTAGE READINGS WERE OBTAINED under the following conditions:

LINE VOLTAGE 115 VAC (or Design Center)

INPUT SIGNAL None

'A' AND 'B' TRIGGER INPUT Signal None

'A' AND 'B' TRIGGERING LEVEL ccw

'A' AND 'B' TRIGGERING MODE TRIG

'A' AND 'B' TRIGGERING SOURCE EXT

AMPLITUDE CALIBRATOR OFF

POWER ON

Also see IMPORTANT note on Block Diagram.

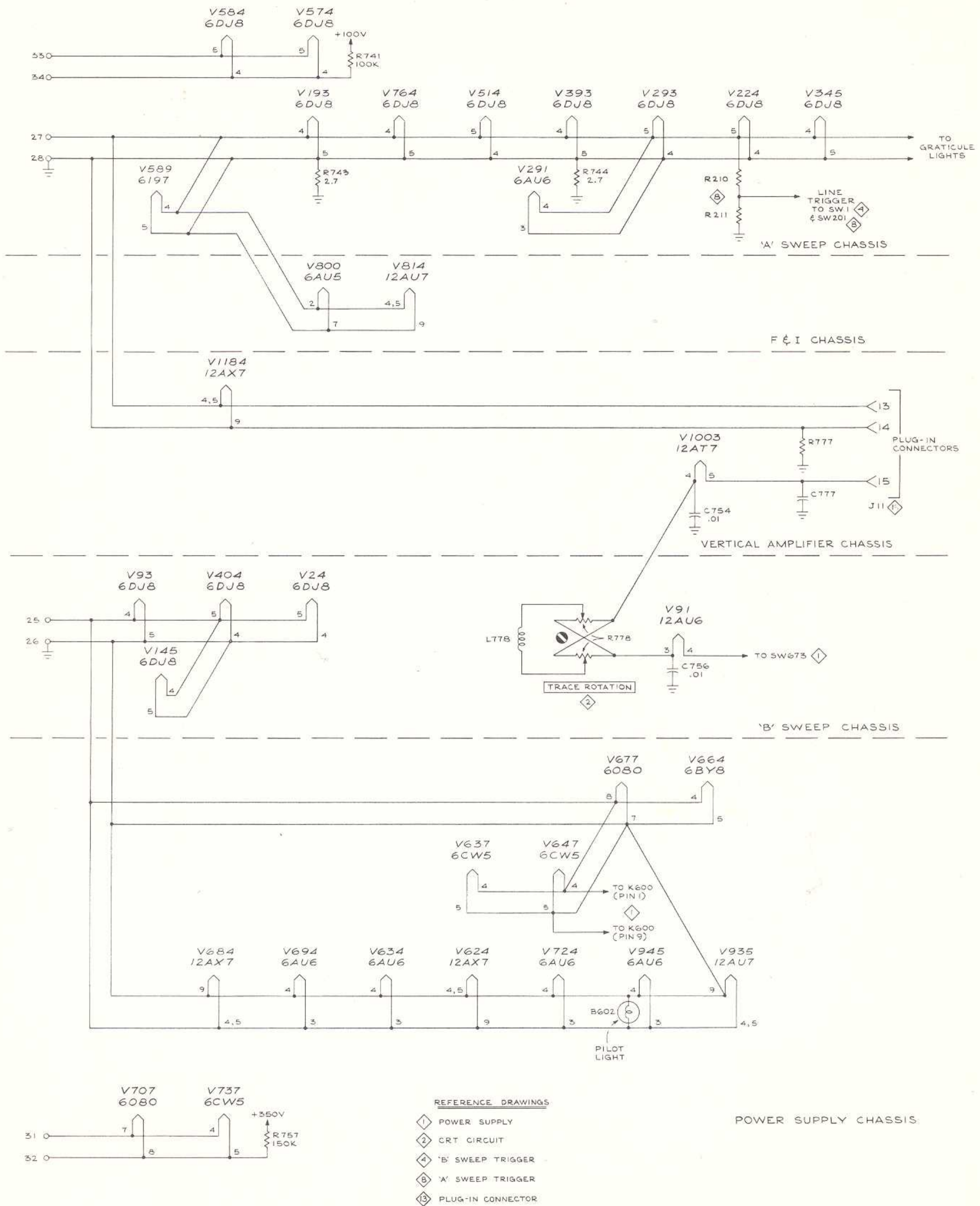

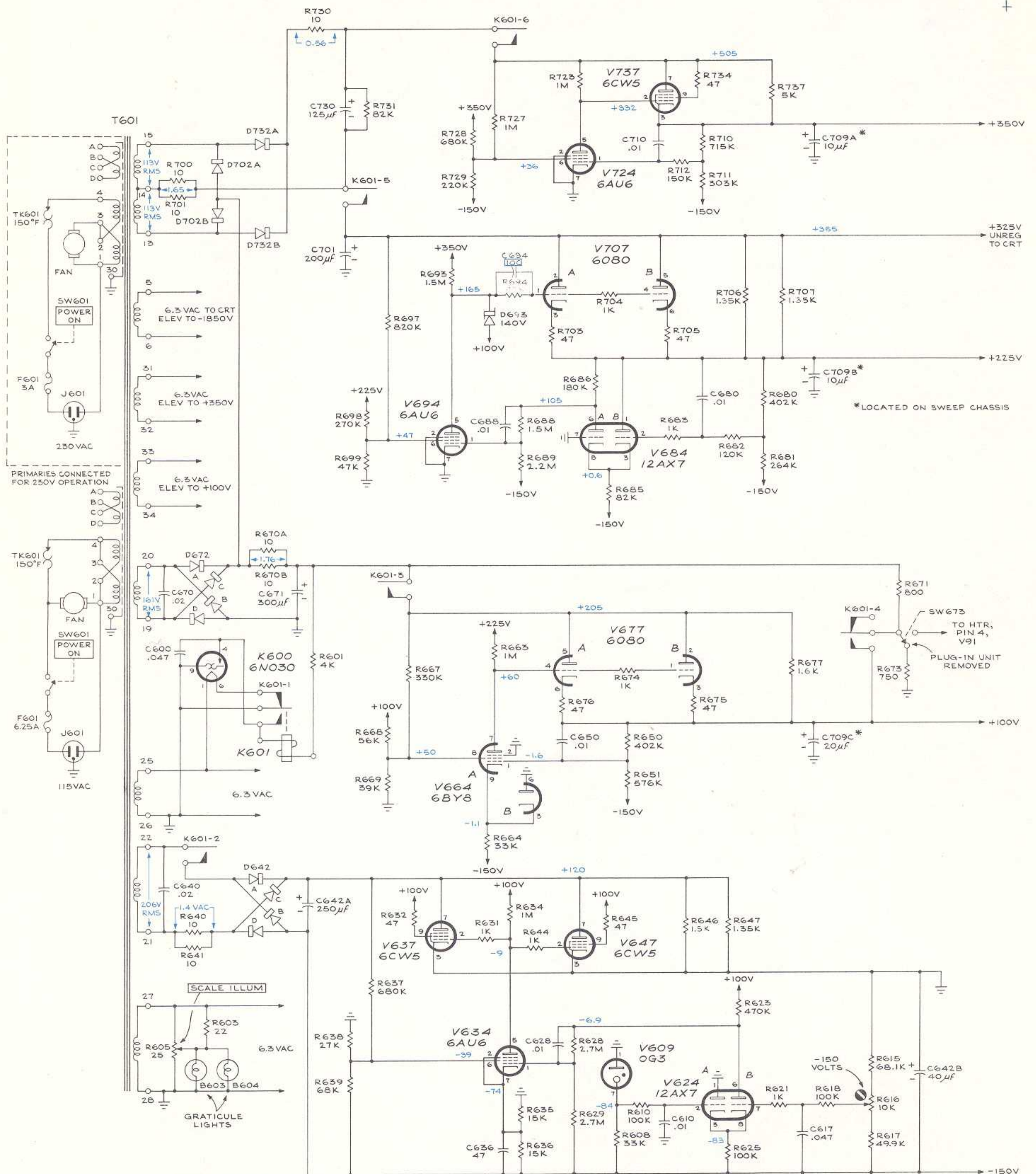

SEE PARTS LIST FOR EARLIER VALUES AND SERIAL NUMBER RANGES OF PARTS MARKED WITH BLUE OUTLINE.

B

CRT CIRCUIT

WAVEFORM AND DYNAMIC VOLTAGE READINGS were obtained under the following conditions:

INTENSITY ccw

POWER ON

- * Voltage reading obtained with associated control set for normal operation. Voltage is dependent on position of the control.

Also see IMPORTANT note on Block Diagram.

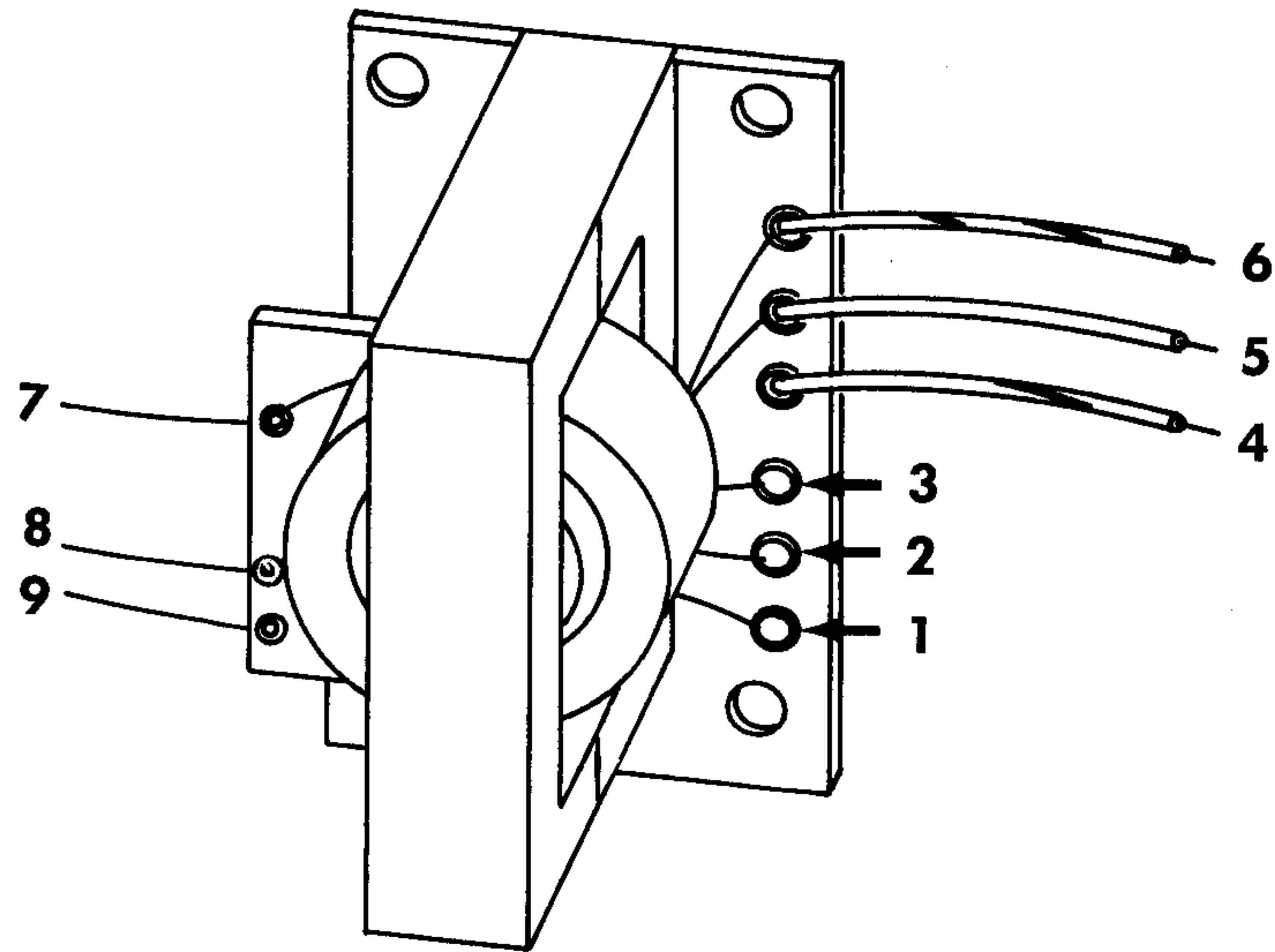

T801 TRANSFORMER DETAILS

T801 TRANSFORMER DETAILS

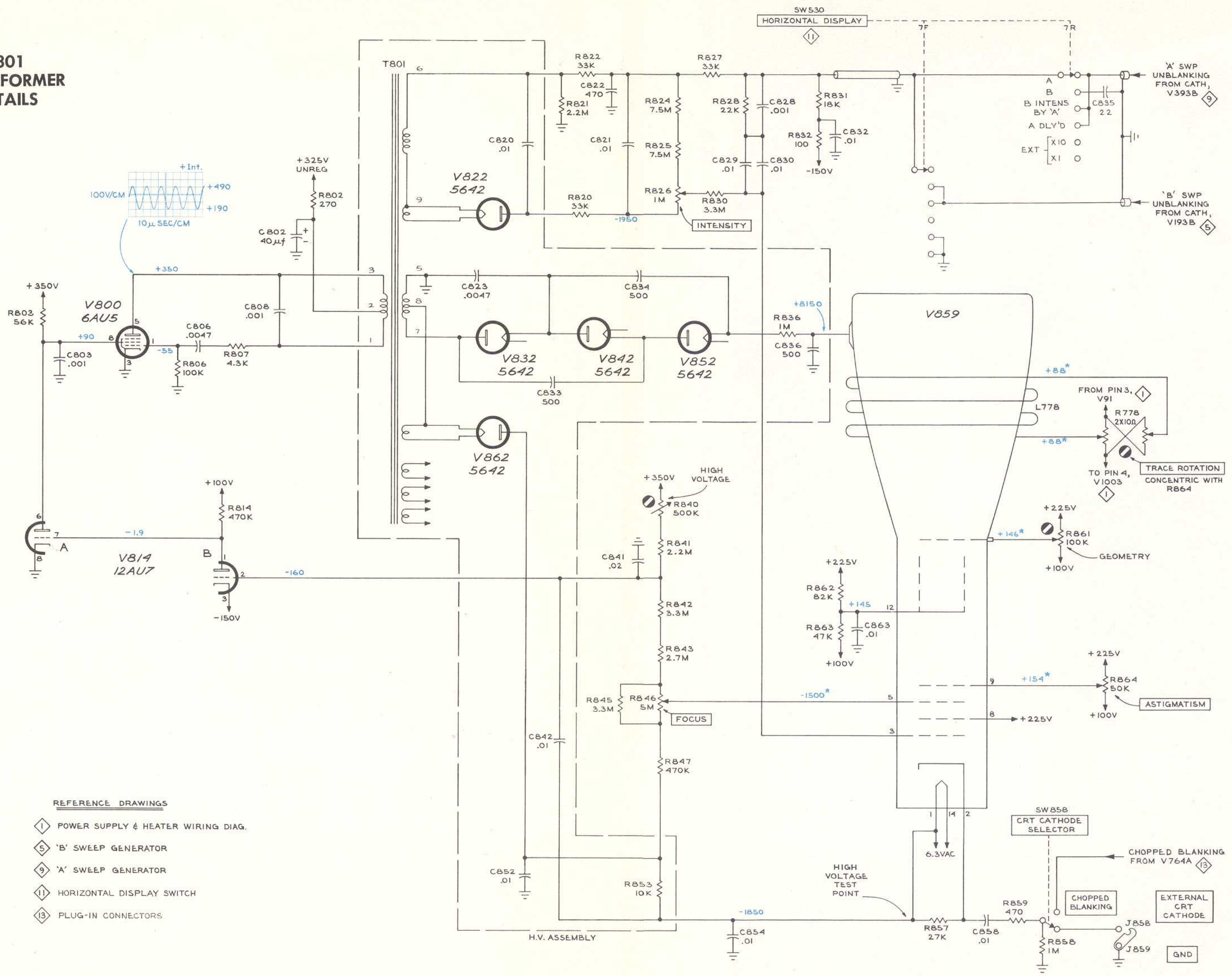

- REFERENCE DRAWINGS**
- ① POWER SUPPLY & HEATER WIRING DIAG.
 - ⑤ 'B' SWEEP GENERATOR
 - ⑨ 'A' SWEEP GENERATOR
 - ⑪ HORIZONTAL DISPLAY SWITCH
 - ⑬ PLUG-IN CONNECTORS

TYPE 546 OSCILLOSCOPE

CRT CIRCUIT ②

CMD
664

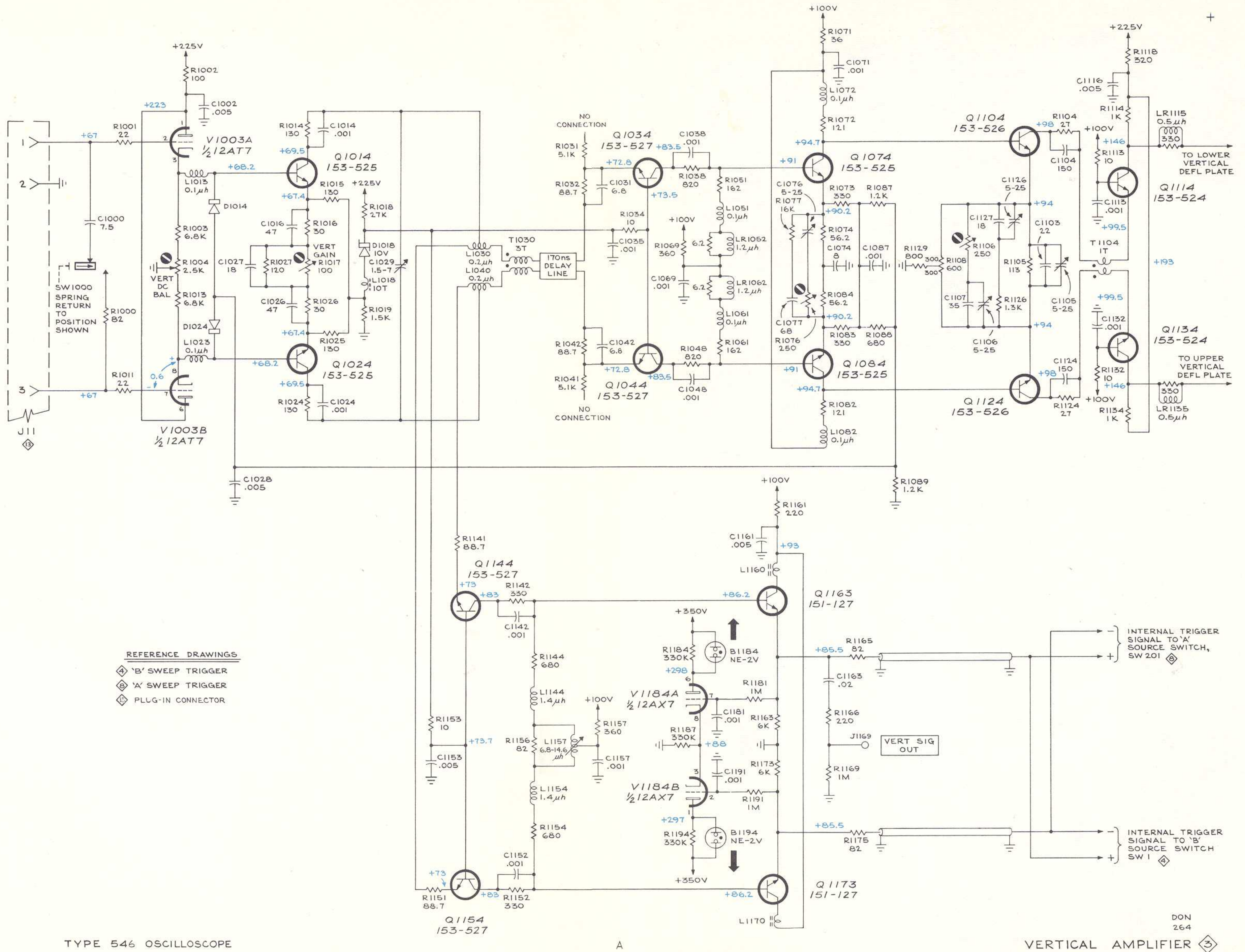

REFERENCE DRAWINGS

- ⊠ 'B' SWEEP TRIGGER
- ⊠ 'A' SWEEP TRIGGER
- ⊠ PLLG-IN CONNECTOR

TYPE 546 OSCILLOSCOPE

A

VERTICAL AMPLIFIER

DON
264

'B' SWEEP TRIGGER

WAVEFORMS AND VOLTAGE READINGS were obtained under the following conditions:

TIME BASE A —

TRIGGER INPUT Signal None

TRIGGERING:

MODE TRIG

SOURCE EXT

MAIN TIME BASE (B) —

TRIGGERING:

MODE TRIG

SLOPE +

COUPLING AC

SOURCE EXT

HORIZONTAL DISPLAY B

POWER ON

WAVEFORM Conditions —

'B' TRIGGER INPUT Signal 10 Volts P-P Calibrator

'B' TRIGGERING LEVEL +45°; knob pushed in

'B' TIME/CM1 mSEC

AMPLITUDE CALIBRATOR 10 Volts

QUIESCENT VOLTAGE Conditions —

'B' TRIGGER INPUT Signal None

'B' TRIGGERING LEVEL with knob pushed in:

Upper Voltage Readings ccw

Lower Voltage Readings cw

Also see IMPORTANT note on Block Diagram.

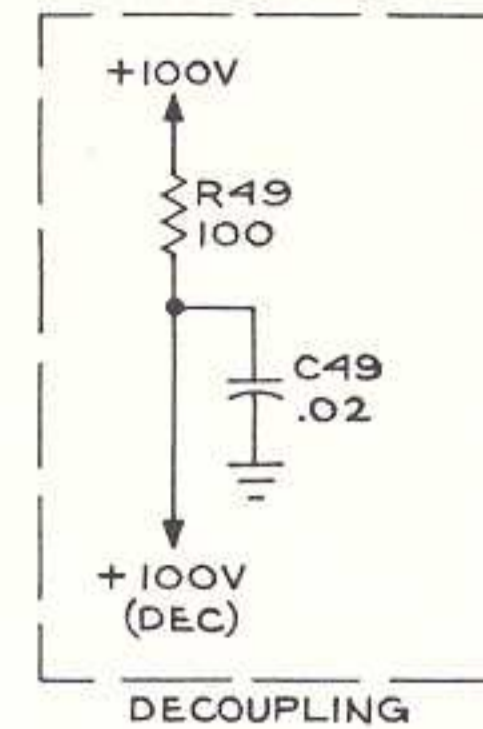
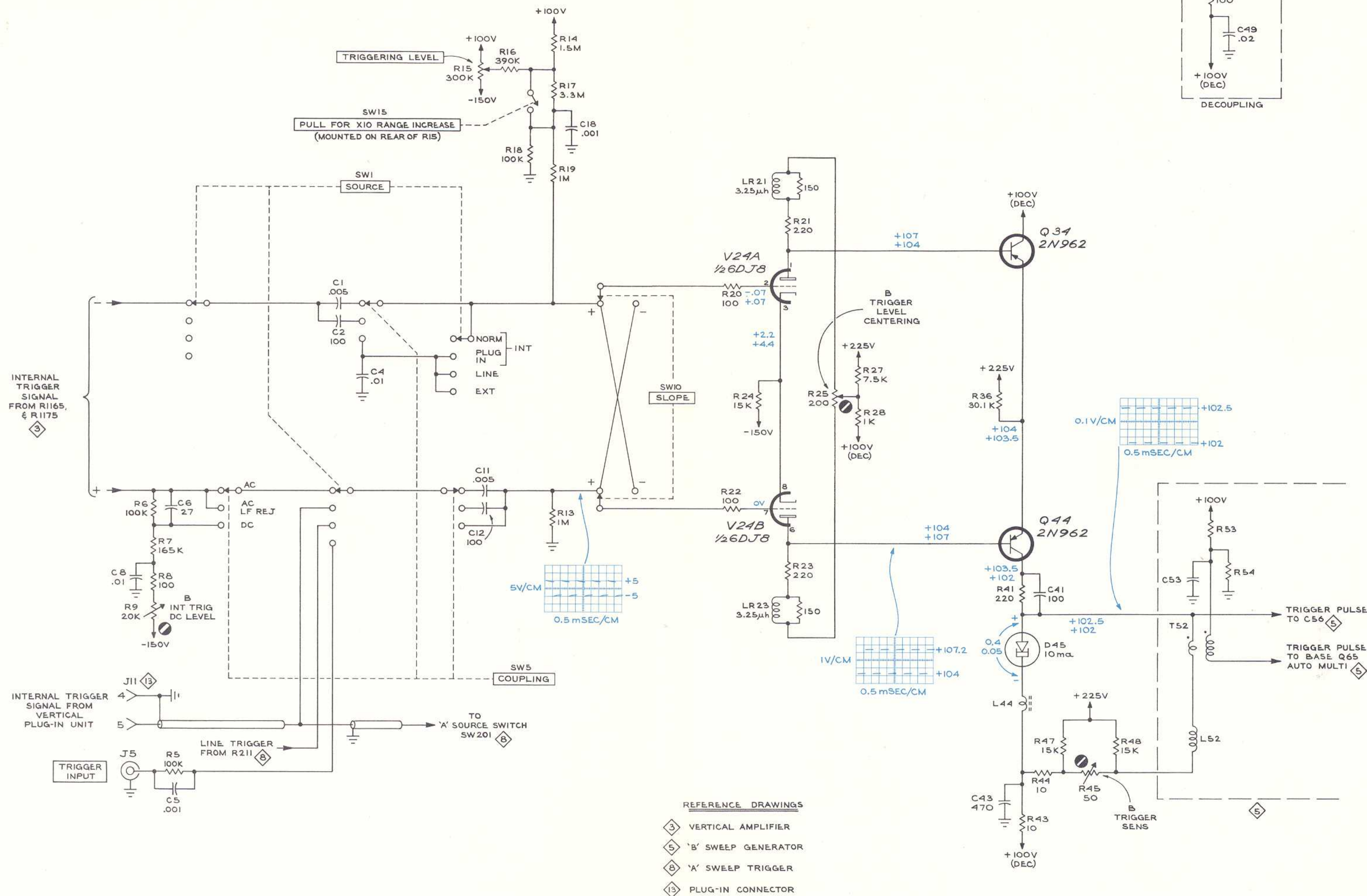

- REFERENCE DRAWINGS
- ③ VERTICAL AMPLIFIER
 - ⑤ 'B' SWEEP GENERATOR
 - ⑥ 'X' SWEEP TRIGGER
 - ⑬ PLUG-IN CONNECTOR

TYPE 546 OSCILLOSCOPE

CMD 264
B' SWEEP TRIGGER ④

'B' SWEEP GENERATOR

WAVEFORMS AND VOLTAGE READINGS were obtained under the following conditions:

TIME BASE A —

TRIGGER INPUT Signal None

TRIGGERING:

MODE TRIG

SOURCE EXT

HORIZONTAL DISPLAY B

SINGLE SWEEP Switch NORMAL

MAIN TIME BASE (B)

TRIGGERING LEVEL +45°; pushed in

TRIGGERING:

SLOPE +

COUPLING AC

SOURCE EXT

BRIGHTNESS cw

TIME/CM1 mSEC

VARIABLE (TIME/CM) CALIBRATED

POWER ON

WAVEFORM CONDITIONS —

'B' TRIGGER INPUT SIGNAL 10 Volts P-P Calibrator

'B' TRIGGERING MODE TRIG (AUTO for waveforms at collectors of Q65 and Q75).

AMPLITUDE CALIBRATOR 10 Volts

QUIESCENT VOLTAGE CONDITIONS —

'B' TRIGGER INPUT SIGNAL None

'B' TRIGGERING MODE TRIG

Also see IMPORTANT note on Block Diagram.

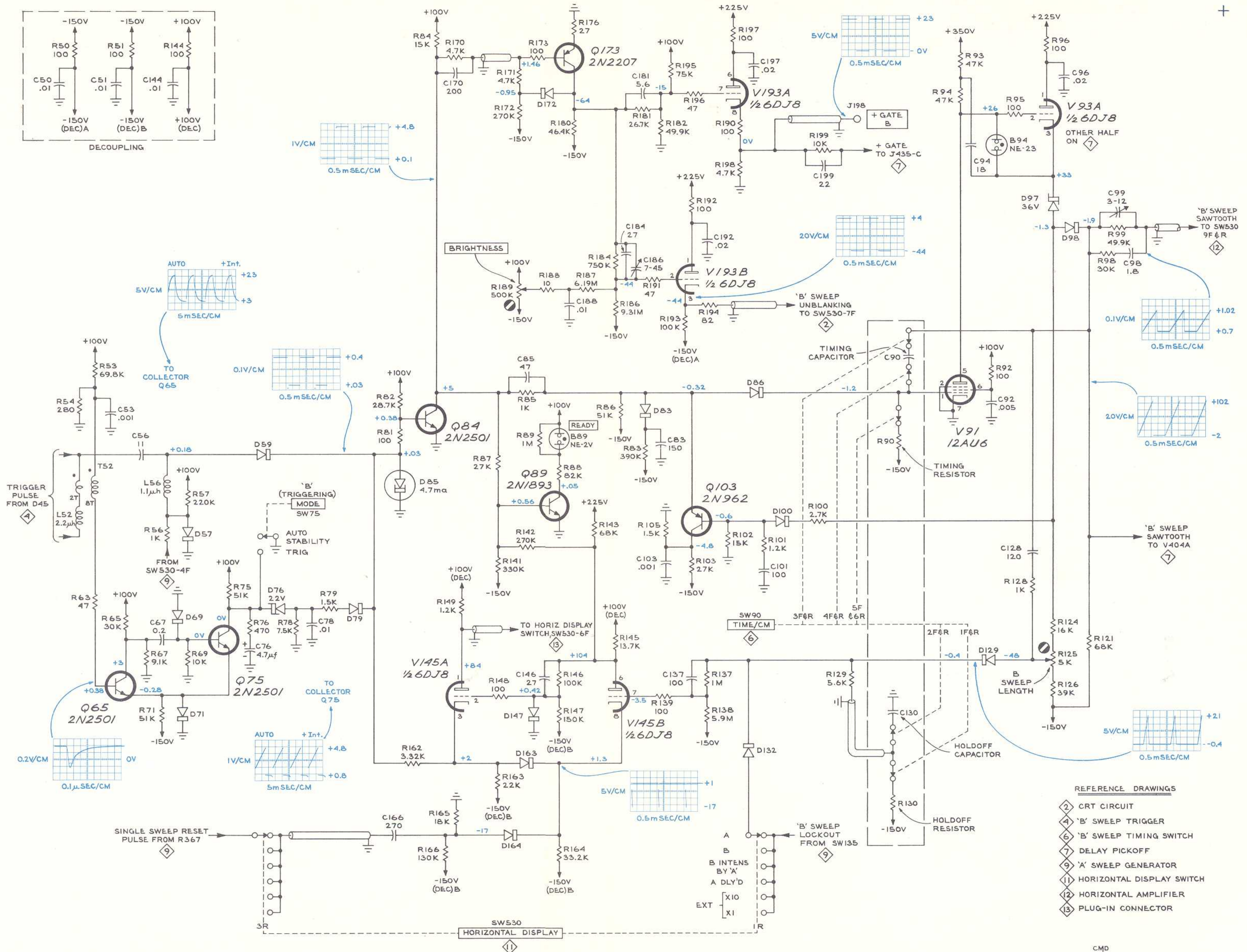
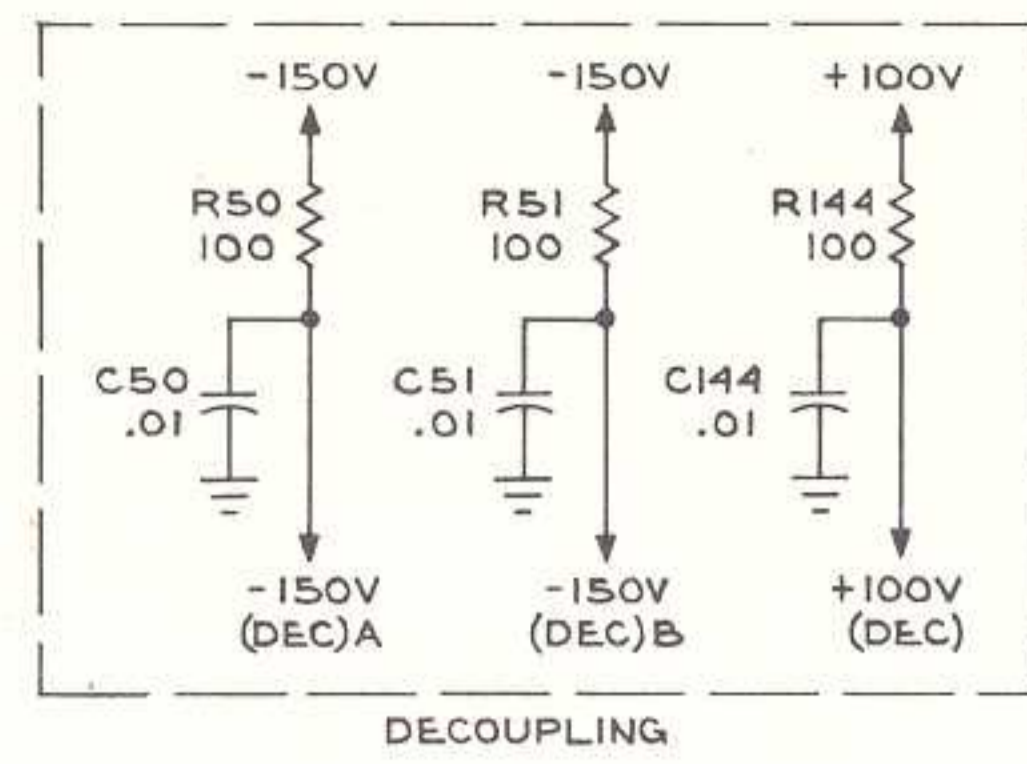

- REFERENCE DRAWINGS
- ⑤ CRT CIRCUIT
 - ④ 'B' SWEEP TRIGGER
 - ⑥ 'B' SWEEP TIMING SWITCH
 - ⑦ DELAY PICKOFF
 - ⑨ 'A' SWEEP GENERATOR
 - ⑪ HORIZONTAL DISPLAY SWITCH
 - ⑫ HORIZONTAL AMPLIFIER
 - ⑬ PLUG-IN CONNECTOR

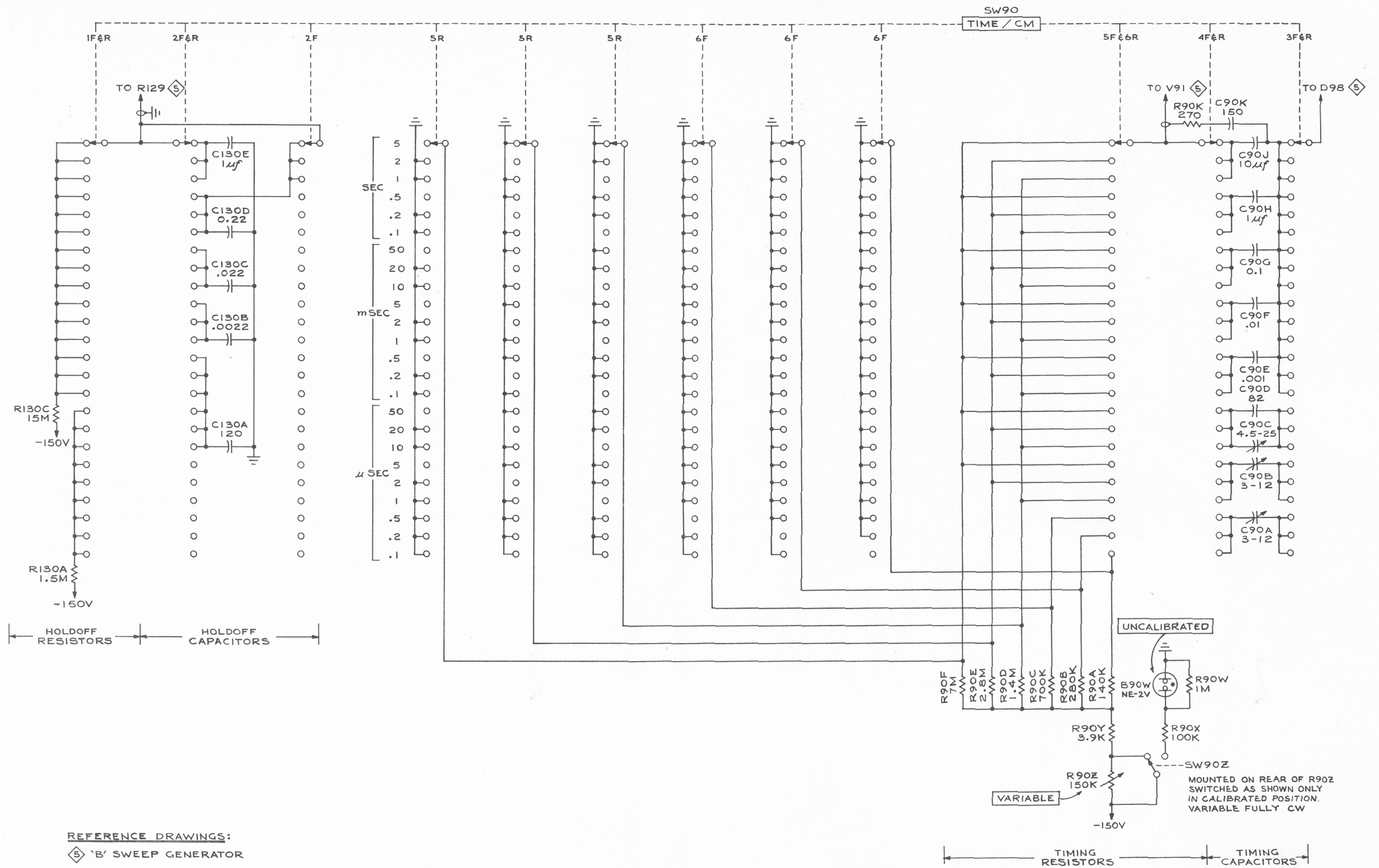

DELAY PICKOFF

WAVEFORMS AND VOLTAGE READINGS were obtained under the following conditions:

TIME BASE A —

'A' TRIGGER INPUT Signal None
'A' TRIGGERING LEVEL ccw
TIME/CM1 mSEC/CM
VARIABLE CALIBRATED

SINGLE SWEEP Switch NORMAL

MAIN TIME BASE (B) —

TRIGGERING LEVEL +45°; push in
TRIGGERING:
MODE TRIG
SLOPE +
COUPLING AC
SOURCE EXT
TIME/CM1 mSEC/CM
VARIABLE CALIBRATED

DELAY-TIME MULTIPLIER 2.00

POWER ON

WAVEFORM CONDITIONS —

'A' TRIGGERING MODE AUTO
HORIZONTAL DISPLAY A DLY'D
'B' TRIGGER INPUT Signal 10 Volts P-P Calibrator
AMPLITUDE CALIBRATOR 10 Volts

QUIESCENT VOLTAGE CONDITIONS —

'A' TRIGGERING MODE TRIG
HORIZONTAL DISPLAY B
'B' TRIGGER INPUT Signal None

Also see IMPORTANT note on Block Diagram.

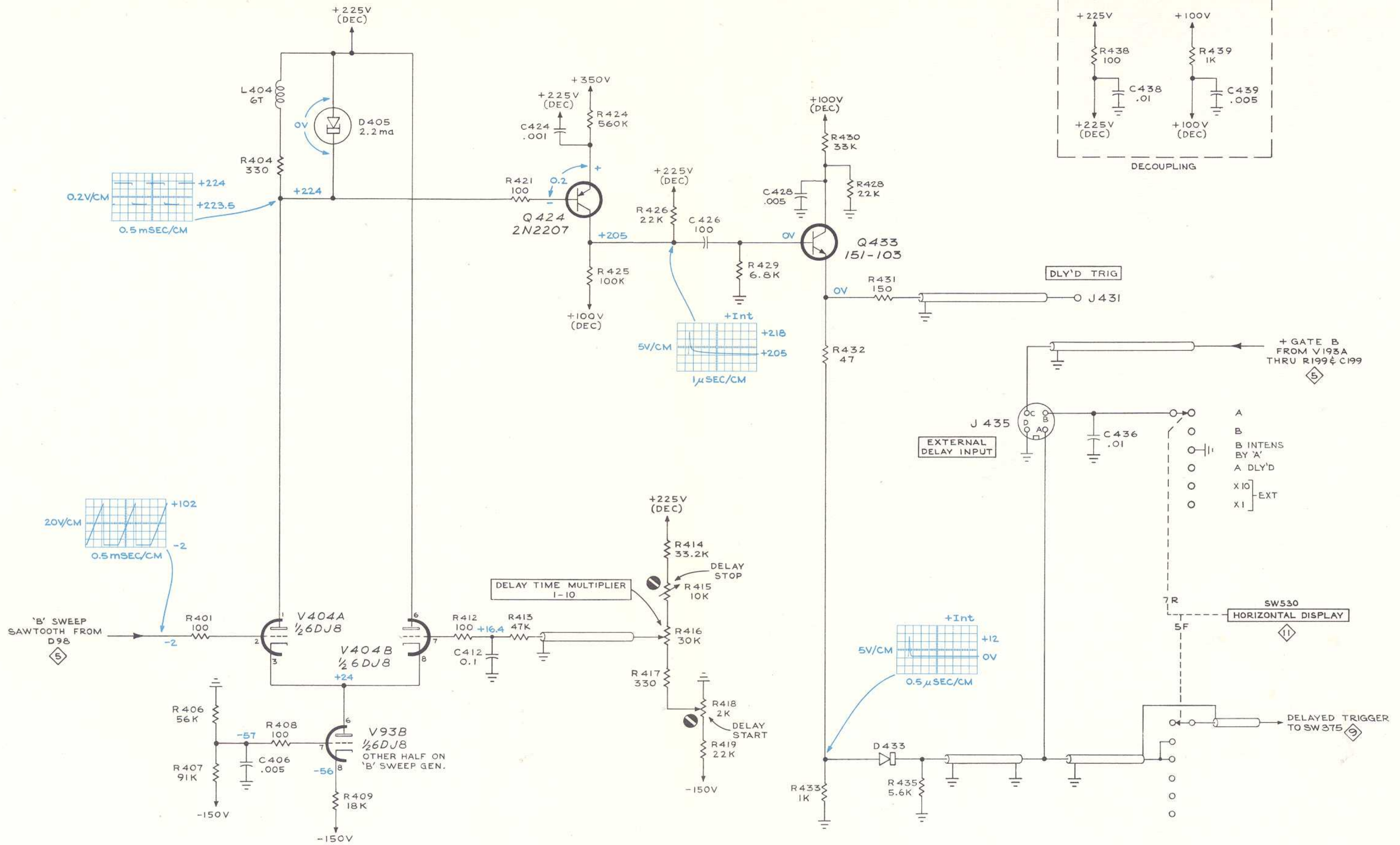

REFERENCE DRAWINGS

- 5 'B' SWEEP GENERATOR
- 9 'A' SWEEP GENERATOR
- 11 HORIZONTAL DISPLAY SWITCH

'A' SWEEP TRIGGER

WAVEFORMS AND VOLTAGE READINGS were obtained under the following conditions:

TIME BASE A —

TRIGGERING:

MODE	TRIG
SLOPE	+
COUPLING	AC
SOURCE	EXT

MAIN TIME BASE (B) —

TRIGGER INPUT Signal	None
MODE	TRIG
SOURCE	EXT

HORIZONTAL DISPLAY

A

POWER

ON

WAVEFORM CONDITIONS —

'A' TRIGGER INPUT Signal	10 Volts P-P Calibrator
'A' TRIGGERING LEVEL	+45°; knob pushed in
'A' TIME/CM1 mSEC
AMPLITUDE CALIBRATOR	10 Volts

QUIESCENT VOLTAGE CONDITIONS —

'A' TRIGGER INPUT Signal	None
'A' TRIGGERING LEVEL with knob pushed in:	
Upper Voltage Readings	ccw
Lower Voltage Readings	cw

Also see IMPORTANT note on Block Diagram.

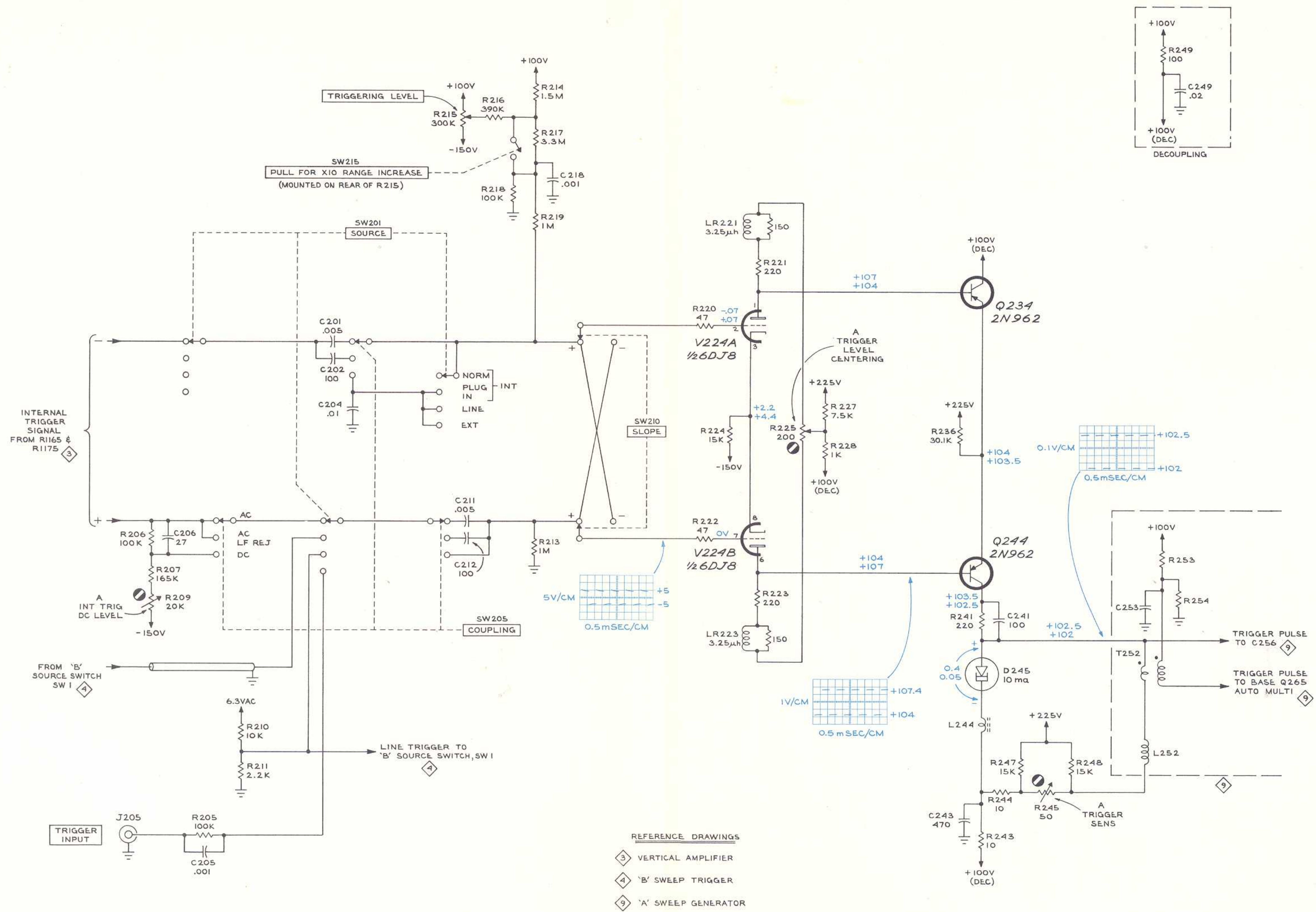

- REFERENCE DRAWINGS
- 3 VERTICAL AMPLIFIER
 - 4 'B' SWEEP TRIGGER
 - 9 'A' SWEEP GENERATOR

TYPE 546 OSCILLOSCOPE

CMD
264

'A' SWEEP TRIGGER 8

'A' SWEEP GENERATOR

WAVEFORMS AND VOLTAGE READINGS were obtained under the following conditions:

TIME BASE A —

TRIGGERING LEVEL +45°; knob pushed in
TRIGGERING:
SLOPE +
COUPLING AC
SOURCE EXT
TIME/CM1 mSEC
VARIABLE CALIBRATED

HORIZONTAL DISPLAY A

SINGLE SWEEP Switch NORMAL

MAIN TIME BASE (B) —

TRIGGER INPUT Signal None
TRIGGERING:
MODE TRIG
SOURCE EXT

POWER ON

WAVEFORM CONDITIONS —

'A' TRIGGER INPUT Signal 10 Volts P-P Calibrator
'A' TRIGGERING MODE TRIG (AUTO for waveforms at
collectors of Q265 and Q275).
AMPLITUDE CALIBRATOR 10 Volts

QUIESCENT VOLTAGE CONDITIONS

'A' TRIGGER INPUT Signal None
'A' TRIGGERING MODE TRIG

Also see IMPORTANT note on Block Diagram.

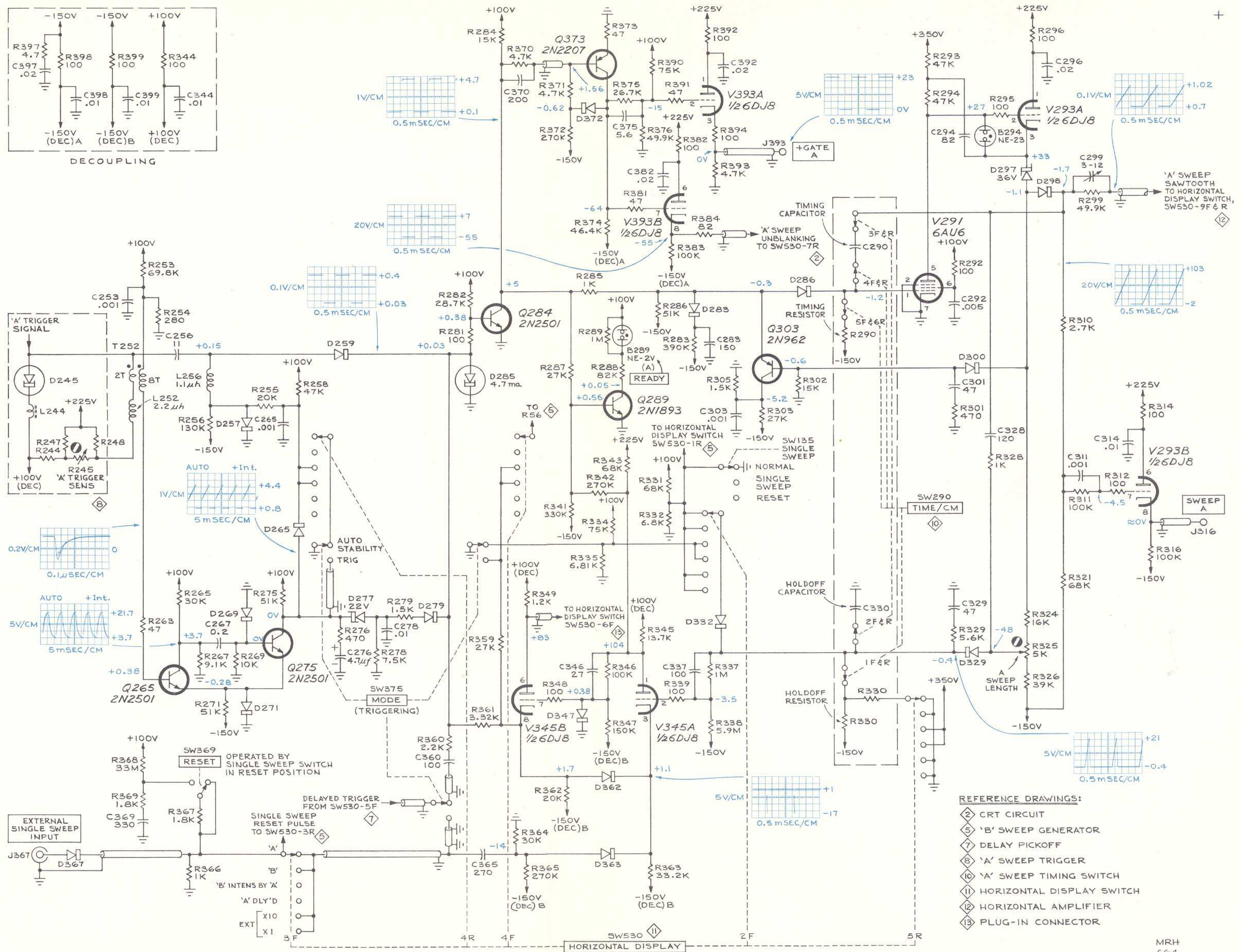
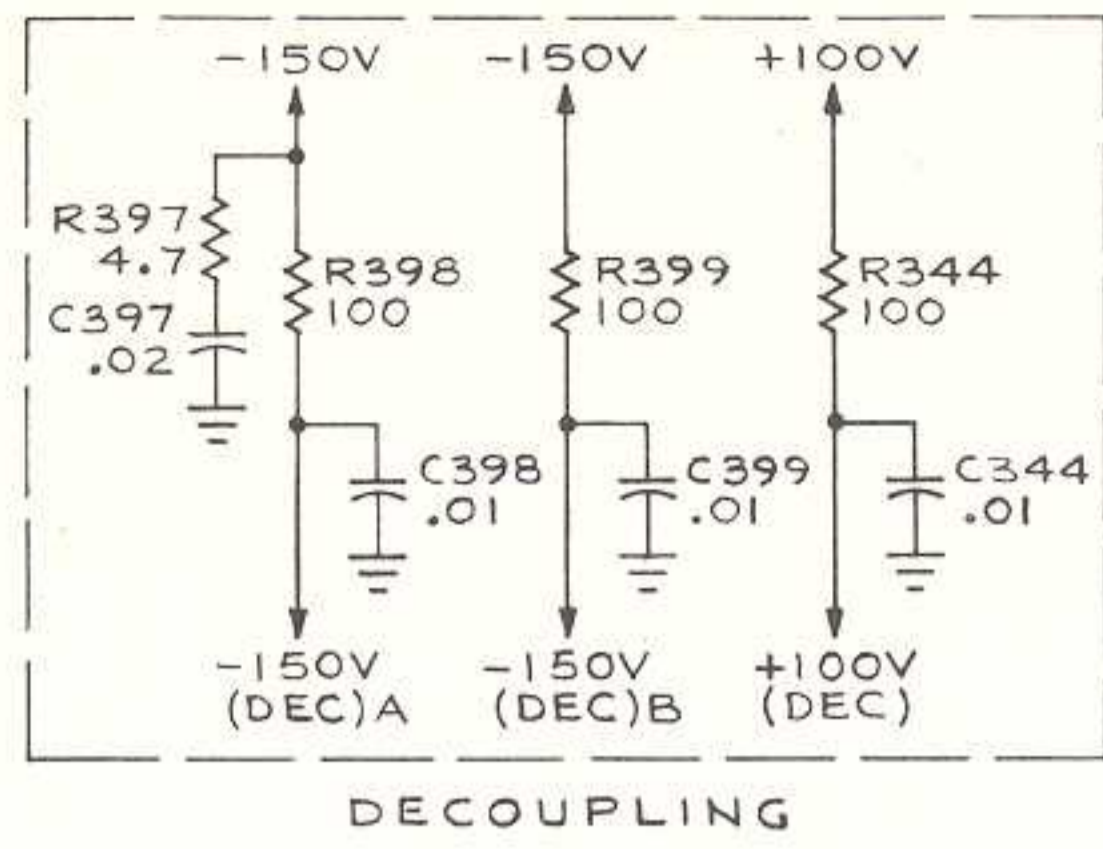

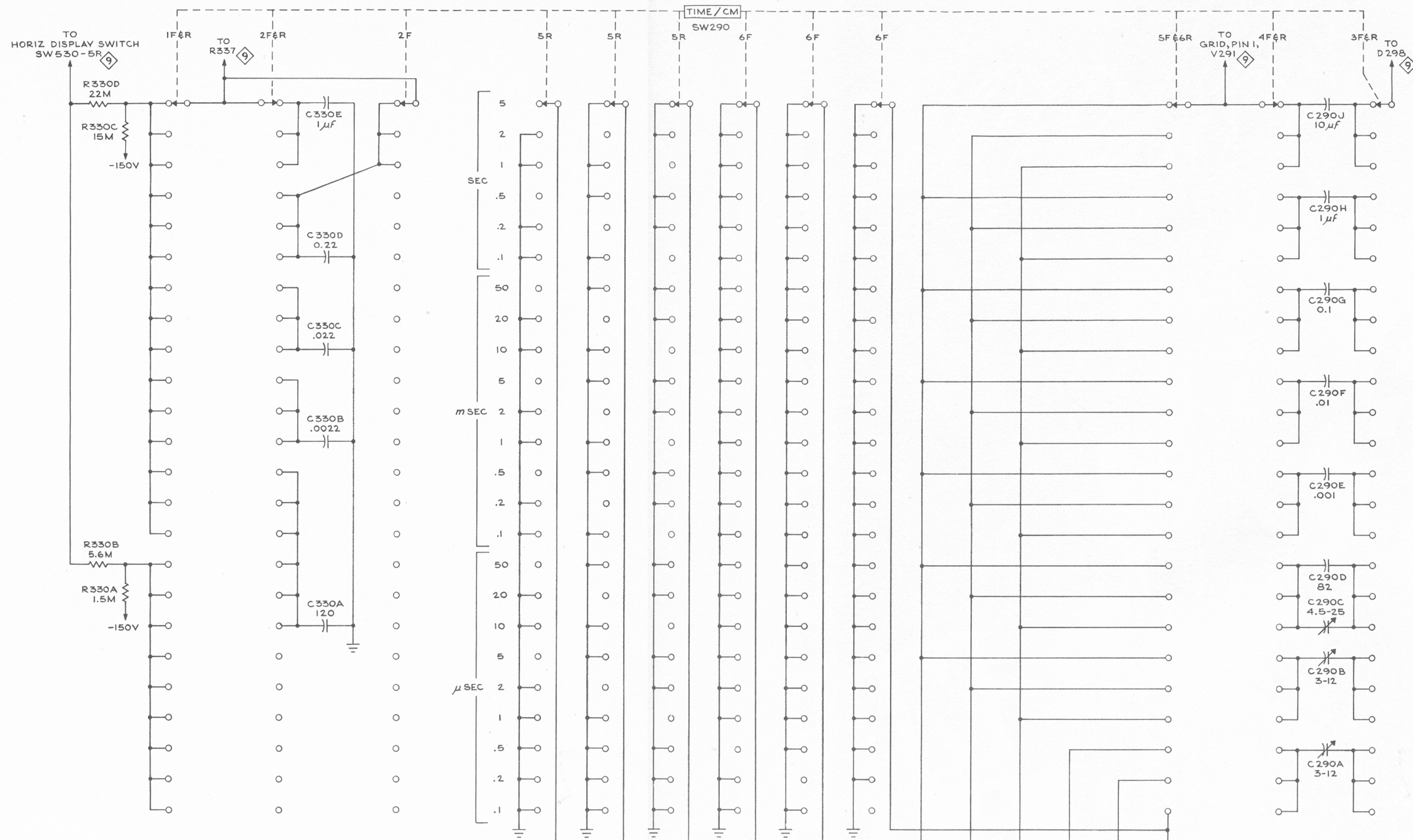

TYPE 546 OSCILLOSCOPE

REFERENCE DRAWINGS

9 'A' SWEEP GENERATOR

A₁

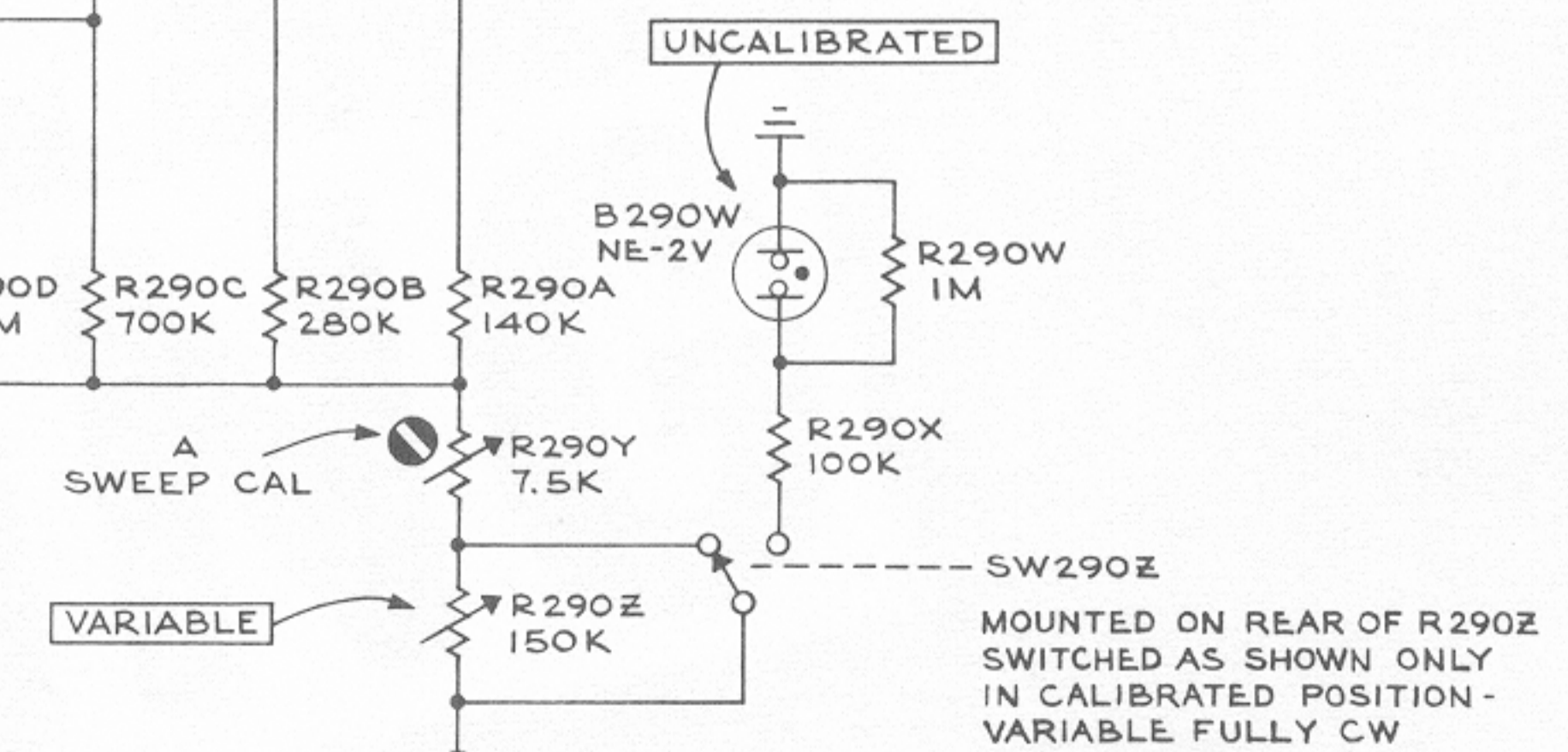

'A' SWEEP TIMING SWITCH 10

DON
664

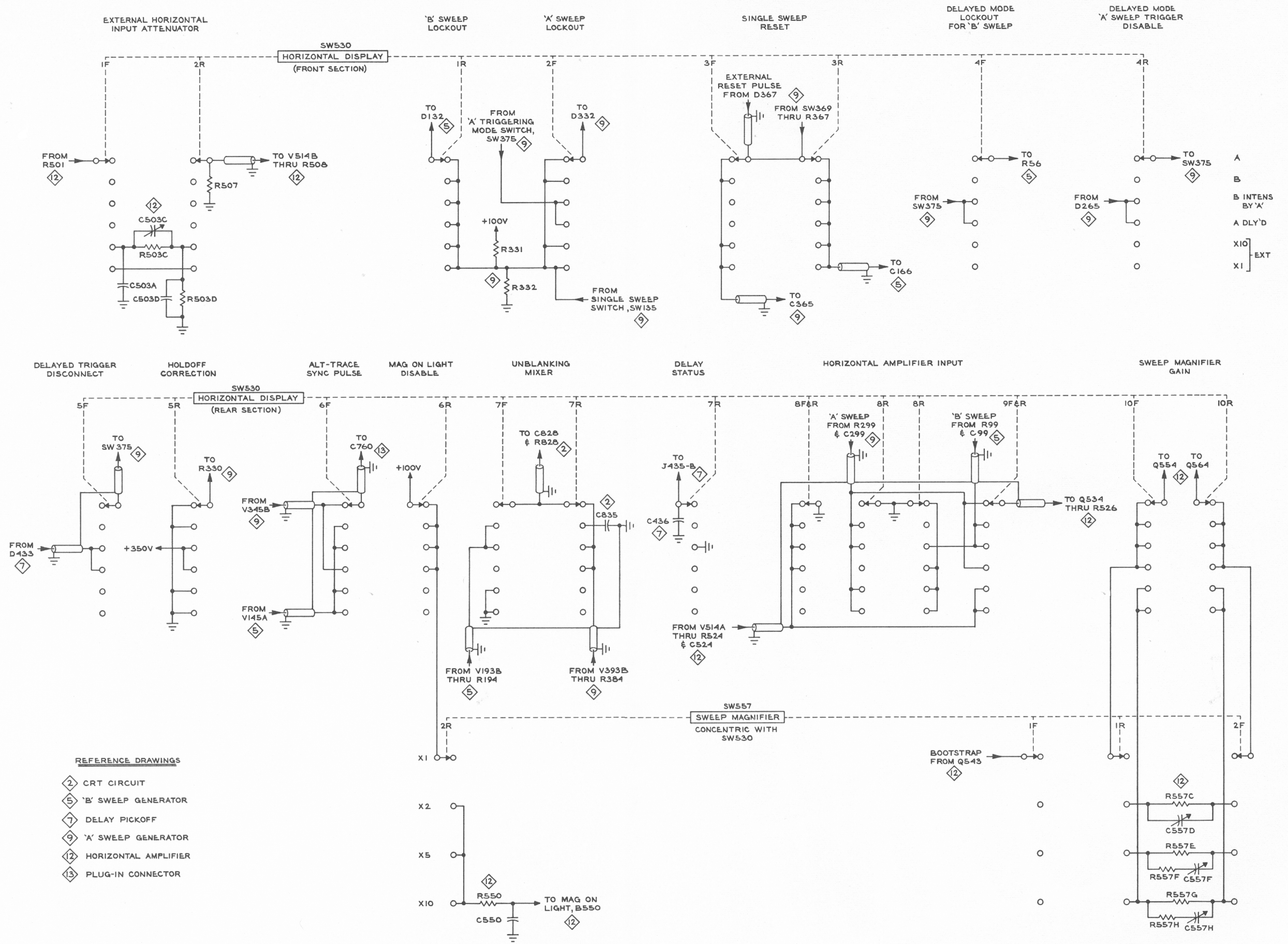

TYPE 546 OSCILLOSCOPE

HORIZONTAL DISPLAY SWITCH ⑪

CMD
264

HORIZONTAL AMPLIFIER

WAVEFORM AND VOLTAGE READINGS were obtained under the following conditions:

MAIN TIME BASE (B) —

TRIGGERING LEVEL	+45°; pushed in
TRIGGERING:	
MODE	TRIG
SLOPE	+
COUPLING	AC
SOURCE	EXT
TIME/CM1 mSEC/CM
VARIABLE (TIME/CM)	CALIBRATED
SWEEP MAGNIFIER	X1
HORIZONTAL POSITION (VERNIER) ..	ccw

INTENSITY

Normal

WAVEFORM CONDITIONS —

'B' TRIGGER INPUT Signal	10 Volts P-P Calibrator
AMPLITUDE CALIBRATOR	10 Volts
HORIZONTAL DISPLAY	B
SWEEP MAGNIFIER	X1
HORIZONTAL POSITION	Centered

QUIESCENT VOLTAGE CONDITIONS —

HORIZ INPUT Signal	None
HORIZONTAL DISPLAY	Ext X1
HORIZONTAL POSITION:	
Upper Voltage Readings	ccw
Lower Voltage Readings	cw

Also see IMPORTANT note on Block Diagram.

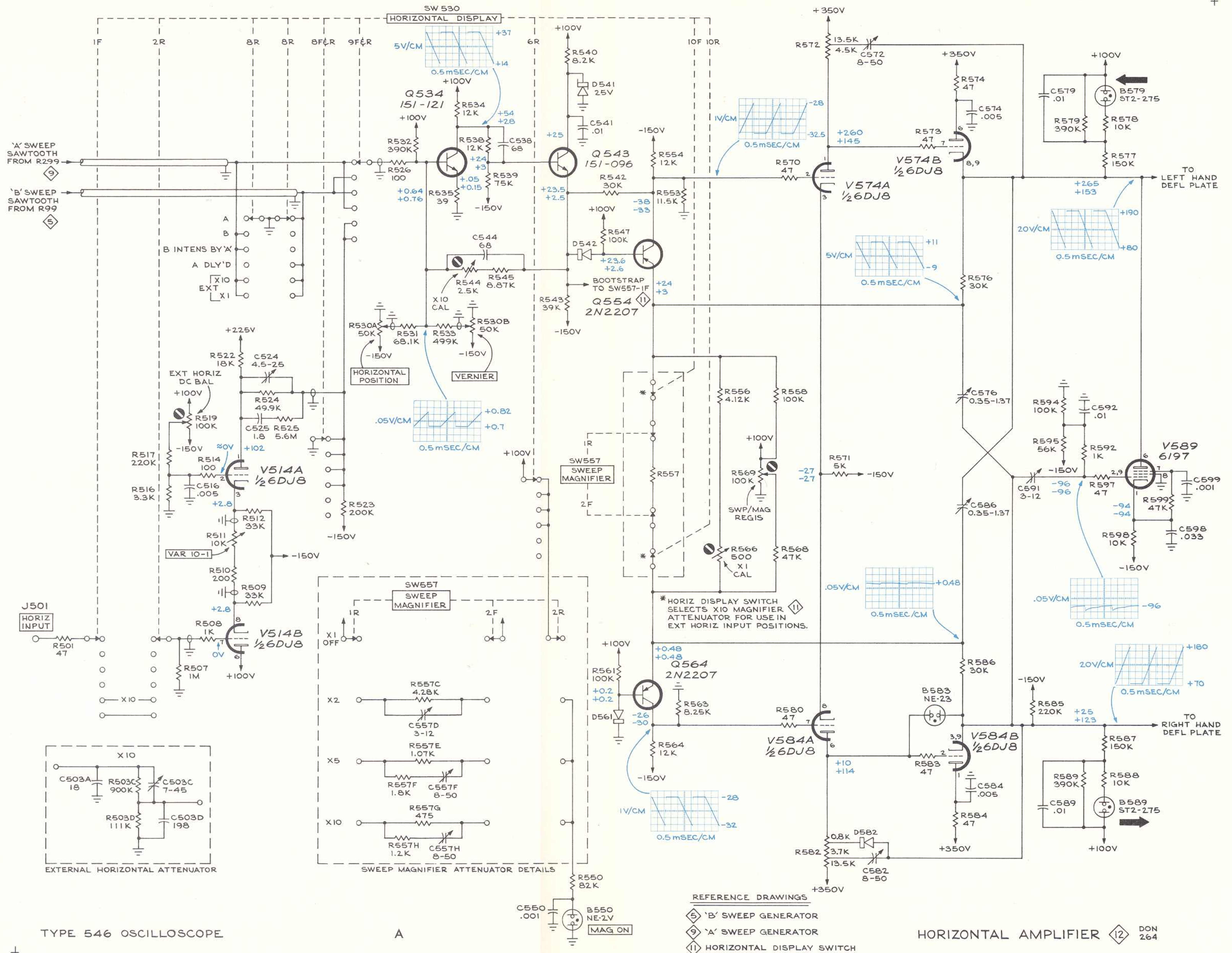

TYPE 546 OSCILLOSCOPE

A

REFERENCE DRAWINGS

- 5 'B' SWEEP GENERATOR
- 9 'A' SWEEP GENERATOR
- 11 HORIZONTAL DISPLAY SWITCH

HORIZONTAL AMPLIFIER 12 DON 264

SYNC AMP.

WAVEFORM AND VOLTAGE READINGS were obtained under the following conditions:

HORIZONTAL DISPLAY B

SINGLE SWEEP Switch NORMAL

MAIN TIME BASE (B) —

TRIGGER INPUT Signal	None
TRIGGERING LEVEL	cw
TRIGGERING SOURCE	EXT
TIME/CM	50 μ SEC
VARIABLE	CALIBRATED

POWER ON

WAVEFORM CONDITIONS —

'B' TRIGGERING MODE AUTO

QUIESCENT VOLTAGE CONDITIONS —

'B' TRIGGERING MODE TRIG

Also see IMPORTANT note on Block Diagram.

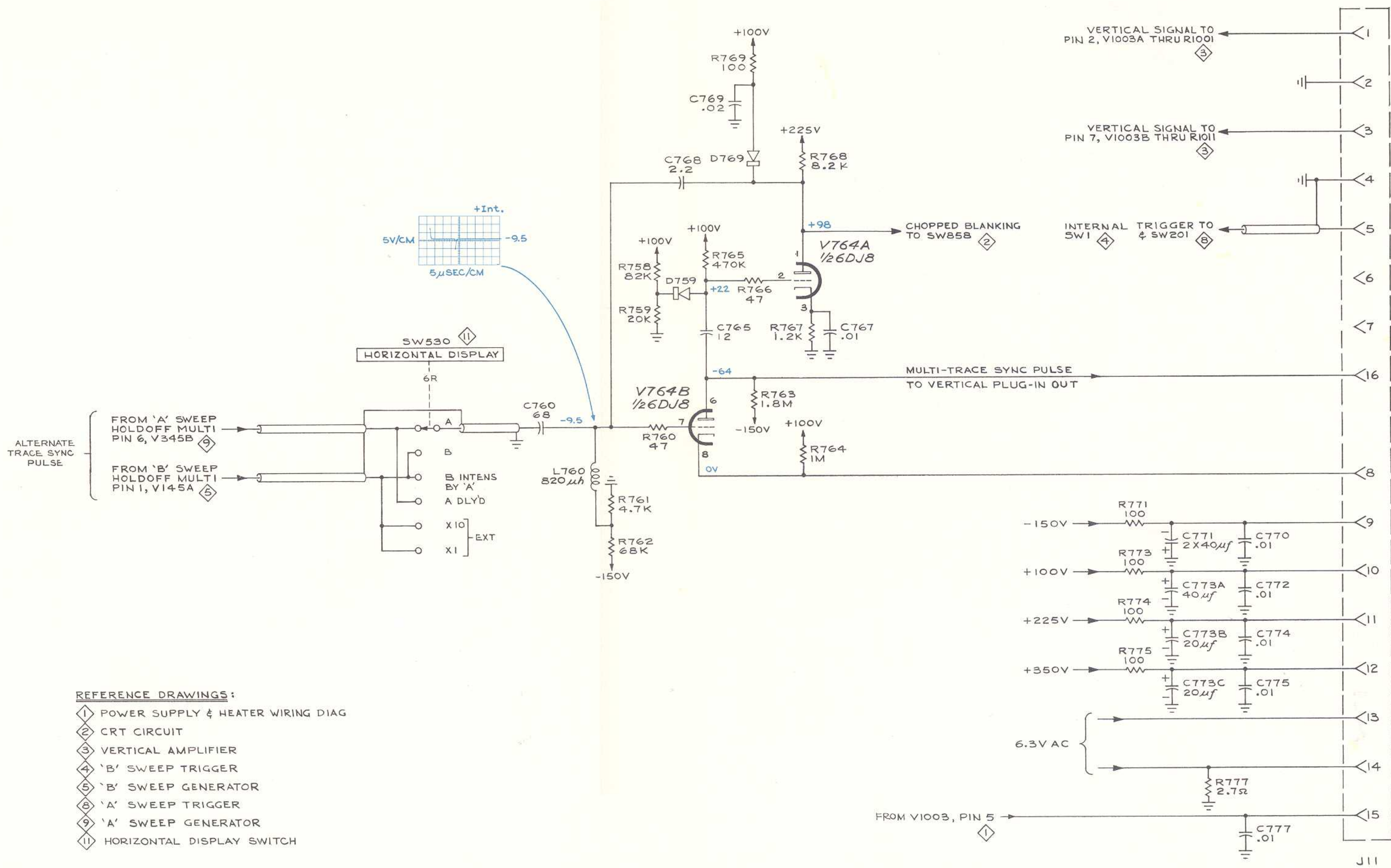

TYPE 546 OSCILLOSCOPE

A₁

MRH
664
PLUG-IN CONNECTOR ⑬

CALIBRATOR

WAVEFORM AND DYNAMIC VOLTAGE READINGS were obtained under the following conditions:

AMPLITUDE CALIBRATOR 10 Volts

POWER ON

Also see IMPORTANT note on Block Diagram.

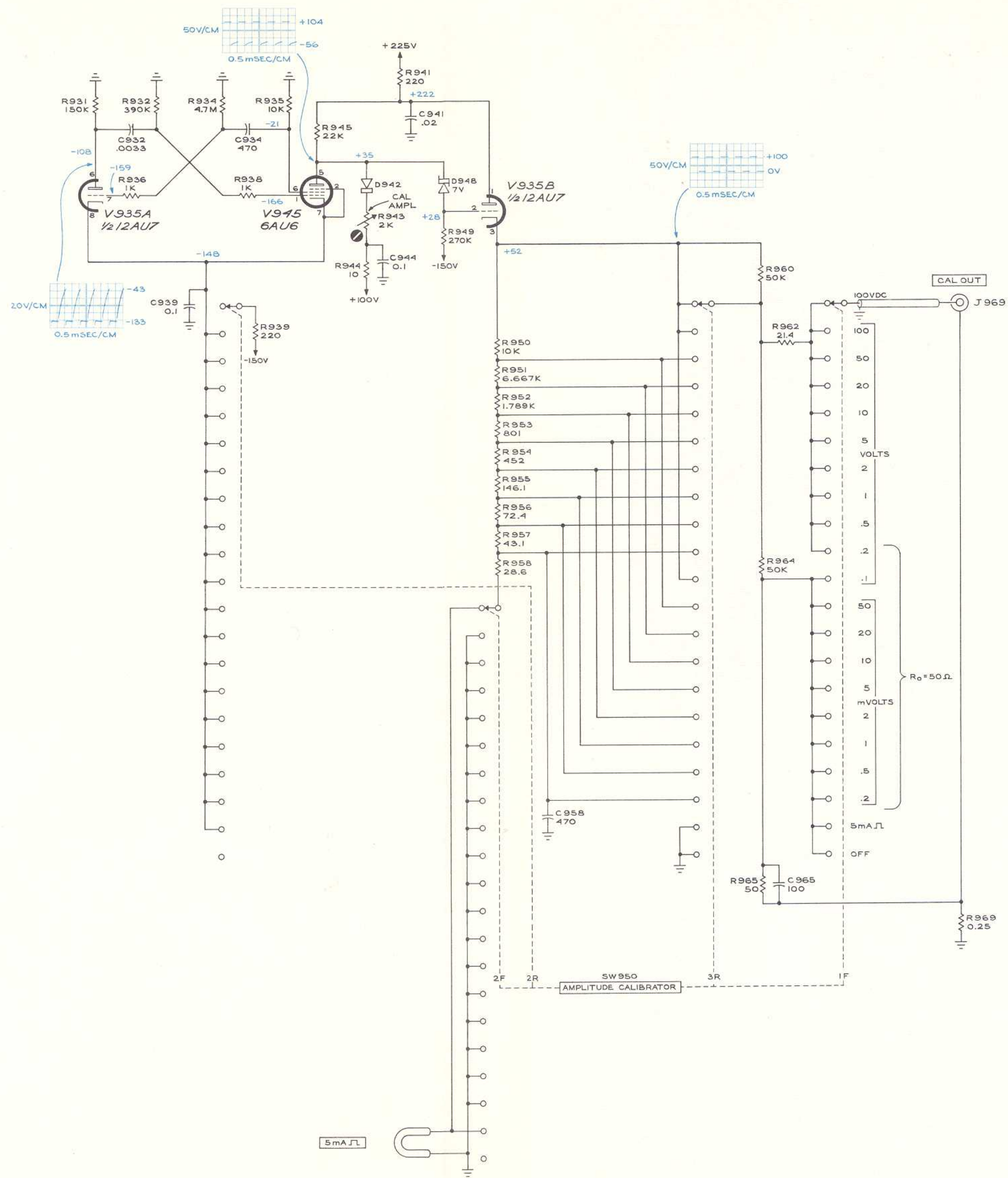

TYPE 546 OSCILLOSCOPE

CALIBRATOR
CMD 264

MANUAL CHANGE INFORMATION

At Tektronix, we continually strive to keep up with latest electronic developments by adding circuit and component improvements to our instruments as soon as they are developed and tested.

Sometimes, due to printing and shipping requirements, we can't get these changes immediately into printed manuals. Hence, your manual may contain new change information on following pages. If it does not, your manual is correct as printed.

TYPE 546

ADD: R581 and R591 to the Horizontal Amplifier schematic.

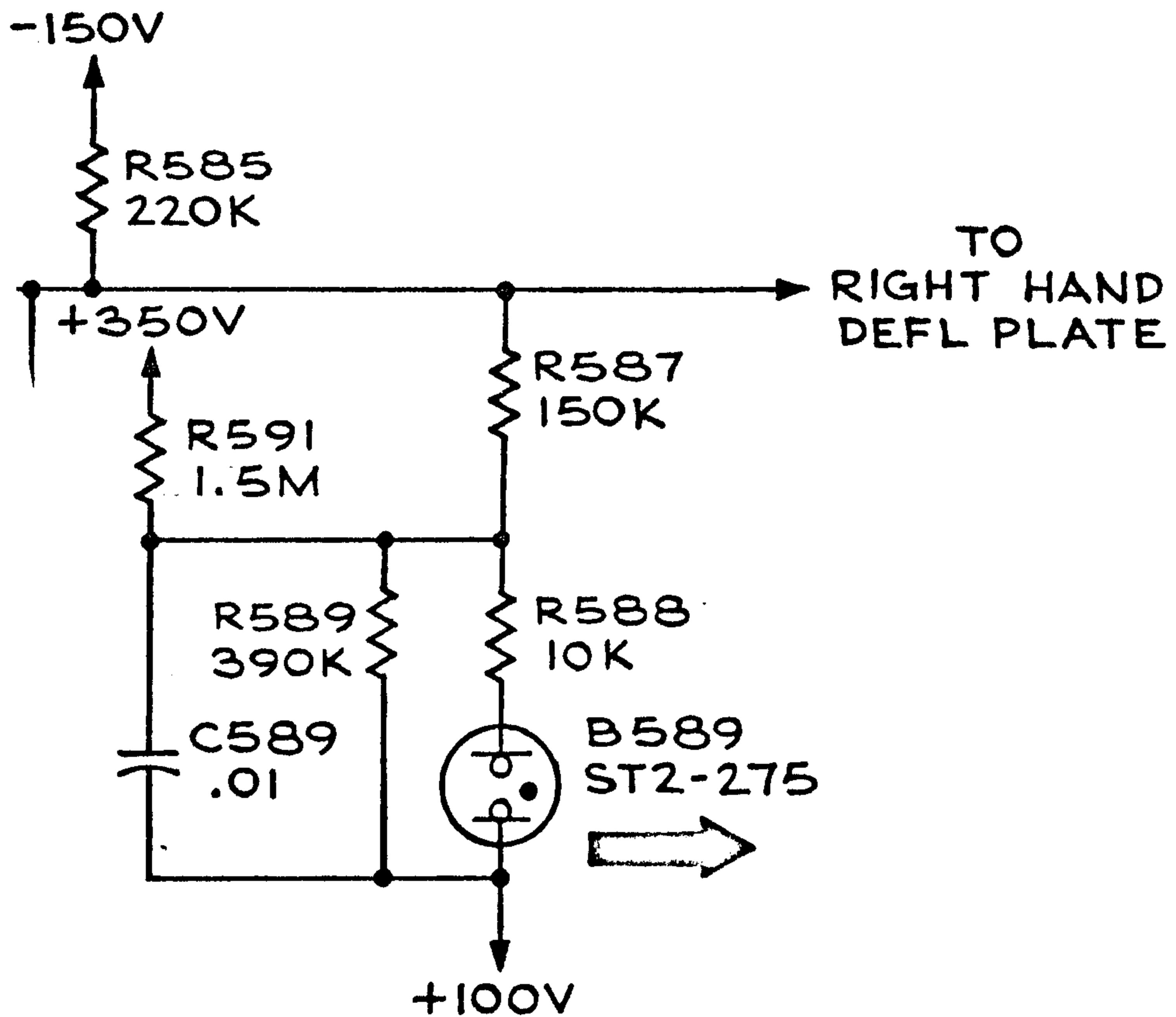
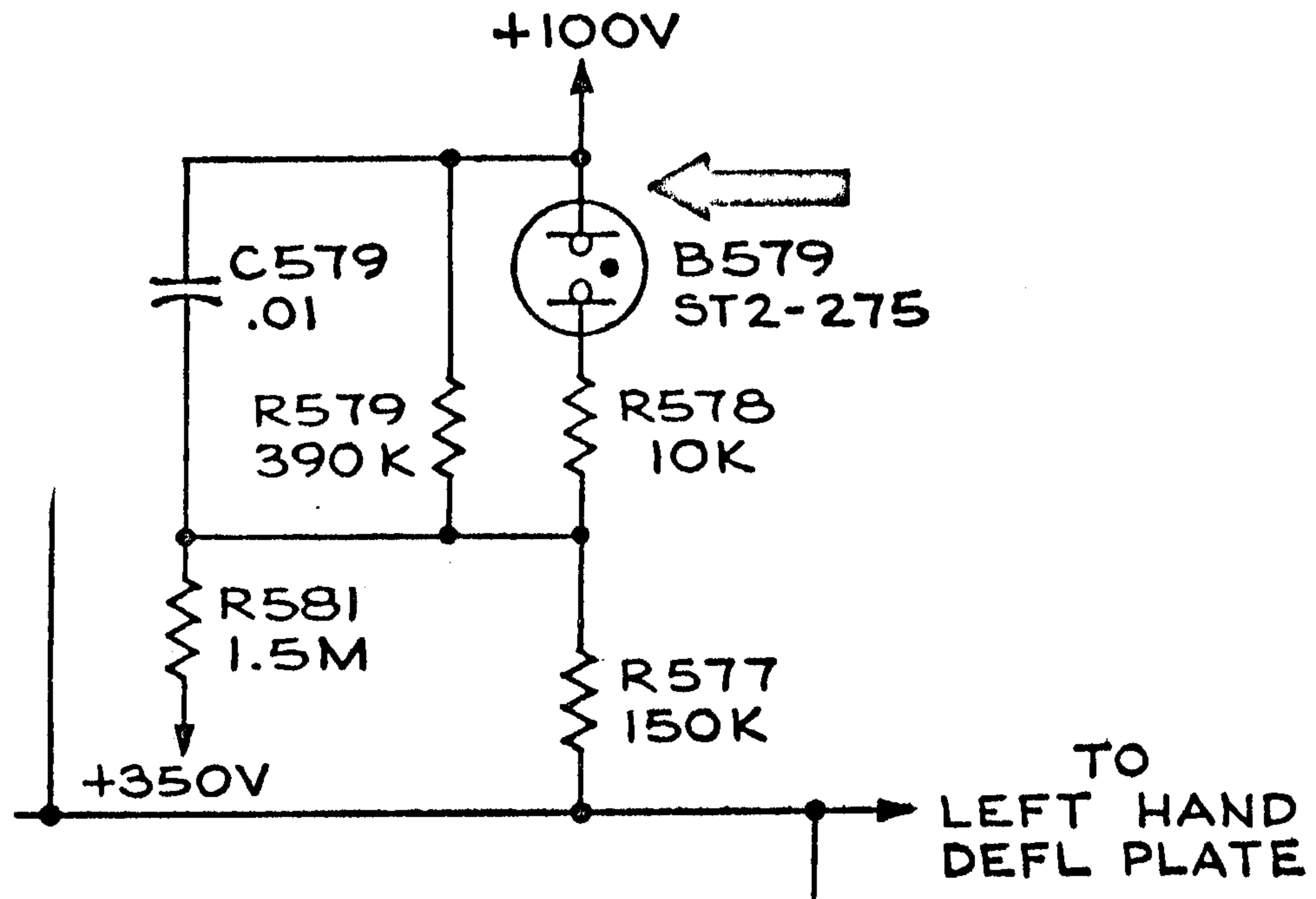

TYPE 546 -- TENT. S/N 450

PARTS LIST CORRECTION

CHANGE TO:

R511	311-491	10 k	Var	VAR 10-1
------	---------	------	-----	----------